

### 12HPB SERIES UNITS

The 12HPB is a residential split-system heat pump. The series is designed for use with expansion valves (TXV). All 12HPB units utilize scroll compressors.

Information contained in this manual is intended for use by qualified service technicians only. All specifications are subject to change.

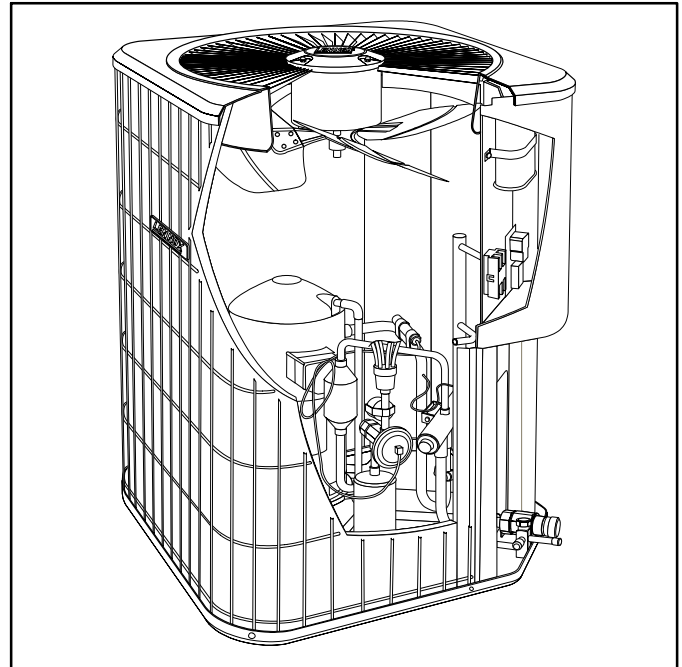
This manual is divided into sections which discuss the major components, refrigerant system, charging procedure, maintenance and operation sequence.

12HPB series units are available in 2, 2 -1/2, 3, 3 -1/2, 4 and 5 ton capacities. All major components (indoor blower and coil) must be matched according to Lennox recommendations for the compressor to be covered under warranty. Refer to the Engineering Handbook for approved system matchups.

#### ELECTROSTATIC DISCHARGE (ESD) Precautions and Procedures

### ⚠ CAUTION

Electrostatic discharge can affect electronic components. Take precautions during unit installation and service to protect the unit's electronic controls. Precautions will help to avoid control exposure to electrostatic discharge by putting the unit, the control and the technician at the same electrostatic potential. Neutralize electrostatic charge by touching hand and all tools on an unpainted unit surface before performing any service procedure.



### ⚠ WARNING

Refrigerant can be harmful if it is inhaled. Refrigerant must be used and recovered responsibly. Failure to follow this warning may result in personal injury or death.

### SPECIFICATIONS

Model No.		12HPB24	12HPB30	12HPB36	
Outdoor Coil	Net face area - sq. ft. (m <sup>2</sup> )	Outer coil	15.21 (1.41)	15.21 (1.41)	15.21 (1.41)
		Inner coil	5.44 (0.51)	14.50 (1.35)	14.50 (1.35)
	Tube diameter — in. (mm) & no. of rows		5/16 (8) — 1.37	5/16 (8) — 2	5/16 (8) — 2
	Fins per inch (m)		18 (709)	22 (866)	22 (866)
Outdoor Coil Fan	Diameter — in. (mm) & no. of blades		18 (457) — 3	18 (457) — 4	18 (457) — 4
	Motor hp (W)		1/6 (124)	1/6 (124)	1/6 (124)
	Cfm (L/s)		2500 (1180)	2450 (1155)	2450 (1155)
	Rpm		1100	1100	1100
	Watts		200	200	200
*Refrigerant charge furnished (HCFC-22)		6 lbs. 14 oz. (3.11 kg)	7 lbs. 14 oz. (3.56 kg)	8 lbs. 1 oz. (3.64 kg)	
Liquid line — in. (mm) o.d. connection (sweat)		3/8 (9.5)	3/8 (9.5)	3/8 (9.5)	
Vapor line — in. (mm) o.d. connection (sweat)		3/4 (19.1)	3/4 (19.1)	7/8 (22.2)	
Shipping weight — lbs. (kg) 1 package		162 (73)	181 (82)	187 (85)	

\*Refrigerant charge sufficient for 15 ft. (4.5 m) length of refrigerant lines.

### SPECIFICATIONS (continued)

Model No.		12HPB42	12HPB48	12HPB60	
Outdoor Coil	Net face area - sq. ft. (m <sup>2</sup> )	Outer coil	15.21 (1.41)	21.11 (1.96)	21.11 (1.96)
		Inner coil	14.50 (1.35)	20.31 (1.89)	20.31 (1.89)
	Tube diameter — in. (mm) & no. of rows		5/16 (8) — 2	5/16 (8) — 2	5/16 (8) — 2
	Fins per inch (m)		22 (866)	22 (866)	22 (866)
Outdoor Coil Fan	Diameter — in. (mm) & no. of blades		18 (457) — 4	22 (559) — 4	22 (559) — 4
	Motor hp (W)		1/3 (249)	1/3 (249)	1/3 (249)
	Cfm (L/s)		2930 (1385)	3890 (1835)	3890 (1835)
	Rpm		1100	1085	1085
	Watts		310	375	375
*Refrigerant charge furnished (HCFC-22)			8 lbs. 8 oz. (3.84 kg)	11 lbs. 12 oz. (5.32 kg)	12 lbs. 8 oz. (5.66 kg)
Liquid line — in. (mm) o.d. connection (sweat)			3/8 (9.5)	3/8 (9.5)	3/8 (9.5)
Vapor line — in. (mm) o.d. connection (sweat)			7/8 (22.2)	7/8 (22.2)	1-1/8 (28.6)
Shipping weight — lbs. (kg) 1 package			195 (88)	259 (117)	263 (119)

\*Refrigerant charge sufficient for 15 ft. (4.5 m) length of refrigerant lines.

### ELECTRICAL DATA

Model No.		12HPB24	12HPB30	12HPB36	12HPB42	12HPB48	12HPB60
Line voltage data — 60 hz		208/230v 1ph	208/230v 1ph	208/230v 1ph	208/230v 1ph	208/230v 1ph	208/230v 1ph
Compressor	Rated load amps	10.3	13.5	15.4	18.0	23.7	28.9
	Power factor	.96	.96	.96	.95	.96	.96
	Locked rotor amps	56.0	72.5	88.0	104.0	129.0	169.0
Outdoor Coil Fan Motor	Full load amps	1.1	1.1	1.1	1.9	1.9	1.9
	Locked rotor amps	1.9	1.9	1.9	4.1	4.1	4.1
Rec. maximum fuse or circuit breaker size (amps)		20	30	35	40	50	60
*Minimum circuit ampacity		14.0	18.0	20.4	24.4	31.5	38.0

\*Refer to National or Canadian Electrical Code manual to determine wire, fuse and disconnect size requirements.  
NOTE — Extremes of operating range are plus 10% and minus 5% of line voltage.

# I - UNIT COMPONENTS

Unit components are illustrated in figure 1.

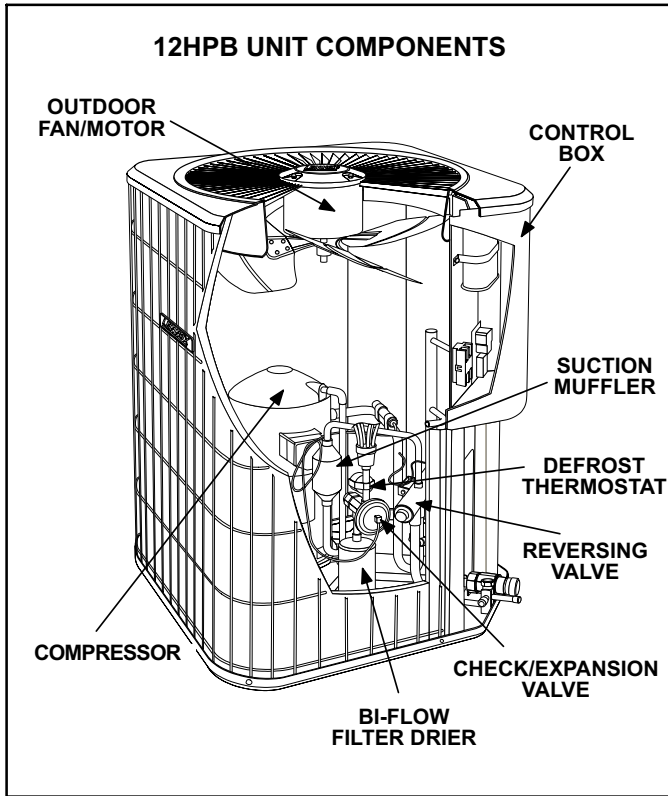


FIGURE 1

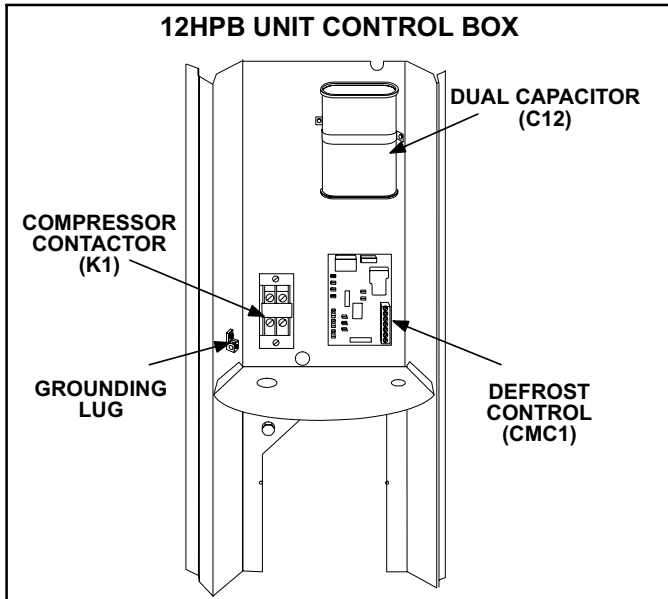


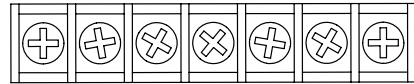
FIGURE 2

## A - Control Box (Figure 2)

12HPB units are not equipped with a 24V transformer. All 24 VAC controls are powered by the indoor unit. Refer to wiring diagram.

Electrical openings are provided under the control box cover. Field thermostat wiring is made to a 24V terminal strip located on the defrost control board located in the control box. See figure 3.

## 24V THERMOSTAT TERMINAL STRIP



T L C R W1 O Y1

"T" & "L" connections are used only if ambient thermistor and service light are installed in the 12HPB and the proper room thermostat is used. Only early model units will have this feature.

FIGURE 3

## 1 - Compressor Contactor K1

The compressor is energized by a contactor located in the control box. See figure 2. Single-pole and two-pole contactors are used in 12HPB series units. See wiring diagrams for specific unit. K1 is energized through the control board by the indoor thermostat terminal Y1 (24V) when thermostat demand is present.

## ⚠ DANGER

**Electric Shock Hazard.**  
May cause injury or death.



**Disconnect all remote electrical power supplies before opening unit panel. Unit may have multiple power supplies.**

**Some units are equipped with single-pole contactors. When unit is equipped with a single-pole contactor, line voltage is present at all components (even when unit is not in operation).**

## 2 - Dual Capacitor C12

The compressor and fan in 12HPB series units use permanent split capacitor motors. The capacitor is located inside the unit control box (see figure 2). A single "dual" capacitor (C12) is used for both the fan motor and the compressor (see unit wiring diagram). The fan side and the compressor side of the capacitor have different MFD ratings. See table 1 for dual capacitor ratings.

TABLE 1

12HPB (C12) DUAL CAPACITOR RATING			
Unit	Terminal	MFD	VAC
12HPB24	FAN	5	370
	HERM	40	
12HPB30	FAN	5	
	HERM	45	
12HPB36/42	FAN	5	
	HERM	50	
12HPB48	FAN	7.5	
	HERM	60	
12HPB60	FAN	7.5	
	HERM	80	

### 3 - Defrost System

#### 12HPB units built prior to April 2002

The 12HPB defrost system includes two components: a defrost thermostat, and a defrost control.

#### a - Defrost Thermostat

The defrost thermostat is mounted on the liquid line between the check/expansion valve and the distributor. When defrost thermostat senses 35°F (2°C) or cooler, its contacts close and send a signal to the defrost control board to start the defrost timing. It also terminates defrost when the liquid line warms up to 70°F (21°C).

#### b - Defrost Control

The defrost control board in the 12HPB series units has the combined functions of a time/temperature defrost control, defrost relay, time delay, diagnostic LEDs and field connection terminal strip.

The control provides automatic switching from normal heating operation to defrost mode and back. During compressor cycle (room thermostat demand cycle), if the "O" input is not on and the defrost thermostat is closed, the control accumulates compressor run times at 30, 60, or 90 minute field adjustable intervals. When the accumulated compressor run time ends, the defrost relays are energized and defrost begins.

#### Defrost Control Timing Pins

Each timing pin selection provides a different accumulated compressor run period during one thermostat run cycle. The defrost interval can be adjusted to 30, 60 or 90 minutes. See figure 4. The defrost period is a maximum of 14 minutes and cannot be adjusted. If no timing is selected, the control defaults to 90 minutes.

A TEST option is provided for troubleshooting. When the jumper is placed across the TEST pins, the timing of all functions is reduced by a factor of 128. For example, a 30 minute interval during TEST is 14 seconds and the 14 minute defrost is reduced to 6.5 seconds.

The TEST mode may be started at anytime. If the jumper is in the TEST position at power-up or for longer than five minutes, the control will ignore the TEST selection and will default to a 90 minute interval.

#### Time-Delay

12HPB model units built prior to August 1996 will feature a time off delay. The timed-off delay is five minutes long. Without the time delay it would be possible to short cycle the compressor. A scroll compressor, when short cycled, can run backward if head pressure is still high. It does not harm a scroll compressor to run backward, but it could cause a nuisance tripout of safety limits (internal overload). For this reason, if a TOC delay

should fail, it must be replaced. Do not bypass the control. Later model compressors have an arrest feature which eliminates the need for the TOC. This feature is internally built and mechanically prevents the compressor from turning backwards.

#### Pressure Switch Safety Circuit

The defrost control incorporates a pressure switch safety circuit that allows the application of up to two optional pressure switches; high pressure and/or loss of charge. See figure 4. During a demand cycle, the defrost control will lock out the unit on the third instance the unit goes off on any pressure switch wired to this circuit. The diagnostic LEDs will display a pattern for a lockout pressure switch on the third open pressure switch occurrence. See table 2. The unit will remain locked out until 24 volt power is broken to terminal "R" on the defrost board and then remade.

Remove factory-installed jumper before connecting optional pressure switches to control board. When two pressure switches are used, wire each switch to one set of terminals PS1 and PS2 on the defrost control board. See figure 4. When only one pressure switch is used, wire the switch to the two outside terminals of the pressure switch connections.

*NOTE: If not using a pressure switch, the factory-installed jumper wire must be connected, or unit will not operate.*

#### Ambient Thermistor & Service Light Connection

12HPB model units built prior to August 1996 will have a defrost control board which provides terminal connections for a monitoring kit (part number 76F53) which includes an ambient thermistor and a service light. The monitor kit provides a service light thermostat which activates the room thermostat service light during periods of inefficient operation. The thermistor compensates for changes in ambient temperatures which might cause excessive thermostat droop. Later 12HPB model units do not have the terminal connections; however the monitoring kit can still be used. See Installation Instructions for proper wiring.

#### Diagnostic LEDs

The defrost board uses two LEDs for diagnostics. The LEDs flash a specific sequence according to the condition.

TABLE 2

DEFROST CONTROL BOARD DIAGNOSTIC LED		
MODE	LED 1	LED 2
Normal Operation/ Power to board	Flash together with LED 2	Flash together with LED 1
Time Delay To Protect Compressor	Alternating Flashes with LED 2	Alternating Flashes with LED 1
Pressure Switch Open	Off	On
Pressure Switch Lockout	On	Off
Board Malfunction	On	On

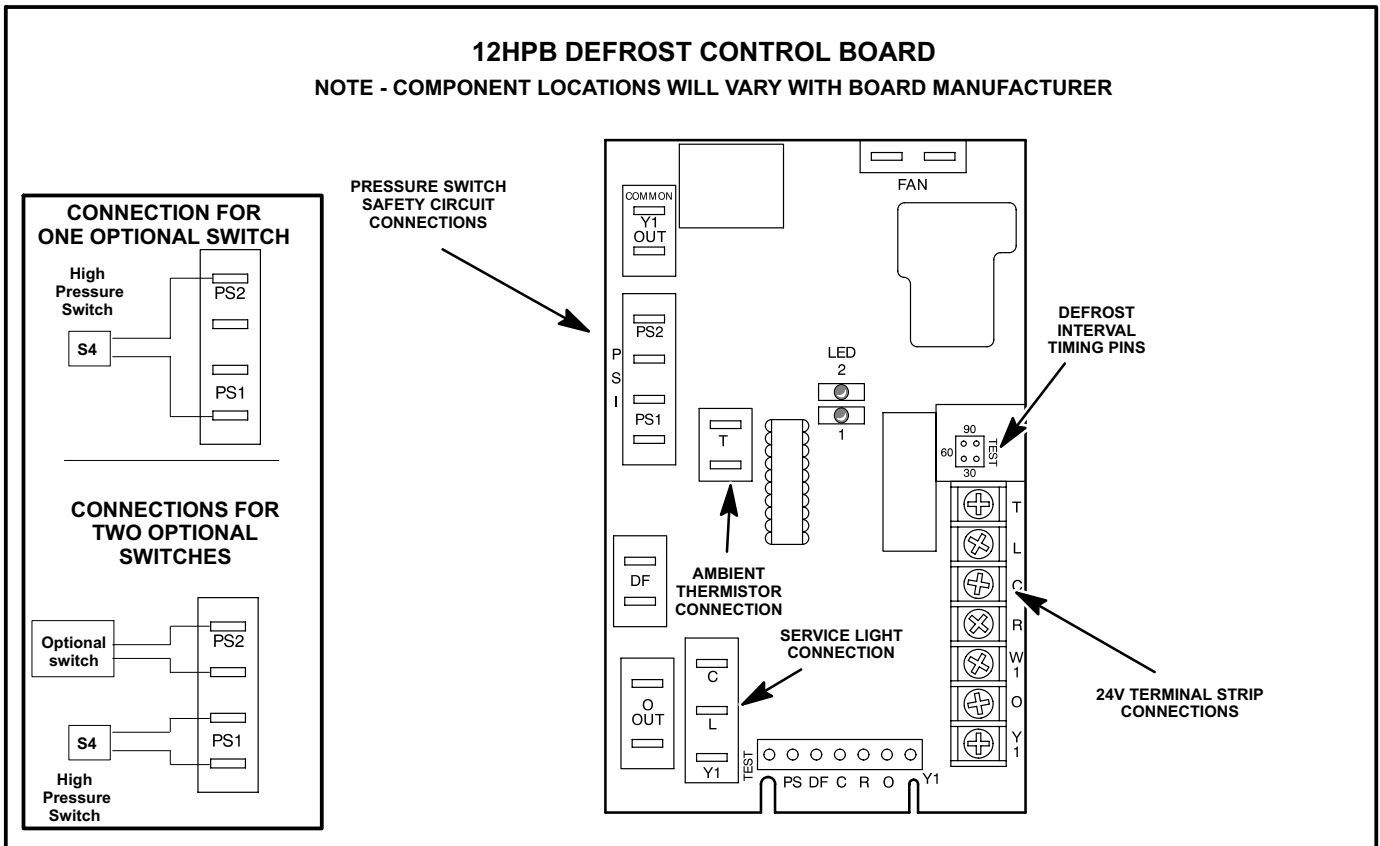


FIGURE 4

## 4 - Defrost System

12HPB units built April 2002 and later

The defrost system includes two components: a defrost thermostat and a defrost control.

### Defrost Thermostat

The defrost thermostat is located on the liquid line between the check/expansion valve and the distributor. When defrost thermostat senses 42°F (5.5°C) or cooler, the thermostat contacts close and send a signal to the defrost control board to start the defrost timing. It also terminates defrost when the liquid line warms up to 70°F (21°C).

### Defrost Control

The defrost control board includes the combined functions of a time/temperature defrost control, defrost relay, diagnostic LEDs and terminal strip for field wiring connections. See figure 5.

The control provides automatic switching from normal heating operation to defrost mode and back. During compressor cycle (call for defrost), the control accumulates compressor run times at 30, 60, or 90 minute field-adjustable intervals. If the defrost thermostat is closed when the selected compressor run time interval ends, the defrost relay is energized and defrost begins.

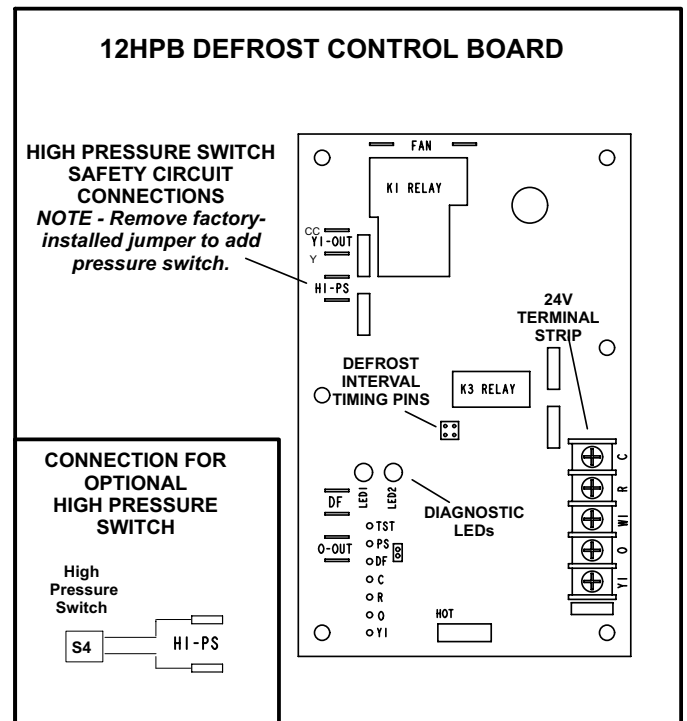


FIGURE 5

## Defrost Control Timing Pins

Each timing pin selection provides a different accumulated compressor run time period during one thermostat run cycle. This time period must occur before a defrost cycle is initiated. The defrost interval can be adjusted to 30 (T1), 60 (T2), or 90 (T3) minutes. See figure 5. The defrost timing jumper is factory-installed to provide a 60-minute defrost interval. If the timing selector jumper is not in place, the control defaults to a 90-minute defrost interval. The maximum defrost period is 14 minutes and cannot be adjusted.

A TEST option is provided for troubleshooting. **The TEST mode may be started any time the unit is in the heating mode and the defrost thermostat is closed or jumpered.** If the jumper is in the TEST position at power-up, the control will ignore the test pins. When the jumper is placed across the TEST pins for two seconds, the control will enter the defrost mode. If the jumper is removed before an additional 5-second period has elapsed (7 seconds total), the unit will remain in defrost mode until the defrost thermostat opens or 14 minutes have passed. If the jumper is not removed until after the additional 5-second period has elapsed, the defrost will terminate and the test option will not function again until the jumper is removed and re-applied.

## Pressure Switch Circuit

The defrost control incorporates a pressure switch circuit that allows the application of an optional high pressure switch. See figure 5. During a demand cycle, the defrost control will lock out the unit if the optional high pressure switch opens. The diagnostic LEDs will display a pattern for an open high pressure switch. See table 3. The unit will remain locked out until the switch resets or is reset.

Remove the factory-installed jumper before connecting the optional high pressure switch to the control board.

*NOTE - If not using a pressure switch, the factory-installed jumper wire must be connected.*

## Diagnostic LEDs

The defrost board uses two LEDs for diagnostics. The LEDs flash a specific sequence according to the condition.

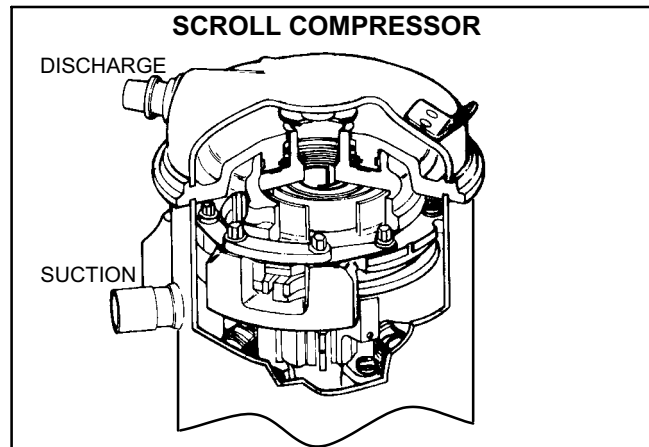
**TABLE 3**

DEFROST CONTROL BOARD DIAGNOSTIC LED		
MODE	LED 1	LED 2
Normal operation / power to board	Synchronized Flash with LED 2	Synchronized Flash with LED 1
Board failure or no power	Off	Off
Board failure	On	On
High pressure switch open	Flash	On
Low pressure switch open*	On	Flash
Pressure switch lockout*	On	Off
Anti-short-cycle / 5-minute delay*	Alternating Flash with LED 2	Alternating Flash with LED 1

## B - Compressor

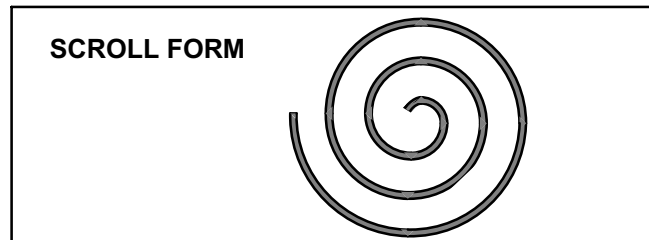
All 12HPB units utilize a scroll compressor. The scroll compressor design is simple, efficient and requires few moving parts. A cutaway diagram of the scroll compressor is shown in figure 6. The scrolls are located in the top of the compressor can and the motor is located just below. The oil level is immediately below the motor.

The scroll is a simple compression concept centered around the unique spiral shape of the scroll and its inherent properties. Figure 7 shows the basic scroll form. Two identical scrolls are mated together forming concentric spiral shapes (figure 8). One scroll remains stationary, while the other is allowed to "orbit" (figure 9). Note that the orbiting scroll does not rotate or turn but merely orbits the stationary scroll.

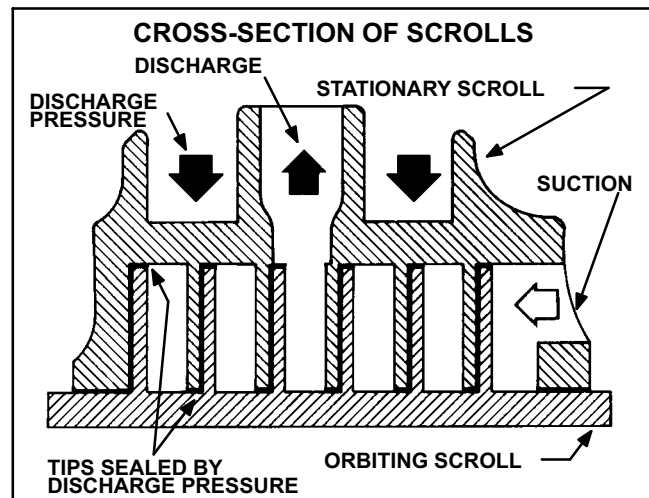


**FIGURE 6**

*NOTE - During operation, the head of a scroll compressor may be hot since it is in constant contact with discharge gas.*



**FIGURE 7**



**FIGURE 8**

The counterclockwise orbiting scroll draws gas into the outer crescent shaped gas pocket created by the two scrolls (figure 9 - 1). The centrifugal action of the orbiting scroll seals off the flanks of the scrolls (figure 9 - 2). As the orbiting motion continues, the gas is forced toward the center of the scroll and the gas pocket becomes compressed (figure 9 - 3). When the compressed gas reaches the center, it is discharged vertically into a chamber and discharge port in the top of the compressor (figure 8). The discharge pressure forcing down on the top scroll helps seal off the upper and lower edges (tips) of the scrolls (figure 8). During a single orbit, several pockets of gas are compressed simultaneously providing smooth continuous compression.

The scroll compressor is tolerant to the effects of liquid return. If liquid enters the scrolls, the orbiting scroll is allowed to separate from the stationary scroll. The liquid is worked toward the center of the scroll and is discharged. If the compressor is replaced, conventional Lennox cleanup practices must be used.

Due to its efficiency, the scroll compressor is capable of drawing a much deeper vacuum than reciprocating compressors. Deep vacuum operation can cause internal fuse arcing resulting in damaged internal parts and will result in compressor failure. Never use a scroll compressor for evacuating or "pumping-down" the system. This type of damage can be detected and will result in denial of warranty claims.

The scroll compressor is quieter than a reciprocating compressor, however, the two compressors have much different sound characteristics. The sounds made by a scroll compressor do not affect system reliability, performance, or indicate damage.

See compressor nameplate and ELECTRICAL DATA table on page 2 for compressor specifications.

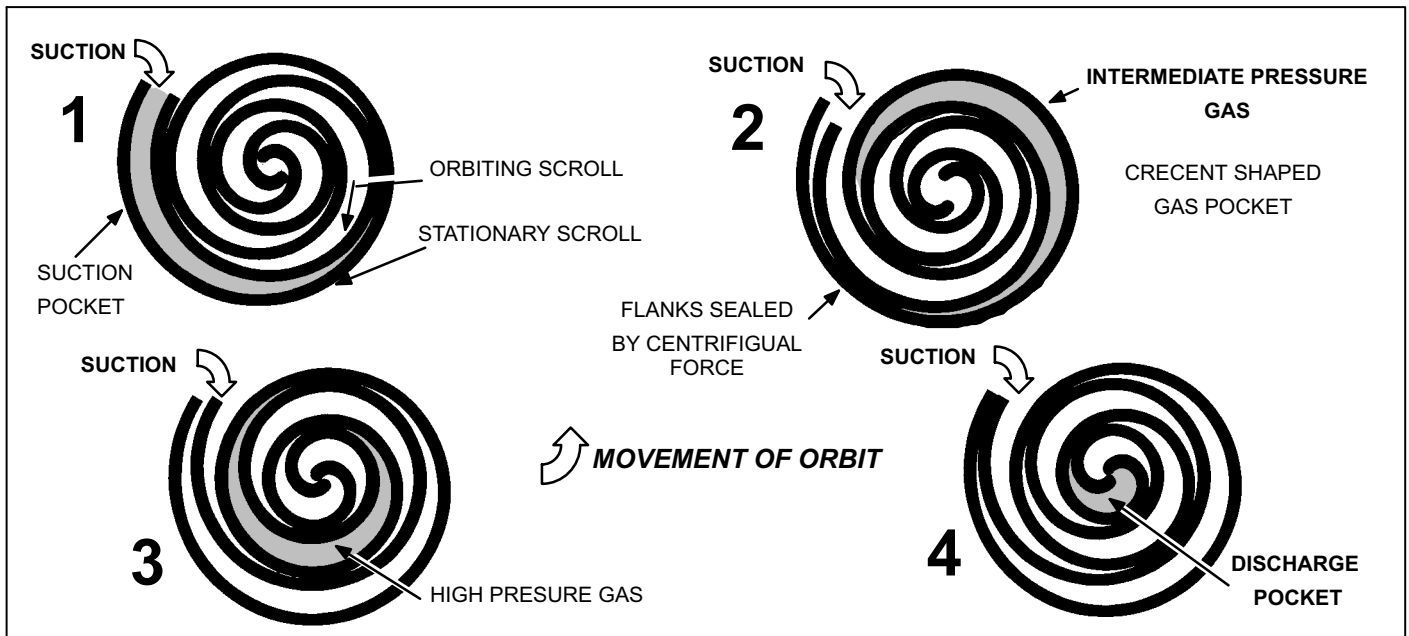
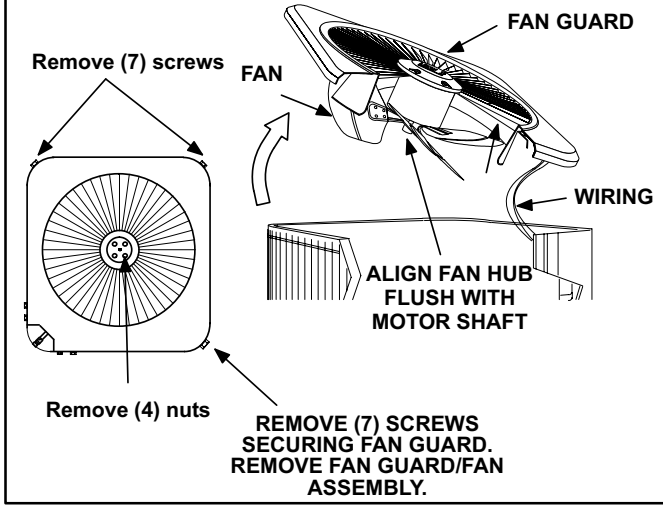


FIGURE 9

**CONDENSER FAN MOTOR AND COMPRESSOR ACCESS**



**FIGURE 10**

**⚠ DANGER**

Make sure all power is disconnected before beginning electrical service procedures.

**C - Outdoor Fan Motor**

All units use single-phase PSC fan motors which require a run capacitor. In all units, the condenser fan is controlled by the compressor contactor.

ELECTRICAL DATA tables in this manual show specifications for condenser fans used in 12HPBs.

Access to the condenser fan motor on all units is gained by removing the seven screws securing the fan assembly. See figure 10. The condenser fan motor is removed from the fan guard by removing the four nuts found on the top panel. If condenser fan motor must be replaced, align fan hub flush with motor shaft. Drip loops should be used in wiring when servicing motor.

**D - Reversing Valve L1 and Solenoid**

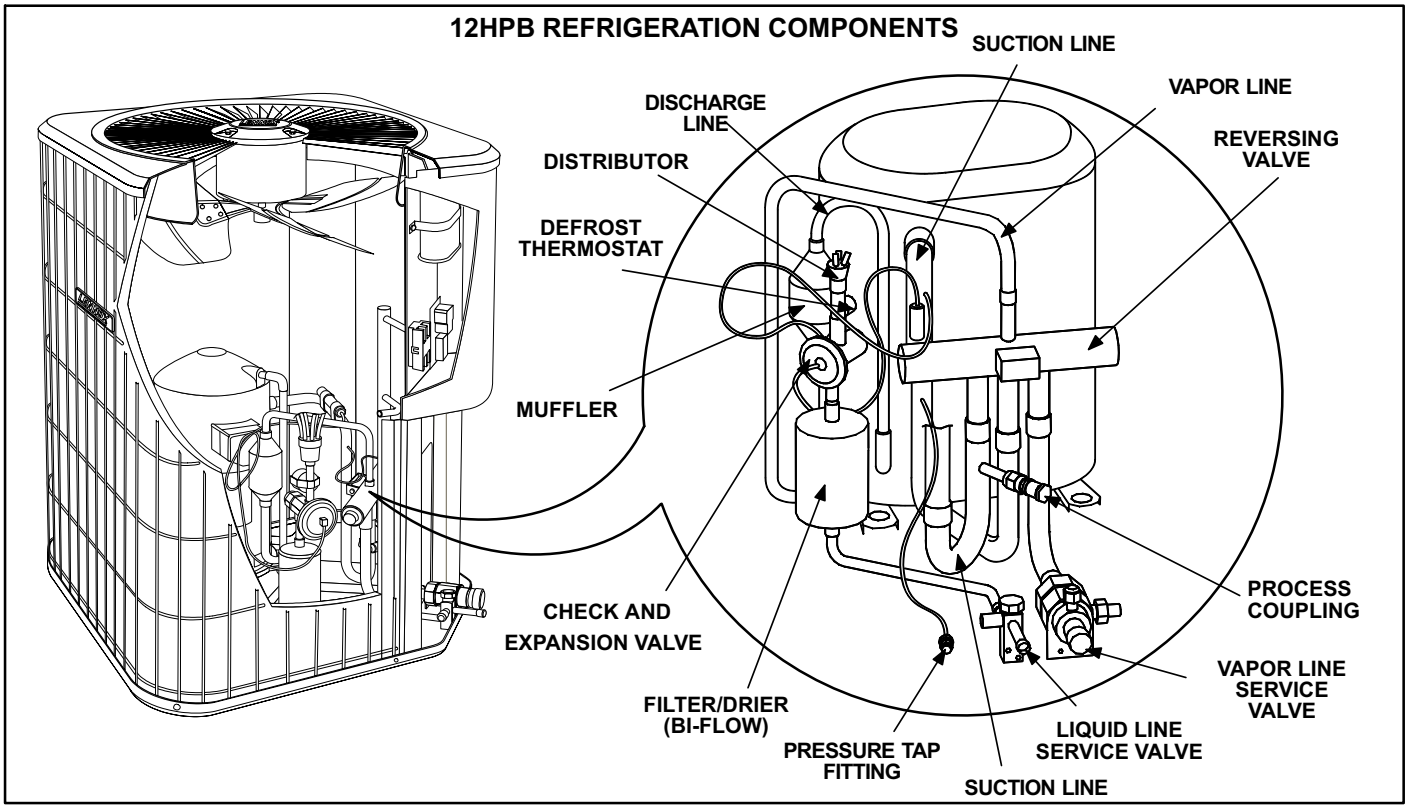
A refrigerant reversing valve with electromechanical solenoid is used to reverse refrigerant flow during unit operation. The reversing valve requires no maintenance. It is not repairable. If the reversing valve has failed, it must be replaced.

If replacement is necessary, access reversing valve by removing the outdoor fan motor. Refer to figure 10.

**II - REFRIGERANT SYSTEM**

See figure 11 for unit refrigerant components. Refer to figure 12 and 13 for refrigerant flow in the heating and cooling modes. The reversing valve is energized during cooling demand and during defrost.

**12HPB REFRIGERATION COMPONENTS**



**FIGURE 11**

### 12HPB COOLING CYCLE (SHOWING MANIFOLD GAUGE CONNECTIONS)

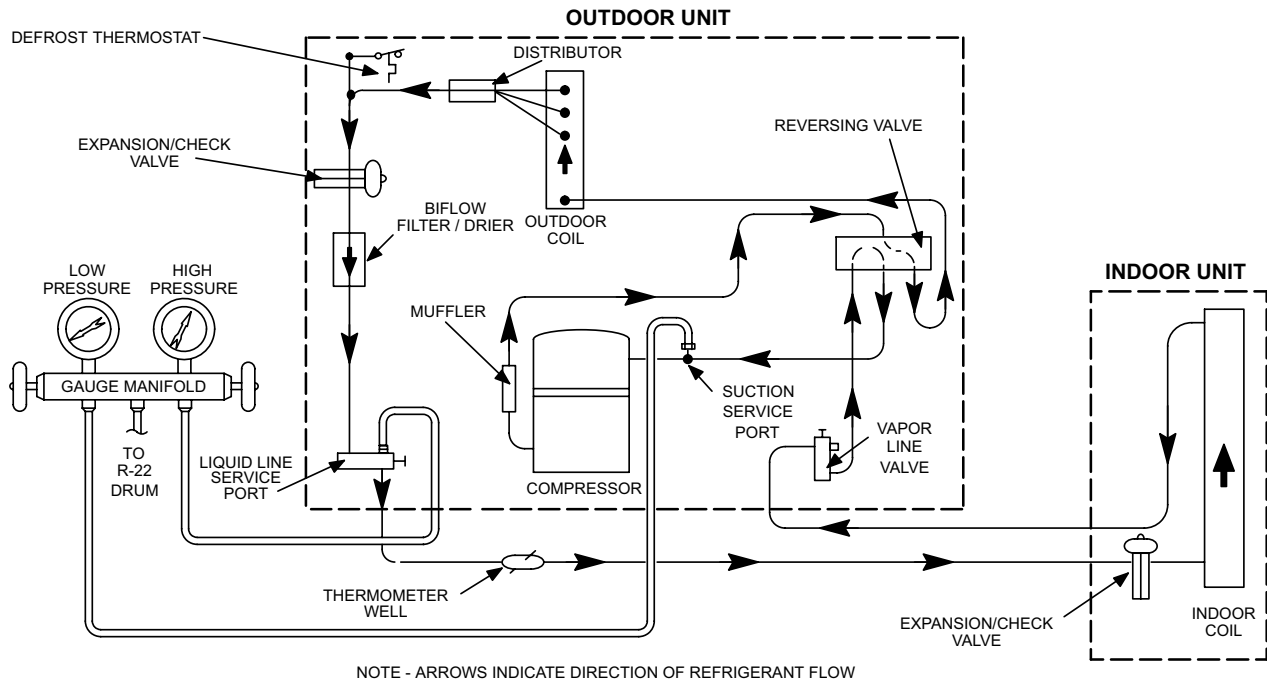


FIGURE 12

### 12HPB HEATING CYCLE (SHOWING MANIFOLD GAUGE CONNECTIONS)

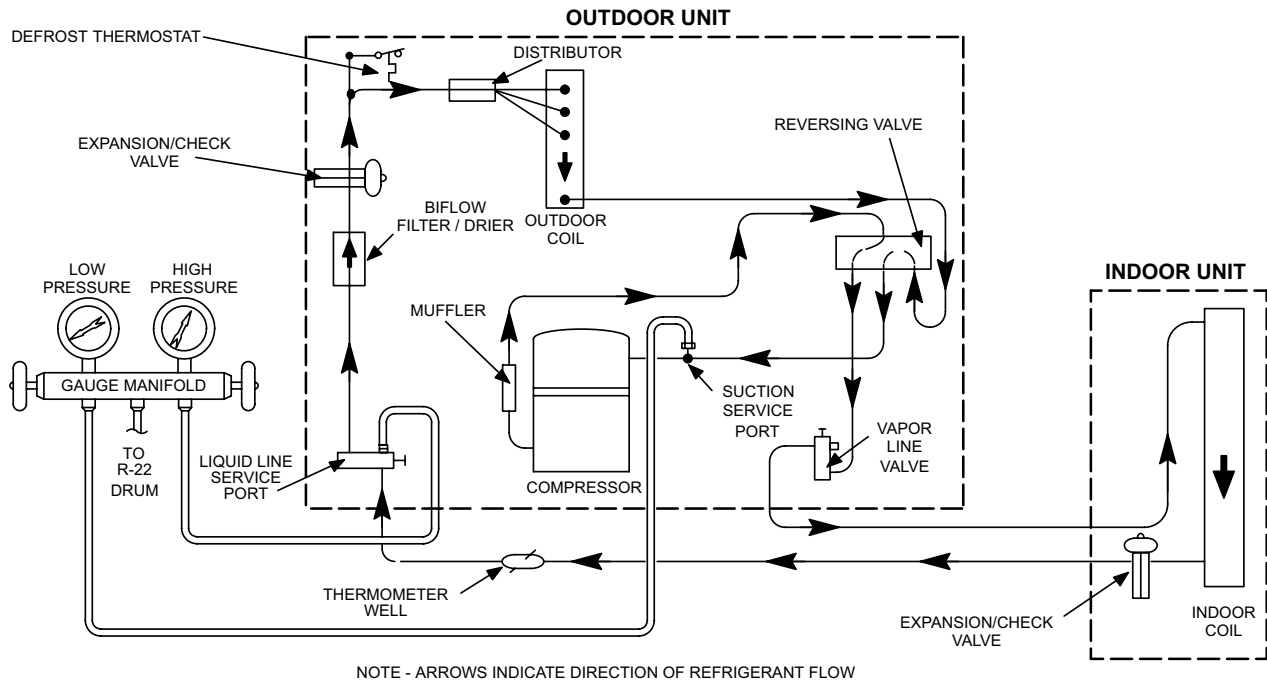


FIGURE 13

## A - Plumbing

Field refrigerant piping consists of liquid and vapor lines from the outdoor unit (sweat connections). Use Lennox L10 (flare) or L15 (sweat) series line sets as shown in table 4.

TABLE 4

Outdoor Unit Model No.	Line Set Model No. (L10 or L15)	Length of Lines		Liquid Line Outside Dia.		Vapor Line Outside Dia.	
		ft.	m	in.	mm	in.	mm
12HPB24 12HPB30	L10-41-20 L15-41-20	20	6	3/8	9.5	3/4	19
	L10-41-30 L15-41-30	30	9				
	L10-41-40 L15-41-40	40	12				
	L10-41-50 L15-41-50	50	15				
12HPB36 12HPB42 12HPB48	L10-65-30 L15-65-30	30	9	3/8	9.5	7/8	22.2
	L10-65-40 L15-65-40	40	12				
	L10-65-50 L15-65-50	50	15				
12HPB60	*Not available			3/8	9.5	1-1/8	28.5

\*Field fabricate.

## B - Service Valves

The liquid and vapor line service valves (figures 14 and 15) and gauge ports are accessible from outside the unit. Each valve is equipped with a service port. The service ports are used for leak testing, evacuating, charging and checking charge. A schrader valve is factory installed. A service port cap is supplied to protect the schrader valve from contamination and serve as the primary leak seal.

*NOTE-Always keep valve stem caps clean.*

### To Access Schrader Port:

- 1 - Remove service port cap with an adjustable wrench.
- 2 - Connect gauge to the service port.
- 3 - When testing is completed, replace service port cap. Tighten finger tight, then an additional 1/6 turn.

### To Open Liquid or Vapor Line Service Valve:

- 1 - Remove stem cap with an adjustable wrench.
- 2 - Using service wrench and hex head extension (5/16 for vapor line and 3/16 for liquid line), back the stem out counterclockwise until the valve stem just touches the retaining ring.
- 3 - Replace stem cap and tighten finger tight, then tighten an additional 1/6 turn.

## **⚠ DANGER**

**Do not attempt to backseat this valve. Attempts to backseat this valve will cause snap ring to explode from valve body under pressure of refrigerant. Personal injury and unit damage will result.**

### To Close Liquid or Vapor Line Service Valve:

- 1 - Remove stem cap with an adjustable wrench.
- 2 - Using service wrench and hex head extension (5/16 for vapor line and 3/16 for liquid line), turn stem clockwise to seat the valve. Tighten firmly.
- 3 - Replace stem cap. Tighten finger tight, then tighten an additional 1/6 turn.

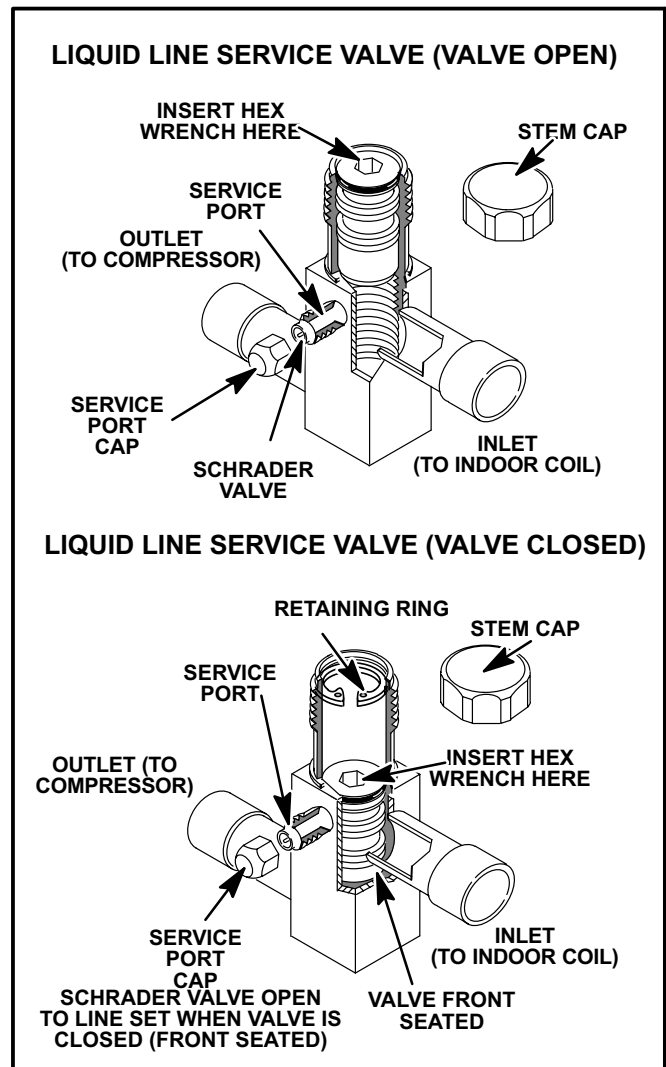


FIGURE 14

### Vapor Line (Ball Type) Service Valve

A ball-type full service valve is used on 12HPB. Valves are not rebuildable. If a valve has failed it must be replaced. A ball valve is illustrated in figure 15.

The ball valve is equipped with a service port. A schrader valve is factory installed. A service port cap is supplied to protect the schrader valve from contamination and assure a leak free seal.

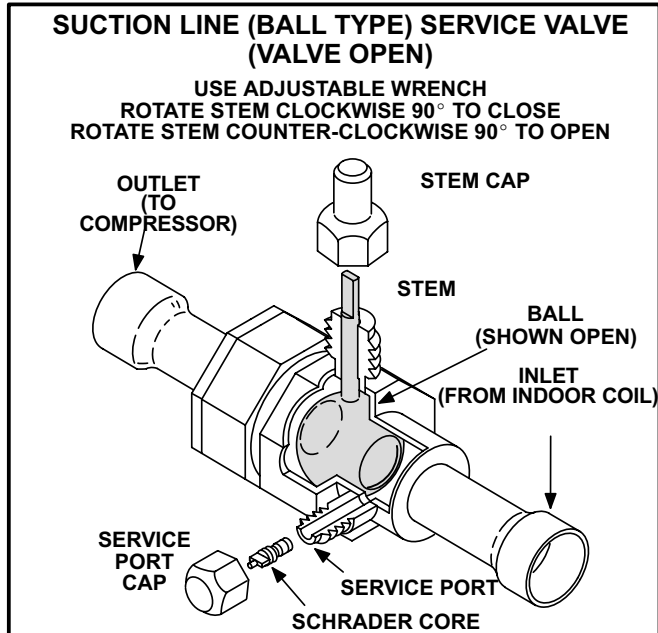


FIGURE 15

### III - CHARGING

The unit is factory-charged with the amount of R-22 refrigerant indicated on the unit rating plate. This charge is based on a matching indoor coil and outdoor coil with a 15 foot (4.5 m) line set. For varying lengths of line set, refer to table 5 for refrigerant charge adjustment. A blank space is provided on the unit rating plate to list actual field charge.

#### ! IMPORTANT

If line length is greater than 15 feet (4.5 m) add this amount. If line length is less than 15 feet (4.5 m), subtract this amount.

TABLE 5

LIQUID LINE SET DIAMETER	Ounce per 5 foot (ml per mm) adjust from 15 foot (4.5 m) line set*
1/4 in. (6 mm)	1 ounce per 5 feet (30 ml per 1524 mm)
5/16 in. (8mm)	2 ounce per 5 feet (60 ml per 1524 mm)
3/8 in. (10 mm)	3 ounce per 5 feet (90 ml per 1524 mm)

\*If line set is greater than 15 ft. (4.5 m) add this amount. If line set is less than 15 feet (4.5 m) subtract this amount

Units are designed for line sets up to 50 feet (15.2 m). Consult Lennox Refrigerant Piping Manual for line sets over 50 feet (15.2 m).

### A - Pumping Down System

#### ! CAUTION

Deep vacuum operation (operating compressor at 0 psig or lower) can cause internal fusite arcing resulting in a damaged or failed compressor. This type of damage will result in denial of warranty claim.

The system may be pumped down when leak checking the line set and indoor coil or making repairs to the line set or indoor coil.

- 1- Attach gauge manifold.
- 2- Front seat (close) liquid line valve.
- 3- Start outdoor unit.
- 4- Monitor suction gauge. Stop unit when 0 psig is reached.
- 5- Front seat (close) suction line valve.

### B - Leak Testing (To Be Done Before Evacuating)

- 1- Attach gauge manifold and connect a drum of dry nitrogen to center port of gauge manifold.
- 2- Open high pressure valve on gauge manifold and pressurize line set and indoor coil to 150 psig (1034 kPa).
- 3- Check lines and connections for leaks.

NOTE-The preferred method is to use an electronic leak or Halide detector. Add a small amount of R22 (3 to 5 psig [20kPa to 34kPa]) then pressurize with nitrogen to 150 psig.

- 4- Release nitrogen pressure from the system, correct any leaks and recheck.

#### ! DANGER

When using dry nitrogen, a pressure reducing regulator must be used to prevent excessive pressure in gauge manifold, connecting hoses, and within the system. Regulator setting must not exceed 150 psig (1034 kpa). Failure to use a regulator can cause equipment failure resulting in injury or death.

### C - Evacuating the System

- 1- Attach gauge manifold. Connect vacuum pump (with vacuum gauge) to center port of gauge manifold. With both manifold service valves open, start pump and evacuate indoor coil and refrigerant lines.

#### ! IMPORTANT

A temperature vacuum gauge, mercury vacuum (U-tube), or thermocouple gauge should be used. The usual Bourdon tube gauges are not accurate enough in the vacuum range.

## ⚠ IMPORTANT

**The compressor should never be used to evacuate a refrigeration or air conditioning system.**

- 2- Evacuate the system to 29 inches (737mm) vacuum. During the early stages of evacuation, it is desirable to stop the vacuum pump at least once to determine if there is a rapid loss of vacuum. A rapid loss of vacuum would indicate a leak in the system and a repeat of the leak testing section would be necessary.
- 3- After system has been evacuated to 29 inches (737mm), close gauge manifold valves to center port, stop vacuum pump and disconnect from gauge manifold. Attach an upright nitrogen drum to center port of gauge manifold and open drum valve slightly to purge line at manifold. Break vacuum in system with nitrogen pressure by opening manifold high pressure valve. Close manifold high pressure valve to center port.
- 4- Close nitrogen drum valve and disconnect from gauge manifold center port. Release nitrogen pressure from system.
- 5- Connect vacuum pump to gauge manifold center port. Evacuate system through manifold service valves until vacuum in system does not rise above .5mm of mercury absolute pressure or 500 microns within a 20-minute period after stopping vacuum pump.
- 6- After evacuation is complete, close manifold center port, and connect refrigerant drum. Pressurize system slightly with refrigerant to break vacuum.

### D - Charging

Charging must be done in the cooling mode. If the system is completely void of refrigerant, the recommended and most accurate method of charging is to weigh the refrigerant into the unit according to the total amount shown on the unit nameplate. Also refer to the SPECIFICATIONS tables on pages 1 and 2.

If weighing facilities are not available or if unit is just low on charge, the following procedure applies.

## ⚠ IMPORTANT

**The following procedures require accurate readings of ambient (outdoor) temperature, liquid temperature and liquid pressure for proper charging. Use a thermometer with accuracy of  $\pm 2^{\circ}\text{F}$  ( $\pm 1.1^{\circ}\text{C}$ ) and a pressure gauge with accuracy of  $\pm 5\text{PSIG}$  ( $\pm 34.5\text{kPa}$ ).**

For best results, indoor temperature should be between 70°F and 80°F (21°C and 27°C). If outdoor temperature is 60°F (16°C) or above the approach method of charging is used. If outdoor temperature is less than 60°F (16°C) the subcooling method of charging is used. Slight variations in charging temperature and pressure should be expected. Large variations may indicate a need for further servicing.

### APPROACH METHOD (TXV SYSTEMS) (Ambient Temperature of 60°F [16°C] or Above)

- 1 - Connect gauge manifold. Connect an upright R-22 drum to center port of gauge manifold.
  - 2 - Record outdoor air (ambient) temperature.
  - 3 - Operate indoor and outdoor units in cooling mode. Allow outdoor unit to run until system pressures stabilize.
  - 4 - Make sure thermometer well is filled with mineral oil before checking liquid line temperature.
  - 5 - Place thermometer in well and read liquid line temperature. Liquid line temperature should be warmer than the outdoor air temperature. Table 6 shows how many degrees warmer the liquid line temperature should be.
- Add refrigerant to lower liquid line temperature.  
Recover refrigerant to raise the liquid line temperature.  
Add refrigerant slowly as the unit approaches the correct temperature. This will allow refrigerant to stabilize allowing the correct temperature to be read.

<b>TABLE 6</b>	
<b>APPROACH METHOD</b>	
<b>AMBIENT TEMPERATURE OF 60 °F (16 °C) OR ABOVE</b>	
<b>Model</b>	<b>LIQUID LINE °F - OUTDOOR AMBIENT °F</b>
12HPB24	6°F (3.3°C)
12HPB30	11°F (6.1°C)
12HPB36	12°F (6.7°C)
12HPB42	10°F (5.6°C)
12HPB48	9°F (5.0°C)
12HPB60	8°F (4.4°C)

**TABLE 7**

Outdoor Coil Air Entering Temp. °F (°C)	12HPB24		12HPB30		12HPB36		12HPB42		12HPB48		12HPB60	
	liq. ±10 PSIG	vap. ±5 PSIG	liq. ±10 PSIG	vap. ±5 PSIG	liq. ±10 PSIG	vap. ±5 PSIG	liq. ±10 PSIG	vap. ±5 PSIG	liq. ±10 PSIG	vap. ±5 PSIG	liq. ±10 PSIG	vap. ±5 PSIG
65 (18.3)	144	78	140	76	152	74	152	75	146	75	146	73
75 (23.9)	170	79	164	77	178	76	179	76	171	77	175	74
85 (29.4)	199	80	194	78	208	77	210	77	198	78	206	75
95 (35)	228	81	224	79	238	78	241	78	229	79	237	76
105 (40.6)	261	82	259	80	275	81	278	79	268	81	275	77

NOTE - Typical pressures only. Indoor evaporator match up, indoor air quantity, and evaporator load will cause the pressures to vary.

**SUBCOOLING METHOD (TXV SYSTEMS)**  
**(Ambient Temperature Below 60°F [16°C])**

NOTE- It may be necessary to restrict air flow in order to reach liquid pressures in the 200-250 psig range which are required for checking charge. The indoor temperature should be above 70°F (21°C). Block equal sections of air intake panels, moving obstructions sideways until liquid pressures in the 200-250 psig range are reached.

- 1 - Connect gauge manifold. Connect an upright R-22 drum to center port of gauge manifold.
- 2 - Operate indoor and outdoor units in cooling mode. Allow outdoor unit to run until system pressures stabilize.
- 3 - Make sure thermometer well is filled with mineral oil before checking liquid line temperature.
- 4 - Read liquid line pressure and convert to condensing temperature using temperature/pressure conversion chart.  
 Condensing temperature (read from gauges) should be warmer than the liquid line temperature.
- 5 - Place thermometer in well and read liquid line temperature. Table 8 shows how much warmer the condensing temperature should be.  
 Add refrigerant to lower liquid line temperature.  
 Recover refrigerant to raise the liquid line temperature.
- 6 - When unit is properly charged liquid line pressures should approximate those given in table 7.

**TABLE 8**

SUBCOOLING METHOD AMBIENT TEMPERATURE BELOW 60 °F (16 °C)	
Model	Condensing Temp°F Warmer Than Liquid Line
12HPB24	11°F (6.1°C)
12HPB30	5°F (2.8°C)
12HPB36	3°F (1.7°C)
12HPB42	4°F (2.2°C)
12HPB48	4°F (2.2°C)
12HPB60	6°F (3.3°C)

**! IMPORTANT**

Use table 7 as a general guide for performing maintenance checks. Table 7 is not a procedure for charging the system. Minor variations in these pressures may be expected due to differences in installations. Significant deviations could mean that the system is not properly charged or that a problem exists with some component in the system. Used prudently, table 7 could serve as a useful service guide.

**E - Oil Charge**

See compressor nameplate.

**IV - MAINTENANCE**

At the beginning of each heating or cooling season, the system should be cleaned as follows:

**A - Outdoor Unit**

- 1 - Clean and inspect condenser coil. (Coil may be flushed with a water hose).

NOTE - Make sure all power is disconnected before flushing coil with water.

- 2 - Visually inspect all connecting lines, joints and coils for evidence of oil leaks.

NOTE-Outdoor fan motors are permanently lubricated.

**B - Indoor Coil**

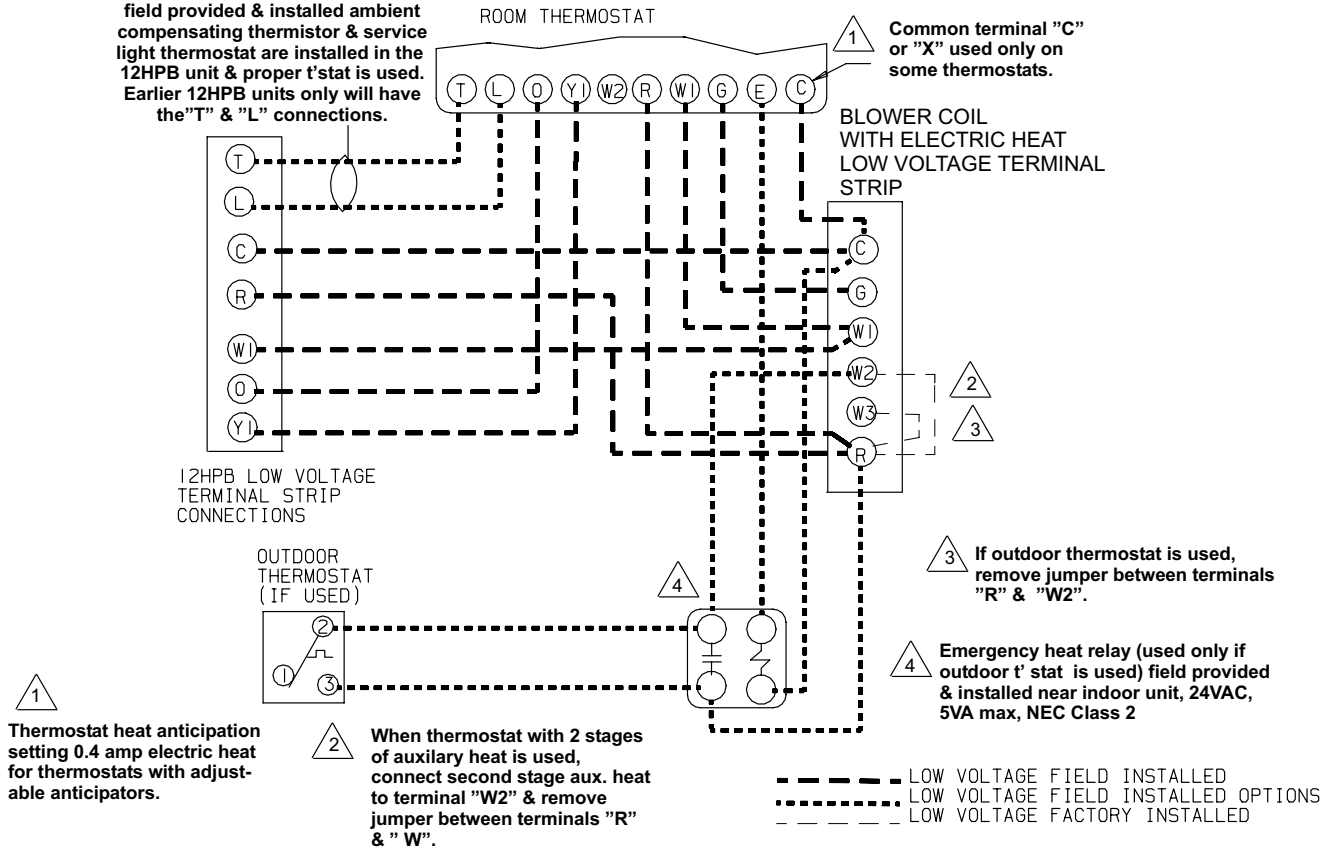
- 1 - Clean coil if necessary.
- 2 - Check connecting lines and coil for evidence of oil leaks.
- 3 - Check condensate line and clean if necessary.

**C - Indoor Unit**

- 1 - Clean or change filters.
- 2 - Bearings are pre-lubricated and need no further oiling.
- 3 - Check all wiring for loose connections.
- 4 - Check for correct voltage at unit.
- 5 - Check amp-draw on blower motor.

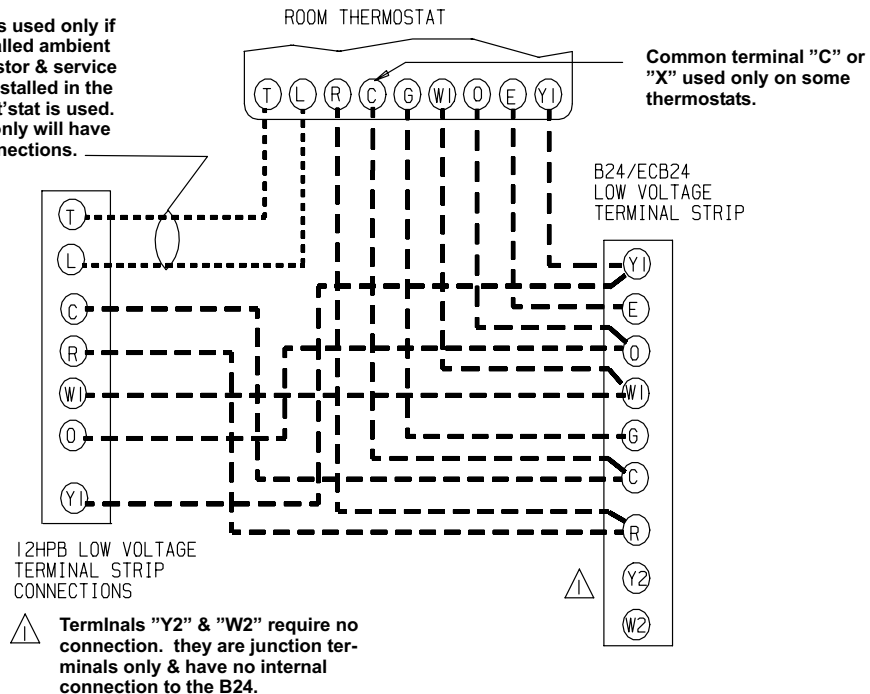
## LOW VOLTAGE FIELD WIRING FOR 12HPB SERIES UNITS WITH CB19/CBH19/ECB19, CB29M/ CB30M/ ECB29 COIL & TYPICAL ROOM THERMOSTAT

"T" & "L" connections used only if field provided & installed ambient compensating thermistor & service light thermostat are installed in the 12HPB unit & proper t'stat is used. Earlier 12HPB units only will have the "T" & "L" connections.



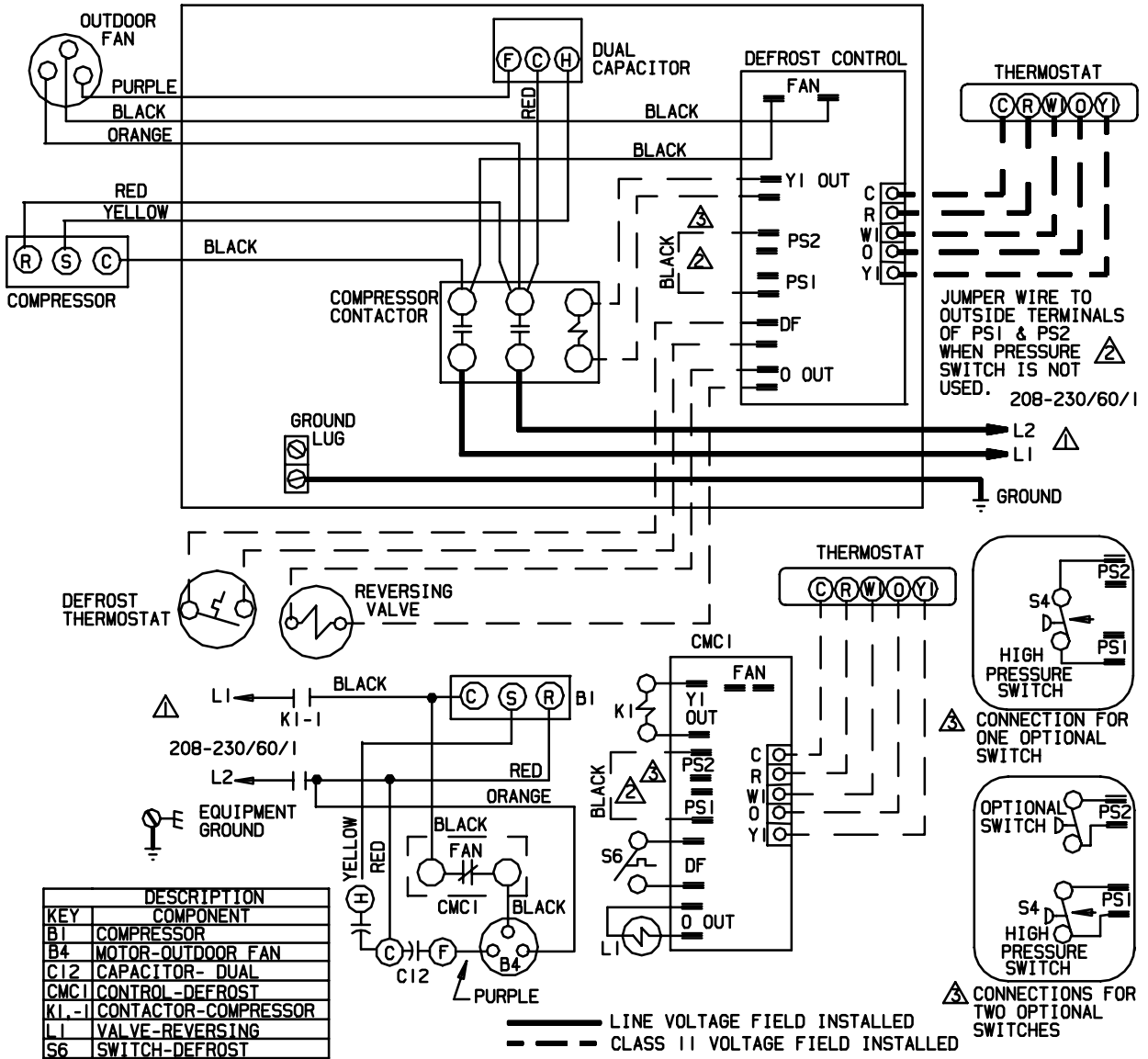
## LOW VOLTAGE FIELD WIRING FOR 12HPB SERIES UNITS WITH B24/ECB24 BLOWER COIL & TYPICAL ROOM THERMOSTAT

"T" & "L" connections used only if field provided & installed ambient compensating thermistor & service light thermostat are installed in the 12HPB unit & proper t'stat is used. Earlier 12HPB units only will have the "T" & "L" connections.

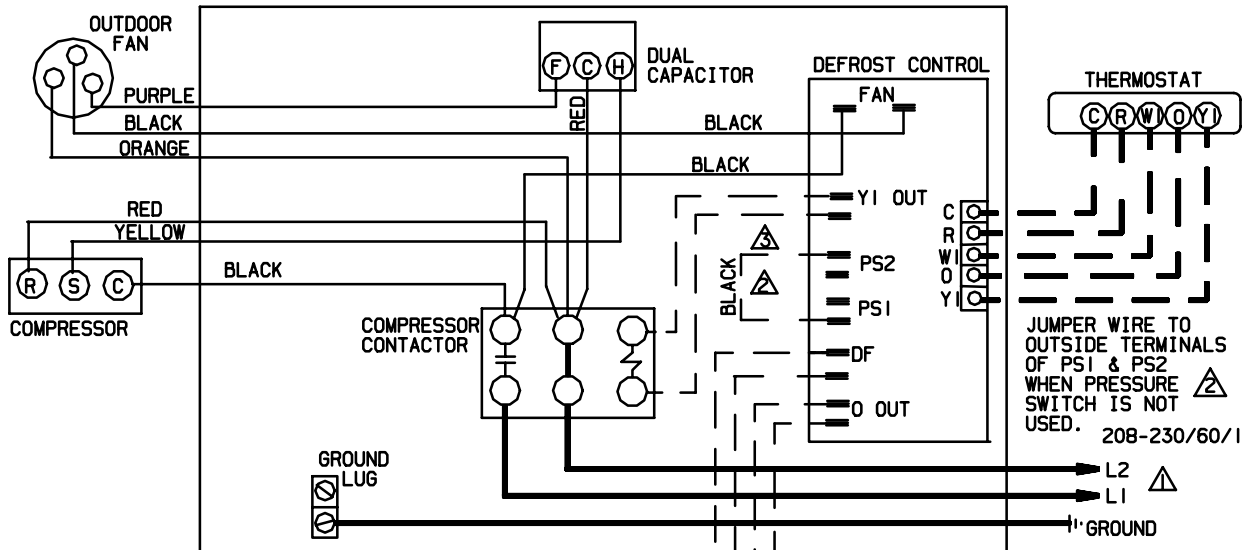


# V - WIRING DIAGRAM AND SEQUENCE OF OPERATION

## 12HPB 2 THROUGH 5 TON UNIT WIRING



# 12HPB 2 THROUGH 5 TON UNIT WIRING



L1  
208-230/60/1

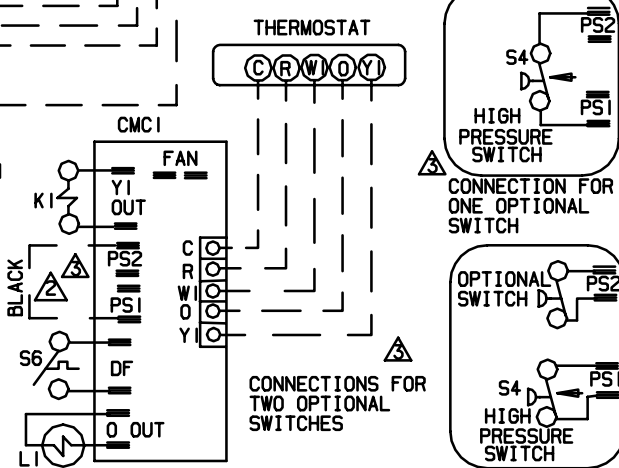
L2  
EQUIPMENT GROUND

KEY	DESCRIPTION
	COMPONENT
B1	COMPRESSOR
B4	MOTOR-OUTDOOR FAN
C12	CAPACITOR- DUAL
CMC1	CONTROL-DEFROST
K1-1	CONTACTOR-COMPRESSOR
L1	VALVE-REVERSING
S6	SWITCH-DEFROST

**WARNING-**  
ELECTRIC SHOCK HAZARD, CAN CAUSE INJURY OR DEATH. UNIT MUST BE GROUNDED IN ACCORDANCE WITH NATIONAL AND LOCAL CODES.

**NOTE-**  
FOR USE WITH COPPER CONDUCTORS ONLY. REFER TO UNIT RATING PLATE FOR MINIMUM CIRCUIT AMPACITY AND MAXIMUM OVER-CURRENT PROTECTION SIZE.

— LINE VOLTAGE FIELD INSTALLED  
- - - CLASS II VOLTAGE FIELD INSTALLED



## **LENNOX®** HEAT PUMP-OUTDOOR UNITS

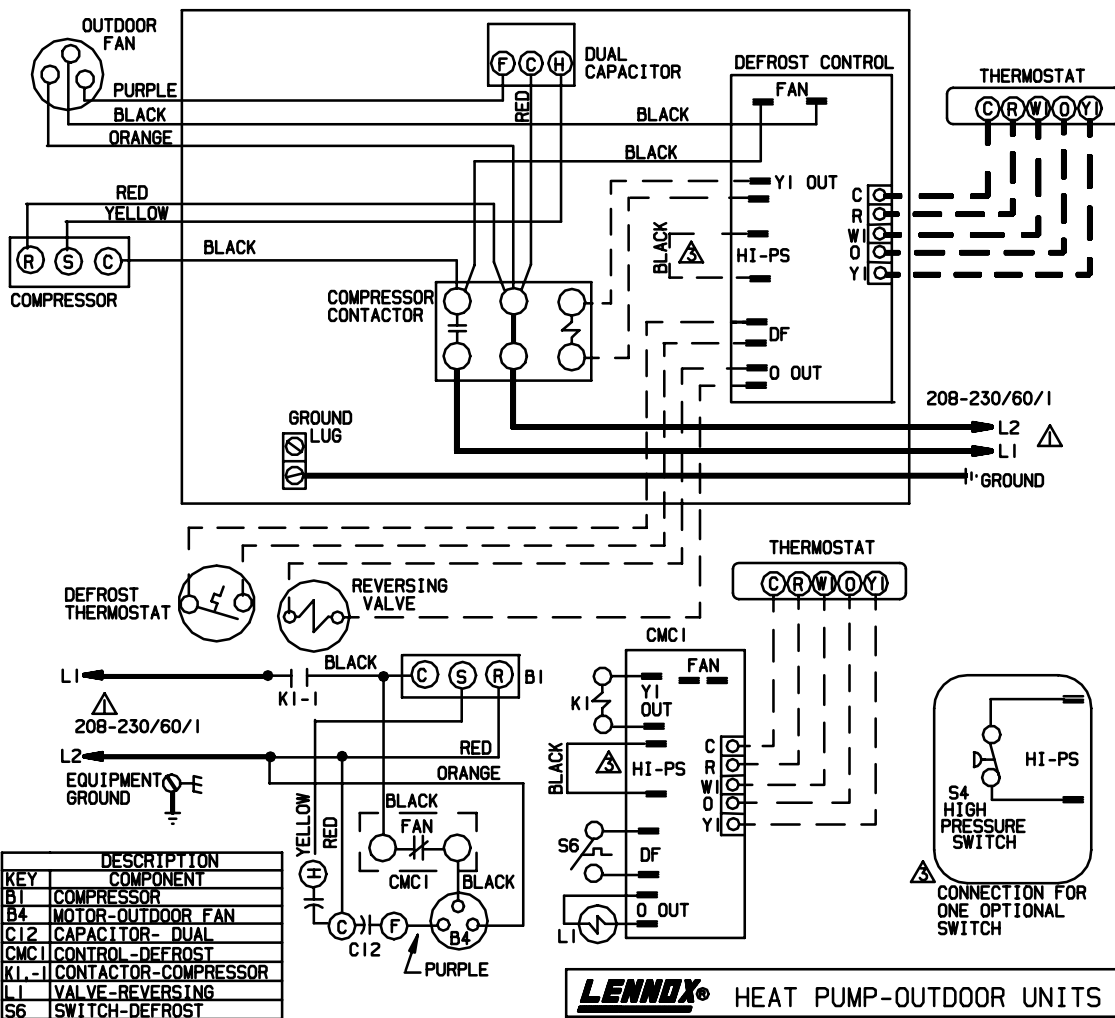
12HPB24-7, 8P	12HPB42-6, 7, 8, 9P
12HPB30-6, 7, 8, 9P	12HPB48-8, 9, 10, 11P
12HPB36-6, 7, 8, 9P	12HPB60-4, 5, 6, 7, 8, 9P

	Supersedes Form No.
1100	533, 475W
	New Form No.
	533, 652W

©2000 Lennox Industries Inc.

Litho U.S.A.

# 12HPB 2 THROUGH 5 TON UNIT WIRING



**LENNOX® HEAT PUMP-OUTDOOR UNITS**

12HPB24-9P	12HPB42-10P, 11P
12HPB30-10P, 11P	12HPB48-12P, 13P
12HPB36-10P, 11P	12HPB60-10P, 11P

1201	Supersedes Form No. 533,652W
	New Form No. 533,928W

©2001 Lennox Industries Inc. Litho U.S.A.

## 12HPB 1-1/2 THROUGH 5 TON OPERATING SEQUENCE

This is the sequence of operation for 12HPB series units. The sequence is outlined by numbered steps which correspond to circled numbers on the adjacent diagram.

*NOTE- The thermostat used may be electromechanical or electronic.*

*NOTE- Transformer in indoor unit supplies power (24 VAC) to the thermostat and outdoor unit controls.*

### COOLING:

- 1 - Internal thermostat wiring energizes terminal O by cooling mode selection, energizing the reversing valve L1. Cooling demand initiates at Y1 in the thermostat.
- 2 - 24VAC energizes compressor contactor K1.
- 3 - K1-1 N.O. closes, energizing compressor (B1) and outdoor fan motor (B4).
- 4 - Compressor (B1) and outdoor fan motor (B4) begin immediate operation.

### END OF COOLING DEMAND:

- 5 - Cooling demand is satisfied. Terminal Y1 is de-energized.
- 6 - Compressor contactor K1 is de-energized.
- 7 - K1-1 opens and compressor (B1) and outdoor fan motor (B4) are de-energized and stop immediately.
- 8 - Terminal O is de-energized when internal thermostat is out of cooling mode, de-energizing the reversing valve L1.

### FIRST STAGE HEAT:

- 9 - Heating demand initiates at Y1.
- 10 - 24VAC energizes compressor contactor K1.
- 11 - K1-1 N.O. closes, energizing compressor and outdoor fan motor.
- 12 - Compressor (B1) and outdoor fan motor (B4) begin immediate operation.

### END OF FIRST STAGE HEAT:

- 13 - Heating demand is satisfied. Terminal Y1 is de-energized.
- 14 - Compressor contactor K1 is de-energized.
- 15 - K1-1 opens and compressor (B1) and outdoor fan motor (B4) are de-energized and stop immediately.

### DEFROST MODE:

- 16 - During heating operation when outdoor coil temperature drops below 35°F (2°C) or 42°F (5.5°C) see defrost system description for specific unit dash number defrost switch (thermostat) S6 closes.
- 17 - Defrost control CMC1 begins timing. If defrost thermostat (S6) remains closed at the end of the 30,60 or 90 minute period, defrost relay energizes and defrost begins.
- 18 - During defrost CMC1 energizes the reversing valve and W1 on the terminal strip (operating indoor unit on the first stage heat mode), while de-energizing outdoor fan motor B4.
- 19 - Defrost continues 14 ± 1 minutes or until thermostat switch (S6) opens. When defrost thermostat opens, defrost control timer loses power and resets.
- 20 - When CMC1 resets, the reversing valve and W1 on the terminal strip are de-energized, while the outdoor fan motor B4 is energized.
- 21 - When CMC1 resets, the reversing valve and W1 on the terminal strip are de-energized, while the outdoor fan motor B4 is energized.