

GCS/CHA16 SERIES UNITS

GCS16 series units in the 6, 7.5, 10 and 12.5 ton (21, 26.4, 35.2 and 44.0 kW) cooling size are packaged combination gas heat / dx cool units designed for commercial applications. Gas heat sections are available with Lennox' new tubular heat exchanger in 160,000 200,000 and 270,000 (46.9, 58.6 and 79.1 kW) Btuh input sizes. Optional electric heat sections with inputs of 10 to 50kW, are available in the CHA16 series units and install inside the cabinet.

All GCS/CHA16 model units utilize a scroll compressor. The GCS/CHA16-072 has one compressor and the GCS/CHA16-090,-120 and -150 has two. The scroll compressor offers high volumetric efficiency, quiet operation and the ability to start under system load. Continuous flank contact, maintained by centrifugal force, minimizes gas leakage and maximizes efficiency. The motor is internally protected from excessive current and temperature.

All GCS/CHA16 models are designed for horizontal or down flow discharge application and may be fitted with RMF16 mounting frame, REMD16 economizer and RTD11 ceiling diffuser.

All GCS/CHA16 models are designed to accept several different thermostat control systems such as the Honeywell T7300 or Honeywell T8621D with minimum field wiring. Control options such as economizer and warm up kit, connect to the unit with jack-plugs. When plugged in the controls become an integral part of the unit wiring. Units are also equipped with low voltage pigtails to facilitate thermostat field wiring.

Information in this manual is for use by a qualified service technician only. All specifications in this manual are subject to change. Procedures outlined in this manual are represented as a recommendation only and do not supersede or replace state or local codes.

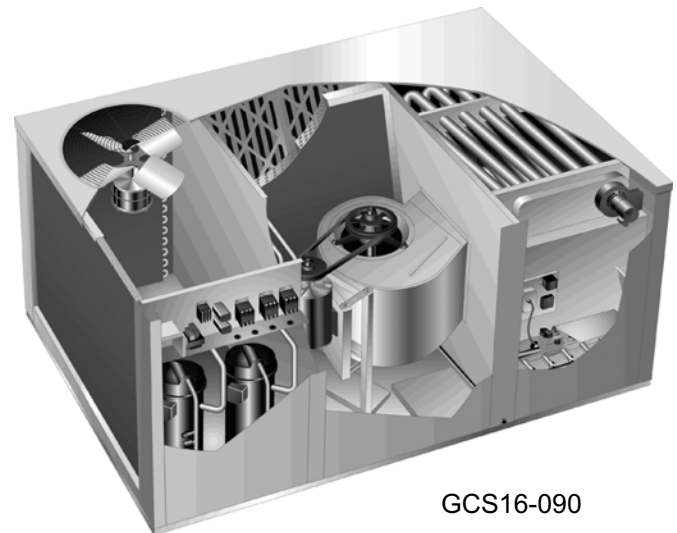

GCS16-090

⚠ WARNING
Improper installation, adjustment, alteration, service or maintenance can cause property damage, personal injury or loss of life. Installation and service must be performed by a qualified installer or service agency.

⚠ WARNING
Refrigerant can be harmful if it is inhaled. Refrigerant must be used and recovered responsibly. Failure to follow this warning may result in personal injury or death.

TABLE OF CONTENTS

GENERAL	1	IV PLACEMENT AND INSTALLATION	30
SPECIFICATIONS	2	V ELECTRICAL CONNECTIONS	30
HIGH ALTITUDE	3	VI INDOOR BLOWER OPERATION	30
ELECTRICAL DATA	4	VII START UP	31
BLOWER DATA	4	VIII REFRIGERATION SERVICE CHECKS	32
OPTIONAL ACCESSORIES	10	IX HEATING SERVICE CHECKS	33
PARTS ARRANGEMENT	12	X MAINTENANCE	35
I APPLICATION	14	XI ACCESSORIES	37
II UNIT COMPONENTS	14	XII WIRING AND OPERATION SEQUENCE	41
III OPTIONAL ELECTRIC HEAT	25		

SPECIFICATIONS

Model No.		GCS/CHA16-072	GCS/CHA16-090
Nominal Tonnage		6	7.5
Cooling Ratings	Gross cooling capacity - Btuh (kW)	74,800 (21.9)	92,800 (27.2)
	★Total cooling capacity - Btuh (kW)	72,000 (21.1)	88,000 (25.8)
	★Total unit kW	8.0	9.8
	★EER (Btuh/Watts)	9.0	9.0
	★Integrated Part Load Value	- - - -	9.5
Refrigerant Charge (HCFC-22)	Circuit 1	9 lbs. 8 oz. (4.31 kg)	6 lbs. 0 oz. (2.72 kg)
	Circuit 2	- - - -	6 lbs. 0 oz. (2.72 kg)
Evaporator Blower and Drive Selection	Blower wheel nominal diameter x width - in. (mm)		12 x 12 (305 x 305)
	Factory Installed ☐ Drives	Nominal motor hp (kW)	2 (1.5)
		Maximum usable hp (kW)	2.30 (1.7)
		Voltage & phase	208/230/460v or 575v-3ph
	RPM range	845 - 1130	
Evaporator Coil	Net face area - sq. ft. (m ²)		7.75 (0.72)
	Tube diameter - in. (mm) & No. of rows		3/8 (9.5) - 3
	Fins per inch (m)		14 (551)
	Expansion device type		Thermostatic Expansion Valve
	Drain connection size mpt - in. (mm)		1 (25.4)
Condenser Coil	Net face area - sq. ft. (m ²)		13.0 (1.21) 15.67 (1.46)
	Tube diameter - in. (mm) & No. of rows		3/8 (9.5) - 2
	Fins per inch (m)		20 (787)
Condenser Fan	Diameter - in. (mm) & No. of blades		(1) 24 (610) - 3 (1) 24 (610) - 4
	Air volume - cfm (L/s)		4100 (1935) 5150 (2430)
	Motor horsepower (W)		(1) 1/3 (249) (1) 3/4 (560)
	Motor rpm		1075
	Motor watts		450 650
Sea Level Two Stage Heating Capacity	Input (low) - Btuh (kW) Natural Gas/LPG-Propane		105,000/101,000 (30.7/29.5) 131,000/126,000 (38.4/36.9)
	Input (High) - Btuh (kW) Natural Gas/LPG-Propane		160,000/140,000 (46.9/41.0) 200,000/175,000 (58.6/51.3)
	Output (High) - Btuh (kW) Natural Gas/LPG-Propane		128,000/114,000 (37.5/33.4) 160,000/142,000 (46.9/41.8)
	A.G.A./C.G.A. Thermal Efficiency Natural Gas/LPG-Propane		80.0%/81.4% 80.0%/81.1%
Gas Supply Connections fpt - in. (mm) Natural and LPG/Propane		3/4 (19)	
Recommended Gas Supply Pressure - wc. in. (kPa)	Natural		7 (1.7)
	LPG/Propane		11 (2.7)
Filters (furnished)	Type of filter		Disposable, pleated
	No. & size - in. (mm)		(4) 16 x 20 x 2 (406 x 508 x 51)
Net weight of basic unit - lbs. (kg)		760 (345)	875 (397)
Shipping weight of basic unit - lbs. (kg) (1 Package)		900 (408)	1060 (481)
Electrical characteristics		208/230v, 460v or 575v - 60 hertz - 3 phase	

*Sound Rating Number in accordance with test conditions included in ARI Standard 270.

★Rated in accordance with ARI Standard 210/240 (-072, -090, -120) or 340/360 (-150);

95°F (35°F) outdoor air temperature and 80°F (27°C) db/67°F (19°C) wb entering evaporator air.

NOTE - Integrated Part Load Value rated at 80°F (27°C) outdoor air temperature.

NOTE - ARI capacity is net and includes evaporator blower motor heat deduction. Gross capacity does not include evaporator blower motor heat deduction.

☐ Using total air volume and system static pressure requirements determine from blower performance tables rpm and motor output required. Maximum usable output of motors furnished by Lennox are shown. In Canada, nominal motor output is also maximum usable motor output. If motors of comparable output are used, be sure to keep within the service factor limitations outlined on the motor nameplate.

SPECIFICATIONS

Model No.		GCS/CHA16-120	GCS/CHA16-150	
Nominal Tonnage		10	12.5	
Cooling Ratings	Gross cooling capacity - Btuh (kW)	123,000 (36.0)	150,000 (44.0)	
	★Total cooling capacity - Btuh (kW)	117,000 (34.3)	144,000 (42.2)	
	★Total unit kW	13.0	16.0	
	★EER (Btuh/Watts)	9.0		
	★Integrated Part Load Value	9.2	8.5	
	*Sound Rating Number (db)	82	88	
Refrigerant Charge (HCFC-22)	Circuit 1	7 lbs. 8 oz. (3.4 kg)	8 lbs. 8 oz. (3.9 kg)	
	Circuit 2	7 lbs. 8 oz. (3.4 kg)	8 lbs. 8 oz. (3.9 kg)	
Evaporator Blower and Drive Selection	Blower wheel nominal diameter x width - in. (mm)		15 x 15 (381 x 381)	
	Factory Installed Drive s	Nominal motor hp (kW)	3 (2.2)	3 (2.2)
		Maximum usable hp (kW)	3.45 (2.6)	3.45 (2.6)
		Voltage & phase	208/230/460v or 575v-3ph	
		RPM range	735 - 1015	
Evaporator Coil	Net face area - sq. ft. (m ²)	9.46 (0.88)	11.92 (1.11)	
	Tube diameter - in. (mm) & No. of rows	3/8 (9.5) - 3	3/8 (9.5) - 4	
	Fins per inch (m)	14 (551)		
	Expansion device type	Thermostatic Expansion Valve		
	Drain connection size mpt - in. (mm)	1 (25.4)		
Condenser Coil	Net face area - sq. ft. (m ²)	24.0 (2.23)		
	Tube diameter - in. (mm) & No. of rows	3/8 (9.5) - 2		
	Fins per inch (m)	20 (787)		
Condenser Fan	Diameter - in. (mm) & No. of blades	(2) 20 (508) - 4	(2) 24 (610) - 3	
	Air volume - cfm (L/s)	6400 (3020)	8400 (3965)	
	Motor horsepower (W)	(2) 1/3 (249)	(2) 1/2 (373)	
	Motor rpm	1075		
	Motor watts	650	1250	
Sea Level Two Stage Heating Capacity	Input (low) - Btuh (kW) Natural Gas/LPG-Propane	177000/170,000 (49.8/51.8)		
	Input (High) - Btuh (kW) Natural Gas/LPG-Propane	270,000/236,000 (79.1/69.1)		
	Output (High) - Btuh (kW) Natural Gas/LPG-Propane	216,000/192,000 (63.3/56.2)		
	A.G.A./C.G.A. Thermal Efficiency Natural Gas/LPG-Propane	80.0%/81.4%		
Gas Supply Connections fpt - in. (mm) Natural and LPG/Propane		3/4 (19)		
Recommended Gas Supply Pressure - wc. in. (kPa)	Natural	7 (1.7)		
	LPG/Propane	11 (2.7)		
Filters (furnished)	Type of filter	Disposable, pleated		
	No. & size - in. (mm)	(2) 16 x 25 x 2 (406 x 635 x 51) & (2) 16 x 20 x 2 (406 x 508 x 51)	(2) 20 x 25 x 2 (508 x 635 x 51) & (2) 20 x 20 x 2 (508 x 508 x 51)	
Net weight of basic unit - lbs. (kg)		1100 (499)	1200 (544)	
Shipping weight of basic unit - lbs. (kg) (1 Package)		1285 (582)	1385 (628)	
Electrical characteristics		208/230v, 460v or 575v - 60 hertz - 3 phase		

*Sound Rating Number in accordance with test conditions included in ARI Standard 270.

★Rated in accordance with ARI Standard 210/240 (-072, -090, -120) or 340/360 (-150);

95°F (35°F) outdoor air temperature and 80°F (27°C) db/67°F (19°C) wb entering evaporator air.

NOTE - Integrated Part Load Value rated at 80°F (27°C) outdoor air temperature.

NOTE - ARI capacity is net and includes evaporator blower motor heat deduction. Gross capacity does not include evaporator blower motor heat deduction.

Using total air volume and system static pressure requirements determine from blower performance tables rpm and motor output required. Maximum usable output of motors furnished by Lennox are shown. In Canada, nominal motor output is also maximum usable motor output. If motors of comparable output are used, be sure to keep within the service factor limitations outlined on the motor nameplate.

HIGH ALTITUDE

Unit ¹	Altitude Ft. (m)	Man. Press. Nat In W.C. (Pa)	Derate	Man. Press. L.P In W.C. (Pa)
GCS16-072/090 ²	0 - 4500 (1372)	3.7 (920)	0%	10.5 (2610)
	4501 - 5500 (1372 - 1676)	3.4 (845)	4%	
	5501 - 6500 (1676 - 1981)	3.1 (770)	8%	
	6501 - 7500 (1981 - 2286)	2.9 (721)	12%	

¹ GCS16-120/150 models require kit HAK16-95 for both natural and LP. No derate required.

² No de-rate for LP units.

ELECTRICAL DATA

Model No.		GCS/CHA16-072			GCS/CHA16-090		
Line voltage data - 60 Hz - 3 phase		208/230v	460v	575v	208/230v	460v	575v
▶ Recommended max. fuse or circuit breaker size (amps)		50	25	20	50	25	20
† Minimum Circuit Ampacity		34	17	14	42	21	17
Compressors	Rated load amps - each (total)	18.8	9.1	7.5	13.3 (26.6)	6.7 (13.4)	5.4 (10.8)
	Locked rotor amps - each (total)	156	70	54	91 (182)	46 (92)	37 (74)
Condenser Fan Motor	Full load amps	2.4	1.3	1.0	3.7	1.9	1.6
	Locked rotor amps	4.7	2.4	1.9	7.3	3.7	2.9
Evaporator Blower Motor	Motor Output - hp (Kw)	2 (1.5)			2 (1.5)		
	Full load amps	7.5	3.4	2.7	7.5	3.7	2.7
	Locked rotor amps	41	20.4	16.2	41.0	20.4	16.2

† Refer to National or Canadian Electrical Code manual to determine wire, fuse and disconnect size requirements.
 ▶ Where current does not exceed 100 amps, HACR type circuit breaker may be used in place of fuse (U.S. only).
 NOTE - Extremes of operating range are plus and minus 10 % of line voltage.

ELECTRICAL DATA

Model No.		GCS/CHA16-120			GCS/CHA16-150		
Line voltage data - 60 Hz - 3 phase		208/230v	460v	575v	208/230v	460v	575v
▶ Recommended max. fuse or circuit breaker size (amps)		70	35	25	70	35	30
† Minimum Circuit Ampacity		58	28	21	59	29	24
Compressors (2)	Rated load amps - each (total)	18.6 (37.2)	8.8 (17.7)	6.6 (13.2)	18.8 (37.6)	9.1 (18.2)	7.5 (15.0)
	Locked rotor amps - each (total)	128 (256)	63 (126)	49 (98)	156 (312)	70 (140)	54 (108)
Condenser Fan Motors	Full load amps - total	(2) 4.8	(2) 2.6	(2) 2.0	(2) 6.0	(2) 3.0	(2) 2.4
	Locked rotor amps - total	(2) 9.4	(2) 4.8	(2) 3.8	(2) 12.0	(2) 6.0	(2) 5.8
Evaporator Blower Motor	Motor Output - hp (Kw)	3 (2.2)					
	Full load amps	10.6	4.8	3.9	10.6	4.8	3.9
	Locked rotor amps	66	26.8	23.4	66	26.8	23.4

† Refer to National or Canadian Electrical Code manual to determine wire, fuse and disconnect size requirements.
 ▶ Where current does not exceed 100 amps, HACR type circuit breaker may be used in place of fuse (U.S. only).
 NOTE - Extremes of operating range are plus and minus 10 % of line voltage.

BLOWER DATA

GCS16-072/090 BLOWER PERFORMANCE																								
BOLD DATA INDICATES FIELD FURNISHED DRIVE																								
Air Volume cfm (L/s)	STATIC PRESSURE EXTERNAL TO UNIT — Inches Water Gauge (Pa)																							
	.20 (50)		.30 (75)		.40 (100)		.50 (125)		.60 (150)		.70 (175)		.80 (200)		.90 (225)		1.00 (250)		1.10 (275)		1.20 (300)		1.30 (325)	
	RPM	BHP (kW)	RPM	BHP (kW)	RPM	BHP (kW)	RPM	BHP (kW)	RPM	BHP (kW)	RPM	BHP (kW)	RPM	BHP (kW)	RPM	BHP (kW)	RPM	BHP (kW)	RPM	BHP (kW)	RPM	BHP (kW)	RPM	BHP (kW)
2000 (945)	600 0.35	655 0.40	705 0.50	755 0.55	800 0.60	845 0.70	890 0.75	930 0.85	970 0.90	1015 1.00	1050 1.05	1090 1.15	1135 1.25	1180 1.35	1225 1.45	1270 1.55	1315 1.65	1360 1.75	1405 1.85	1450 1.95	1495 2.05	1540 2.15	1585 2.25	1630 2.35
2200 (1040)	640 0.45	690 0.50	735 0.55	780 0.65	825 0.70	870 0.80	910 0.85	950 0.95	990 1.05	1030 1.10	1065 1.20	1100 1.30	1140 1.40	1180 1.50	1220 1.60	1260 1.70	1300 1.80	1340 1.90	1380 2.00	1420 2.10	1460 2.20	1500 2.30	1540 2.40	1580 2.50
2400 (1135)	680 0.55	725 0.60	770 0.70	815 0.75	855 0.85	895 0.90	935 1.00	975 1.10	1010 1.15	1045 1.25	1085 1.35	1120 1.45	1155 1.55	1190 1.65	1225 1.75	1260 1.85	1295 1.95	1330 2.05	1365 2.15	1400 2.25	1435 2.35	1470 2.45	1505 2.55	1540 2.65
2600 (1225)	720 0.70	765 0.75	805 0.80	845 0.90	885 1.00	925 1.05	960 1.15	1000 1.25	1035 1.30	1070 1.40	1105 1.50	1140 1.60	1175 1.70	1210 1.80	1245 1.90	1280 2.00	1315 2.10	1350 2.20	1385 2.30	1420 2.40	1455 2.50	1490 2.60	1525 2.70	1560 2.80
2800 (1320)	765 0.85	805 0.90	845 1.00	880 1.05	920 1.15	955 1.25	990 1.30	1025 1.40	1060 1.50	1095 1.60	1125 1.70	1160 1.80	1195 1.90	1230 2.00	1265 2.10	1300 2.20	1335 2.30	1370 2.40	1405 2.50	1440 2.60	1475 2.70	1510 2.80	1545 2.90	1580 3.00
3000 (1415)	805 1.00	845 1.05	880 1.15	920 1.25	955 1.35	990 1.40	1020 1.50	1055 1.60	1090 1.70	1120 1.80	1150 1.90	1185 2.00	1220 2.10	1255 2.20	1290 2.30	1325 2.40	1360 2.50	1395 2.60	1430 2.70	1465 2.80	1500 2.90	1535 3.00	1570 3.10	1605 3.20
3200 (1510)	850 (0.90)	885 (0.93)	920 (1.01)	955 (1.08)	990 (1.16)	1020 (1.19)	1055 (1.27)	1085 (1.34)	1120 (1.42)	1150 (1.49)	1180 (1.57)	1210 (1.68)	1240 (1.79)	1270 (1.90)	1300 (2.00)	1330 (2.10)	1360 (2.20)	1390 (2.30)	1420 (2.40)	1450 (2.50)	1480 (2.60)	1510 (2.70)	1540 (2.80)	1570 (2.90)
3400 (1605)	895 (1.04)	930 (1.12)	960 (1.16)	995 (1.23)	1025 (1.31)	1060 (1.38)	1090 (1.45)	1120 (1.53)	1150 (1.60)	1180 (1.68)	1210 (1.79)	1240 (1.87)	1270 (1.98)	1300 (2.09)	1330 (2.20)	1360 (2.30)	1390 (2.40)	1420 (2.50)	1450 (2.60)	1480 (2.70)	1510 (2.80)	1540 (2.90)	1570 (3.00)	1600 (3.10)
3600 (1700)	940 (1.23)	970 (1.27)	1005 (1.38)	1035 (1.42)	1065 (1.49)	1095 (1.57)	1125 (1.64)	1155 (1.75)	1185 (1.83)	1210 (1.90)	1240 (1.98)	1270 (2.09)	1300 (2.20)	1330 (2.30)	1360 (2.40)	1390 (2.50)	1420 (2.60)	1450 (2.70)	1480 (2.80)	1510 (2.90)	1540 (3.00)	1570 (3.10)	1600 (3.20)	1630 (3.30)
3800 (1795)	985 (1.42)	1015 (1.49)	1045 (1.57)	1075 (1.64)	1105 (1.72)	1135 (1.79)	1160 (1.87)	1190 (1.98)	1220 (2.05)	1245 (2.13)	1270 (2.20)	1300 (2.30)	1330 (2.40)	1360 (2.50)	1390 (2.60)	1420 (2.70)	1450 (2.80)	1480 (2.90)	1510 (3.00)	1540 (3.10)	1570 (3.20)	1600 (3.30)	1630 (3.40)	

NOTE — All data is measured external to the unit with dry coil and with the air filters in place.
 NOTE — In Canada, maximum usable motor output is 2 hp (1.5 kW).

BLOWER DATA

GCS16-120 BLOWER PERFORMANCE														
BOLD DATA INDICATES FIELD FURNISHED DRIVE														
Air Volume cfm (L/s)	STATIC PRESSURE EXTERNAL TO UNIT — Inches Water Gauge (Pa)													
	.20 (50)	.30 (75)	.40 (100)	.50 (125)	.60 (150)	.70 (175)	.80 (200)	.90 (225)	1.00 (250)	1.10 (275)	1.20 (300)	1.30 (325)	1.40 (350)	1.50 (375)
	RPM BHP (kW)	RPM BHP (kW)	RPM BHP (kW)	RPM BHP (kW)	RPM BHP (kW)	RPM BHP (kW)	RPM BHP (kW)	RPM BHP (kW)	RPM BHP (kW)	RPM BHP (kW)	RPM BHP (kW)	RPM BHP (kW)	RPM BHP (kW)	RPM BHP (kW)
3000 (1415)	515 0.50 (0.37)	555 0.60 (0.45)	595 0.65 (0.48)	635 0.75 (0.56)	670 0.80 (0.60)	705 0.90 (0.67)	740 1.00 (0.75)	775 1.10 (0.82)	810 1.15 (0.86)	845 1.30 (0.97)	875 1.35 (1.01)	905 1.45 (1.08)	940 1.60 (1.19)	970 1.70 (1.27)
3200 (1510)	535 0.60 (0.45)	575 0.65 (0.48)	615 0.75 (0.56)	650 0.85 (0.63)	685 0.90 (0.67)	720 1.00 (0.75)	755 1.10 (0.82)	790 1.20 (0.90)	820 1.30 (0.97)	850 1.40 (1.04)	885 1.50 (1.12)	915 1.60 (1.19)	945 1.70 (1.27)	975 1.80 (1.34)
3400 (1605)	560 0.70 (0.52)	600 0.80 (0.60)	635 0.85 (0.63)	670 0.95 (0.71)	705 1.05 (0.78)	735 1.10 (0.82)	770 1.20 (0.90)	800 1.30 (0.97)	830 1.40 (1.04)	865 1.50 (1.12)	895 1.65 (1.23)	925 1.75 (1.31)	950 1.85 (1.38)	980 1.95 (1.45)
3600 (1700)	585 0.80 (0.60)	620 0.90 (0.67)	655 1.00 (0.75)	690 1.05 (0.78)	720 1.15 (0.86)	755 1.25 (0.93)	785 1.35 (1.01)	815 1.45 (1.08)	845 1.55 (1.16)	875 1.65 (1.23)	905 1.75 (1.31)	935 1.90 (1.42)	960 2.00 (1.49)	990 2.10 (1.57)
3800 (1795)	610 0.95 (0.71)	645 1.00 (0.75)	675 1.10 (0.82)	710 1.20 (0.90)	740 1.30 (0.97)	770 1.40 (1.04)	800 1.50 (1.12)	830 1.60 (1.19)	860 1.70 (1.27)	890 1.80 (1.34)	915 1.90 (1.42)	945 2.05 (1.53)	970 2.15 (1.60)	1000 2.25 (1.68)
4000 (1890)	635 1.05 (0.78)	670 1.15 (0.86)	700 1.25 (0.93)	730 1.35 (1.01)	760 1.45 (1.08)	790 1.55 (1.16)	820 1.65 (1.23)	845 1.75 (1.31)	875 1.85 (1.38)	900 1.95 (1.45)	930 2.10 (1.57)	955 2.20 (1.64)	985 2.35 (1.75)	1010 2.45 (1.83)
4200 (1980)	660 1.20 (0.90)	690 1.30 (0.97)	720 1.40 (1.04)	750 1.50 (1.12)	780 1.60 (1.19)	810 1.70 (1.27)	835 1.80 (1.34)	865 1.95 (1.45)	890 2.05 (1.53)	920 2.15 (1.60)	945 2.25 (1.68)	970 2.40 (1.79)	995 2.50 (1.87)	1020 2.60 (1.94)
4400 (2075)	690 1.40 (1.04)	715 1.45 (1.08)	745 1.60 (1.19)	775 1.70 (1.27)	800 1.80 (1.34)	830 1.90 (1.42)	855 2.00 (1.49)	880 2.10 (1.57)	910 2.25 (1.68)	935 2.35 (1.75)	960 2.45 (1.83)	985 2.60 (1.94)	1010 2.70 (2.01)	1035 2.85 (2.13)
4600 (2170)	715 1.55 (1.16)	740 1.65 (1.23)	770 1.75 (1.31)	795 1.85 (1.38)	825 2.00 (1.49)	850 2.10 (1.57)	875 2.20 (1.64)	900 2.30 (1.72)	925 2.45 (1.83)	950 2.55 (1.90)	975 2.65 (1.98)	1000 2.80 (2.09)	1025 2.95 (2.20)	1050 3.05 (2.28)
4800 (2265)	740 1.75 (1.31)	765 1.85 (1.38)	795 1.95 (1.45)	820 2.10 (1.57)	845 2.20 (1.64)	870 2.30 (1.72)	895 2.40 (1.79)	920 2.55 (1.90)	945 2.65 (1.98)	970 2.80 (2.09)	995 2.90 (2.16)	1015 3.00 (2.24)	1040 3.15 (2.35)	1065 3.30 (2.46)
5000 (2360)	765 1.95 (1.45)	790 2.05 (1.53)	820 2.20 (1.64)	845 2.30 (1.72)	870 2.40 (1.79)	890 2.50 (1.87)	915 2.65 (1.98)	940 2.75 (2.05)	965 2.90 (2.16)	990 3.05 (2.28)	1010 3.15 (2.35)	1035 3.30 (2.46)	1055 3.40 (2.54)	----
5200 (2455)	795 2.20 (1.64)	820 2.30 (1.72)	840 2.40 (1.79)	865 2.50 (1.87)	890 2.65 (1.98)	915 2.80 (2.09)	940 2.90 (2.16)	960 3.00 (2.24)	985 3.15 (2.35)	1005 3.25 (2.42)	1030 3.40 (2.54)	----	----	----

NOTE — All data is measured external to the unit with dry coil and with the air filters in place.

NOTE — In Canada, maximum usable motor output is 3 hp (2.24 kW).

BLOWER DATA

GCS16-150 BLOWER PERFORMANCE															
BOLD DATA INDICATES FIELD FURNISHED DRIVE SHADED DATA INDICATES FIELD FURNISHED MOTOR															
Air Volume cfm (L/s)	STATIC PRESSURE EXTERNAL TO UNIT — Inches Water Gauge (Pa)														
	.20 (50)	.30 (75)	.40 (100)	.50 (125)	.60 (150)	.70 (175)	.80 (200)	.90 (225)	1.00 (250)	1.10 (275)	1.20 (300)	1.30 (325)	1.40 (350)	1.50 (375)	1.60 (400)
	RPM BHP (kW)	RPM BHP (kW)	RPM BHP (kW)	RPM BHP (kW)	RPM BHP (kW)	RPM BHP (kW)	RPM BHP (kW)	RPM BHP (kW)	RPM BHP (kW)	RPM BHP (kW)	RPM BHP (kW)	RPM BHP (kW)	RPM BHP (kW)	RPM BHP (kW)	RPM BHP (kW)
3800 (1795)	620 1.05 (0.78)	655 1.15 (0.86)	695 1.25 (0.93)	725 1.35 (1.01)	760 1.45 (1.08)	795 1.55 (1.16)	825 1.70 (1.27)	860 1.80 (1.34)	890 1.95 (1.45)	920 2.05 (1.53)	945 2.15 (1.60)	975 2.30 (1.72)	1005 2.45 (1.83)	1030 2.55 (1.90)	1055 2.70 (2.01)
3900 (1840)	630 1.10 (0.82)	665 1.20 (0.90)	705 1.30 (0.97)	740 1.45 (1.08)	770 1.55 (1.16)	805 1.65 (1.23)	835 1.75 (1.31)	865 1.90 (1.42)	895 2.00 (1.49)	925 2.15 (1.60)	955 2.25 (1.68)	980 2.40 (1.79)	1010 2.55 (1.90)	1035 2.65 (1.98)	1060 2.80 (2.09)
4000 (1890)	645 1.20 (0.90)	680 1.30 (0.97)	715 1.40 (1.04)	750 1.50 (1.12)	780 1.60 (1.19)	815 1.75 (1.31)	845 1.85 (1.38)	875 2.00 (1.49)	905 2.10 (1.57)	935 2.25 (1.68)	960 2.35 (1.75)	990 2.50 (1.87)	1015 2.65 (1.98)	1040 2.75 (2.05)	1070 2.90 (2.16)
4100 (1935)	655 1.25 (0.93)	690 1.35 (1.01)	725 1.50 (1.12)	760 1.60 (1.19)	790 1.70 (1.27)	820 1.85 (1.38)	855 1.95 (1.45)	885 2.10 (1.57)	910 2.20 (1.64)	940 2.35 (1.75)	970 2.50 (1.87)	995 2.60 (1.94)	1020 2.70 (2.01)	1050 2.90 (2.16)	1075 3.00 (2.24)
4200 (1980)	670 1.35 (1.01)	705 1.45 (1.08)	735 1.55 (1.16)	770 1.70 (1.27)	800 1.80 (1.34)	830 1.90 (1.42)	860 2.05 (1.53)	890 2.15 (1.60)	920 2.30 (1.72)	950 2.45 (1.83)	975 2.55 (1.90)	1005 2.70 (2.01)	1030 2.85 (2.13)	1055 3.00 (2.24)	1080 3.10 (2.31)
4300 (2030)	680 1.40 (1.04)	715 1.55 (1.16)	750 1.65 (1.23)	780 1.80 (1.34)	810 1.90 (1.42)	840 2.00 (1.49)	870 2.15 (1.60)	900 2.30 (1.72)	930 2.40 (1.79)	955 2.55 (1.90)	985 2.70 (2.01)	1010 2.80 (2.09)	1035 2.95 (2.20)	1060 3.10 (2.31)	1085 3.25 (2.42)
4400 (2075)	695 1.50 (1.12)	725 1.65 (1.23)	760 1.75 (1.31)	790 1.90 (1.42)	820 2.00 (1.49)	850 2.10 (1.57)	880 2.25 (1.68)	910 2.40 (1.79)	935 2.50 (1.87)	965 2.65 (1.98)	990 2.80 (2.09)	1020 2.95 (2.20)	1045 3.10 (2.31)	1070 3.20 (2.39)	1095 3.35 (2.50)
4500 (2125)	705 1.60 (1.19)	740 1.75 (1.31)	770 1.85 (1.38)	800 1.95 (1.45)	830 2.10 (1.57)	860 2.25 (1.68)	890 2.35 (1.75)	920 2.50 (1.87)	945 2.65 (1.98)	975 2.80 (2.09)	1000 2.90 (2.16)	1025 3.05 (2.28)	1050 3.20 (2.39)	1075 3.35 (2.50)	1100 3.50 (2.61)
4600 (2170)	720 1.70 (1.27)	750 1.85 (1.38)	780 1.95 (1.45)	815 2.10 (1.57)	840 2.20 (1.64)	870 2.35 (1.75)	900 2.50 (1.87)	930 2.65 (1.98)	955 2.75 (2.05)	980 2.90 (2.16)	1010 3.05 (2.28)	1035 3.20 (2.39)	1060 3.35 (2.50)	1085 3.50 (2.61)	1110 3.65 (2.72)
4700 (2220)	730 1.80 (1.34)	765 1.95 (1.45)	795 2.05 (1.53)	825 2.20 (1.64)	855 2.35 (1.75)	880 2.45 (1.83)	910 2.60 (1.94)	935 2.75 (2.05)	965 2.90 (2.16)	990 3.00 (2.24)	1015 3.15 (2.35)	1040 3.30 (2.46)	1065 3.45 (2.57)	1090 3.60 (2.69)	1115 3.75 (2.80)
4800 (2265)	745 1.90 (1.42)	775 2.05 (1.53)	805 2.20 (1.64)	835 2.30 (1.72)	865 2.45 (1.83)	890 2.55 (1.90)	920 2.70 (2.01)	945 2.85 (2.13)	975 3.00 (2.24)	1000 3.15 (2.35)	1025 3.30 (2.46)	1050 3.45 (2.57)	1075 3.60 (2.69)	1100 3.75 (2.80)	1125 3.90 (2.91)
4900 (2310)	755 2.00 (1.49)	785 2.15 (1.60)	820 2.30 (1.72)	845 2.40 (1.79)	875 2.55 (1.90)	900 2.70 (2.01)	930 2.85 (2.13)	955 3.00 (2.24)	985 3.15 (2.35)	1010 3.30 (2.46)	1035 3.45 (2.57)	1060 3.60 (2.69)	1085 3.75 (2.80)	1105 3.85 (2.87)	1130 4.05 (3.02)
5000 (2360)	770 2.15 (1.60)	800 2.30 (1.72)	830 2.40 (1.79)	860 2.55 (1.90)	885 2.70 (2.01)	915 2.85 (2.13)	940 3.00 (2.24)	965 3.10 (2.31)	990 3.25 (2.42)	1020 3.45 (2.57)	1040 3.55 (2.65)	1065 3.70 (2.76)	1090 3.85 (2.87)	1115 4.05 (3.02)	1140 4.20 (3.13)
5100 (2405)	785 2.25 (1.68)	815 2.40 (1.79)	840 2.55 (1.90)	870 2.70 (2.01)	895 2.80 (2.09)	925 2.95 (2.20)	950 3.10 (2.31)	975 3.25 (2.42)	1000 3.40 (2.54)	1025 3.55 (2.65)	1050 3.70 (2.76)	1075 3.85 (2.87)	1100 4.00 (2.98)	1125 4.20 (3.13)	1145 4.30 (3.21)
5200 (2455)	795 2.40 (1.79)	825 2.55 (1.90)	855 2.70 (2.01)	880 2.80 (2.09)	910 2.95 (2.20)	935 3.10 (2.31)	960 3.25 (2.42)	985 3.40 (2.54)	1010 3.55 (2.65)	1035 3.70 (2.76)	1060 3.85 (2.87)	1085 4.00 (2.98)	1110 4.20 (3.13)	1130 4.30 (3.21)	1155 4.50 (3.36)
5300 (2500)	810 2.50 (1.87)	840 2.65 (1.98)	865 2.80 (2.09)	895 2.95 (2.20)	920 3.10 (2.31)	945 3.25 (2.42)	970 3.40 (2.54)	995 3.55 (2.65)	1020 3.70 (2.76)	1045 3.85 (2.87)	1070 4.00 (2.98)	1095 4.20 (3.13)	1115 4.30 (3.21)	1140 4.50 (3.36)	1165 4.65 (3.47)
5400 (2550)	825 2.65 (1.98)	850 2.80 (2.09)	880 2.95 (2.20)	905 3.10 (2.31)	930 3.25 (2.42)	955 3.40 (2.54)	980 3.55 (2.65)	1005 3.70 (2.76)	1030 3.85 (2.87)	1055 4.00 (2.98)	1080 4.15 (3.10)	1105 4.35 (3.25)	1125 4.50 (3.36)	1150 4.65 (3.47)	1170 4.80 (3.58)
5500 (2595)	835 2.80 (2.09)	865 2.95 (2.20)	890 3.10 (2.31)	915 3.25 (2.42)	945 3.40 (2.54)	970 3.55 (2.65)	995 3.70 (2.76)	1020 3.85 (2.87)	1040 4.00 (2.98)	1065 4.15 (3.10)	1090 4.35 (3.25)	1110 4.50 (3.36)	1135 4.65 (3.47)	1155 4.80 (3.58)	1180 5.00 (3.73)
5600 (2645)	850 2.95 (2.20)	875 3.10 (2.31)	900 3.20 (2.39)	930 3.40 (2.54)	955 3.55 (2.65)	980 3.70 (2.76)	1005 3.85 (2.87)	1030 4.05 (3.02)	1050 4.15 (3.10)	1075 4.35 (3.25)	1100 4.50 (3.36)	1120 4.65 (3.47)	1145 4.85 (3.62)	1165 5.00 (3.73)	1190 5.20 (3.88)
5700 (2690)	860 3.10 (2.31)	890 3.25 (2.42)	915 3.40 (2.54)	940 3.55 (2.65)	965 3.70 (2.76)	990 3.85 (2.87)	1015 4.00 (2.98)	1040 4.20 (3.13)	1060 4.35 (3.25)	1085 4.50 (3.36)	1110 4.70 (3.51)	1130 4.85 (3.62)	1155 5.00 (3.73)	1175 5.20 (3.88)	1195 5.35 (3.99)
5800 (2735)	875 3.25 (2.42)	900 3.40 (2.54)	925 3.55 (2.65)	955 3.70 (2.76)	975 3.85 (2.87)	1000 4.00 (2.98)	1025 4.20 (3.13)	1050 4.35 (3.25)	1075 4.55 (3.39)	1095 4.70 (3.51)	1120 4.85 (3.62)	1140 5.00 (3.73)	1165 5.20 (3.88)	1185 5.35 (3.99)	1205 5.55 (4.14)
5900 (2785)	890 3.40 (2.54)	915 3.55 (2.65)	940 3.70 (2.76)	965 3.90 (2.91)	990 4.05 (3.02)	1015 4.20 (3.13)	1035 4.35 (3.25)	1060 4.55 (3.39)	1085 4.70 (3.51)	1105 4.85 (3.62)	1130 5.05 (3.77)	1150 5.20 (3.88)	1170 5.35 (3.99)	1195 5.55 (4.14)	1215 5.75 (4.29)
6000 (2830)	900 3.55 (2.65)	925 3.70 (2.76)	950 3.85 (2.87)	975 4.05 (3.02)	1000 4.20 (3.13)	1025 4.40 (3.28)	1050 4.55 (3.39)	1070 4.70 (3.51)	1095 4.90 (3.66)	1115 5.05 (3.77)	1140 5.25 (3.92)	1160 5.40 (4.03)	1180 5.55 (4.14)	1205 5.75 (4.29)	1225 5.95 (4.44)

NOTE — All data is measured external to the unit with dry coil and with the air filters in place.

NOTE — In Canada, maximum usable motor output is 3 hp (2.24 kW).

BLOWER DATA

CHA16-072/090 BLOWER PERFORMANCE																									
BOLD DATA INDICATES FIELD FURNISHED DRIVE																									
Air Volume cfm (L/s)	STATIC PRESSURE EXTERNAL TO UNIT — Inches Water Gauge (Pa)																								
	.20(50)		.30(75)		.40(100)		.50(125)		.60(150)		.70(175)		.80(200)		.90(225)		1.00(250)		1.10(275)		1.20(300)		1.30(325)		
	RPM	BHP (kW)	RPM	BHP (kW)	RPM	BHP (kW)	RPM	BHP (kW)	RPM	BHP (kW)	RPM	BHP (kW)	RPM	BHP (kW)	RPM	BHP (kW)	RPM	BHP (kW)	RPM	BHP (kW)	RPM	BHP (kW)	RPM	BHP (kW)	RPM
2000 (945)	585	0.35 (0.26)	630	0.40 (0.30)	680	0.45 (0.34)	725	0.50 (0.37)	775	0.60 (0.45)	820	0.65 (0.48)	865	0.75 (0.56)	910	0.80 (0.60)	955	0.90 (0.67)	1000	0.95 (0.71)	1045	1.05 (0.78)	1090	1.15 (0.86)	
2200 (1040)	625	0.45 (0.34)	670	0.50 (0.37)	710	0.55 (0.41)	755	0.65 (0.48)	795	0.70 (0.52)	840	0.75 (0.56)	880	0.85 (0.63)	925	0.90 (0.67)	965	1.00 (0.75)	1005	1.05 (0.78)	1050	1.15 (0.86)	1090	1.25 (0.93)	
2400 (1135)	665	0.55 (0.41)	705	0.60 (0.45)	745	0.70 (0.52)	785	0.75 (0.56)	825	0.80 (0.60)	865	0.90 (0.67)	905	0.95 (0.71)	940	1.05 (0.78)	980	1.10 (0.82)	1020	1.20 (0.90)	1055	1.30 (0.97)	1095	1.40 (1.04)	
2600 (1225)	710	0.70 (0.52)	745	0.75 (0.56)	780	0.80 (0.60)	820	0.90 (0.67)	855	0.95 (0.71)	890	1.05 (0.78)	930	1.10 (0.82)	965	1.20 (0.90)	1000	1.30 (0.97)	1035	1.35 (1.01)	1070	1.45 (1.08)	1105	1.55 (1.16)	
2800 (1320)	750	0.85 (0.63)	785	0.90 (0.67)	820	0.95 (0.71)	855	1.05 (0.78)	890	1.10 (0.82)	925	1.20 (0.90)	955	1.30 (0.97)	990	1.35 (1.01)	1025	1.45 (1.08)	1055	1.55 (1.16)	1090	1.65 (1.23)	1125	1.75 (1.31)	
3000 (1415)	795	1.00 (0.75)	830	1.05 (0.78)	860	1.15 (0.86)	890	1.20 (0.90)	925	1.30 (0.97)	955	1.40 (1.04)	985	1.45 (1.08)	1020	1.55 (1.16)	1050	1.65 (1.23)	1080	1.75 (1.31)	1115	1.85 (1.38)	1145	1.95 (1.45)	
3200 (1510)	840	1.20 (0.90)	870	1.25 (0.93)	900	1.35 (1.01)	930	1.40 (1.04)	960	1.50 (1.12)	990	1.60 (1.19)	1020	1.70 (1.27)	1050	1.75 (1.31)	1080	1.85 (1.38)	1110	1.95 (1.45)	1140	2.05 (1.53)	1170	2.15 (1.60)	
3400 (1605)	885	1.40 (1.04)	915	1.50 (1.12)	940	1.55 (1.16)	970	1.65 (1.23)	1000	1.75 (1.31)	1025	1.80 (1.34)	1055	1.90 (1.42)	1085	2.00 (1.49)	1110	2.10 (1.57)	1140	2.20 (1.64)	1165	2.30 (1.72)	1195	2.40 (1.79)	
3600 (1700)	930	1.65 (1.23)	960	1.75 (1.31)	985	1.80 (1.34)	1010	1.90 (1.42)	1040	2.00 (1.49)	1065	2.10 (1.57)	1090	2.20 (1.64)	1120	2.30 (1.72)	1145	2.40 (1.79)	1170	2.50 (1.87)	1200	2.60 (1.94)	1225	2.70 (2.01)	
3800 (1795)	975	1.90 (1.42)	1005	2.00 (1.49)	1030	2.10 (1.57)	1055	2.20 (1.64)	1080	2.30 (1.72)	1105	2.40 (1.79)	1130	2.50 (1.87)	1155	2.60 (1.94)	1180	2.70 (2.01)	1205	2.80 (2.09)	1230	2.90 (2.16)	1255	3.00 (2.24)	

NOTE — All data is measured external to the unit with dry coil and with the air filters in place. See Page 9 for Accessory Air Resistance data.
 NOTE — In Canada, maximum usable motor output is 2 hp (1.5 kW).

CHA16-120 BLOWER PERFORMANCE																															
BOLD DATA INDICATES FIELD FURNISHED DRIVE																															
Air Volume cfm (L/s)	STATIC PRESSURE EXTERNAL TO UNIT — Inches Water Gauge (Pa)																														
	.20 (50)		.30 (75)		.40 (100)		.50 (125)		.60 (150)		.70 (175)		.80 (200)		.90 (225)		1.00 (250)		1.10 (275)		1.20 (300)		1.30 (325)		1.40 (350)		1.50 (375)				
	RPM	BHP (kW)	RPM	BHP (kW)	RPM	BHP (kW)	RPM	BHP (kW)	RPM	BHP (kW)	RPM	BHP (kW)	RPM	BHP (kW)	RPM	BHP (kW)	RPM	BHP (kW)	RPM	BHP (kW)	RPM	BHP (kW)	RPM	BHP (kW)	RPM	BHP (kW)	RPM	BHP (kW)	RPM	BHP (kW)	RPM
3000 (1415)	510	0.50 (0.37)	550	0.60 (0.45)	585	0.65 (0.48)	620	0.70 (0.52)	655	0.80 (0.60)	690	0.85 (0.63)	720	0.95 (0.71)	750	1.00 (0.75)	780	1.05 (0.78)	810	1.15 (0.86)	840	1.20 (0.90)	870	1.30 (0.97)	895	1.40 (1.04)	925	1.45 (1.08)			
3200 (1510)	535	0.60 (0.45)	570	0.70 (0.52)	605	0.75 (0.56)	640	0.80 (0.60)	670	0.90 (0.67)	705	0.95 (0.71)	735	1.05 (0.78)	765	1.10 (0.82)	795	1.20 (0.90)	825	1.30 (0.97)	850	1.35 (1.01)	880	1.45 (1.08)	905	1.50 (1.12)	930	1.60 (1.19)			
3400 (1605)	560	0.70 (0.52)	595	0.80 (0.60)	630	0.85 (0.63)	660	0.95 (0.71)	690	1.00 (0.75)	720	1.10 (0.82)	750	1.15 (0.86)	780	1.25 (0.93)	810	1.35 (1.01)	835	1.40 (1.04)	865	1.50 (1.12)	890	1.60 (1.19)	915	1.65 (1.23)	940	1.75 (1.31)			
3600 (1700)	585	0.85 (0.63)	620	0.90 (0.67)	650	1.00 (0.75)	680	1.05 (0.78)	710	1.15 (0.86)	740	1.25 (0.93)	770	1.30 (0.97)	795	1.40 (1.04)	825	1.50 (1.12)	850	1.55 (1.16)	875	1.65 (1.23)	900	1.70 (1.27)	925	1.80 (1.34)	950	1.90 (1.42)			
3800 (1795)	610	0.95 (0.71)	645	1.05 (0.78)	670	1.10 (0.82)	700	1.20 (0.90)	730	1.30 (0.97)	760	1.40 (1.04)	785	1.45 (1.08)	815	1.55 (1.16)	840	1.65 (1.23)	865	1.70 (1.27)	890	1.80 (1.34)	915	1.90 (1.42)	940	2.00 (1.49)	965	2.10 (1.57)			
4000 (1890)	640	1.10 (0.82)	665	1.20 (0.90)	695	1.30 (0.97)	725	1.35 (1.01)	750	1.45 (1.08)	780	1.55 (1.16)	805	1.65 (1.23)	830	1.70 (1.27)	855	1.80 (1.34)	880	1.90 (1.42)	905	2.00 (1.49)	930	2.10 (1.57)	955	2.20 (1.64)	980	2.30 (1.72)			
4200 (1980)	665	1.30 (0.97)	690	1.35 (1.01)	720	1.45 (1.08)	745	1.55 (1.16)	775	1.65 (1.23)	800	1.70 (1.27)	825	1.80 (1.34)	850	1.90 (1.42)	875	2.00 (1.49)	900	2.10 (1.57)	920	2.20 (1.64)	945	2.30 (1.72)	970	2.40 (1.79)	990	2.45 (1.83)			
4400 (2075)	690	1.45 (1.08)	715	1.55 (1.16)	745	1.65 (1.23)	770	1.70 (1.27)	795	1.80 (1.34)	820	1.90 (1.42)	845	2.00 (1.49)	870	2.10 (1.57)	895	2.20 (1.64)	915	2.30 (1.72)	940	2.40 (1.79)	960	2.50 (1.87)	985	2.60 (1.94)	1005	2.70 (2.01)			
4600 (2170)	715	1.65 (1.23)	745	1.75 (1.31)	770	1.85 (1.38)	795	1.95 (1.45)	820	2.05 (1.53)	840	2.10 (1.57)	865	2.20 (1.64)	890	2.30 (1.72)	910	2.40 (1.79)	935	2.50 (1.87)	955	2.60 (1.94)	980	2.75 (2.05)	1000	2.80 (2.09)	1025	2.95 (2.20)			
4800 (2265)	745	1.85 (1.38)	770	1.95 (1.45)	795	2.05 (1.53)	815	2.15 (1.60)	840	2.25 (1.68)	865	2.35 (1.75)	885	2.45 (1.83)	910	2.55 (1.90)	930	2.65 (1.98)	955	2.75 (2.05)	975	2.85 (2.13)	1000	3.00 (2.24)	1020	3.10 (2.31)	1040	3.20 (2.39)			
5000 (2360)	770	2.05 (1.53)	795	2.15 (1.60)	820	2.30 (1.72)	840	2.35 (1.75)	865	2.50 (1.87)	885	2.60 (1.94)	910	2.70 (2.01)	930	2.80 (2.09)	955	2.90 (2.16)	975	3.00 (2.24)	995	3.10 (2.31)	1015	3.25 (2.42)	1035	3.35 (2.50)	1055	3.45 (2.57)			
5200 (2455)	800	2.30 (1.72)	820	2.40 (1.79)	845	2.55 (1.90)	865	2.60 (1.94)	890	2.75 (2.05)	910	2.85 (2.13)	930	2.95 (2.20)	955	3.10 (2.31)	975	3.20 (2.39)	995	3.30 (2.46)	1015	3.40 (2.54)	---	---	---	---					

NOTE — All data is measured external to the unit with dry coil and with the air filters in place. See Page 9 for Accessory Air Resistance data.
 NOTE — In Canada, maximum usable motor output is 3 hp (2.2 kW).

BLOWER DATA

CHA16-150 BLOWER PERFORMANCE															
BOLD DATA INDICATES FIELD FURNISHED DRIVE SHADED DATA INDICATES FIELD FURNISHED MOTOR															
Air Volume cfm (L/s)	STATIC PRESSURE EXTERNAL TO UNIT — Inches Water Gauge (Pa)														
	.20 (50)	.30 (75)	.40 (100)	.50 (125)	.60 (150)	.70 (175)	.80 (200)	.90 (225)	1.00 (250)	1.10 (275)	1.20 (300)	1.30 (325)	1.40 (350)	1.50 (375)	1.60 (400)
	RPM BHP (kW)	RPM BHP (kW)	RPM BHP (kW)	RPM BHP (kW)	RPM BHP (kW)	RPM BHP (kW)	RPM BHP (kW)	RPM BHP (kW)	RPM BHP (kW)	RPM BHP (kW)	RPM BHP (kW)	RPM BHP (kW)	RPM BHP (kW)	RPM BHP (kW)	RPM BHP (kW)
3800 (1795)	580 0.90	615 1.00	650 1.10	680 1.20	710 1.30	740 1.35 (1.01)	765 1.45 (1.08)	795 1.55 (1.16)	820 1.65 (1.23)	845 1.70 (1.27)	870 1.80 (1.34)	895 1.90 (1.42)	920 2.00 (1.49)	940 2.05 (1.53)	965 2.15 (1.60)
3900 (1840)	590 1.00	625 1.05	660 1.15	690 1.25	720 1.35	750 1.45 (1.08)	775 1.55 (1.16)	805 1.65 (1.23)	830 1.75 (1.31)	855 1.80 (1.34)	880 1.90 (1.42)	900 2.00 (1.49)	925 2.10 (1.57)	950 2.20 (1.64)	970 2.25 (1.68)
4000 (1890)	605 1.05	640 1.15	670 1.25	700 1.35	730 1.45	760 1.55 (1.16)	785 1.60 (1.19)	810 1.70 (1.27)	835 1.80 (1.34)	860 1.90 (1.42)	885 2.00 (1.49)	910 2.10 (1.57)	935 2.20 (1.64)	955 2.25 (1.68)	980 2.35 (1.75)
4100 (1935)	615 1.10	650 1.20	680 1.30	710 1.40	740 1.50 (1.12)	765 1.60 (1.19)	795 1.70 (1.27)	820 1.80 (1.34)	845 1.90 (1.42)	870 2.00 (1.49)	895 2.10 (1.57)	915 2.20 (1.64)	940 2.30 (1.72)	965 2.40 (1.79)	985 2.45 (1.83)
4200 (1980)	630 1.20	660 1.30	690 1.40	720 1.50	750 1.60 (1.19)	775 1.70 (1.27)	805 1.80 (1.34)	830 1.90 (1.42)	855 2.00 (1.49)	880 2.10 (1.57)	900 2.20 (1.64)	925 2.30 (1.72)	950 2.40 (1.79)	970 2.50 (1.87)	990 2.55 (1.90)
4300 (2030)	640 1.25	670 1.35	700 1.50	730 1.60	760 1.70 (1.27)	785 1.80 (1.34)	810 1.90 (1.42)	840 2.00 (1.49)	860 2.10 (1.57)	885 2.20 (1.64)	910 2.30 (1.72)	935 2.40 (1.79)	955 2.50 (1.87)	980 2.60 (1.94)	1000 2.70 (2.01)
4400 (2075)	650 1.35	685 1.45	710 1.55	740 1.65 (1.23)	770 1.80 (1.34)	795 1.90 (1.42)	820 2.00 (1.49)	845 2.10 (1.57)	870 2.20 (1.64)	895 2.30 (1.72)	920 2.40 (1.79)	940 2.50 (1.87)	965 2.60 (1.94)	985 2.70 (2.01)	1005 2.80 (2.09)
4500 (2125)	665 1.45	695 1.55	725 1.65	750 1.75 (1.31)	780 1.90 (1.42)	805 2.00 (1.49)	830 2.10 (1.57)	855 2.20 (1.64)	880 2.30 (1.72)	905 2.40 (1.79)	925 2.50 (1.87)	950 2.60 (1.94)	970 2.70 (2.01)	995 2.85 (2.13)	1015 2.95 (2.20)
4600 (2170)	675 1.50	705 1.65	735 1.75 (1.31)	760 1.85 (1.38)	790 1.95 (1.45)	815 2.10 (1.57)	840 2.20 (1.64)	865 2.30 (1.72)	890 2.40 (1.79)	910 2.50 (1.87)	935 2.60 (1.94)	960 2.75 (2.05)	980 2.85 (2.13)	1000 2.95 (2.20)	1020 3.05 (2.28)
4700 (2220)	690 1.65	715 1.70	745 1.85 (1.38)	775 1.95 (1.45)	800 2.10 (1.57)	825 2.20 (1.64)	850 2.30 (1.72)	875 2.40 (1.79)	900 2.55 (1.90)	920 2.60 (1.94)	945 2.75 (2.05)	965 2.85 (2.13)	990 2.95 (2.20)	1010 3.05 (2.28)	1030 3.20 (2.39)
4800 (2265)	700 1.70	730 1.85	755 1.95 (1.45)	785 2.05 (1.53)	810 2.20 (1.64)	835 2.30 (1.72)	860 2.40 (1.79)	885 2.55 (1.90)	905 2.60 (1.94)	930 2.75 (2.05)	955 2.85 (2.13)	975 3.00 (2.24)	995 3.10 (2.31)	1015 3.20 (2.39)	1040 3.30 (2.46)
4900 (2310)	710 1.80	740 1.95 (1.45)	770 2.05 (1.53)	795 2.15 (1.60)	820 2.30 (1.72)	845 2.40 (1.79)	870 2.50 (1.87)	895 2.65 (1.98)	915 2.75 (2.05)	940 2.85 (2.13)	960 3.00 (2.24)	985 3.10 (2.31)	1005 3.20 (2.39)	1025 3.35 (2.50)	1045 3.45 (2.57)
5000 (2360)	725 1.90	755 2.05 (1.53)	780 2.15 (1.60)	805 2.30 (1.72)	830 2.40 (1.79)	855 2.50 (1.87)	880 2.65 (1.98)	905 2.75 (2.05)	925 2.85 (2.13)	950 3.00 (2.24)	970 3.10 (2.31)	990 3.20 (2.39)	1015 3.35 (2.50)	1035 3.45 (2.57)	1055 3.60 (2.69)
5100 (2405)	735 2.00 (1.49)	765 2.15 (1.60)	790 2.25 (1.68)	815 2.40 (1.79)	840 2.50 (1.87)	865 2.65 (1.98)	890 2.75 (2.05)	915 2.90 (2.16)	935 3.00 (2.24)	960 3.15 (2.35)	980 3.25 (2.42)	1000 3.35 (2.50)	1020 3.50 (2.61)	1040 3.60 (2.69)	1060 3.70 (2.76)
5200 (2455)	750 2.15 (1.60)	775 2.25 (1.68)	800 2.40 (1.79)	830 2.55 (1.90)	850 2.65 (1.98)	875 2.75 (2.05)	900 2.90 (2.16)	925 3.05 (2.28)	945 3.15 (2.35)	965 3.25 (2.42)	990 3.40 (2.54)	1010 3.50 (2.61)	1030 3.65 (2.72)	1050 3.75 (2.80)	1070 3.85 (2.87)
5300 (2500)	760 2.25 (1.68)	790 2.40 (1.79)	815 2.50 (1.87)	840 2.65 (1.98)	865 2.80 (2.09)	885 2.90 (2.16)	910 3.00 (2.24)	935 3.15 (2.35)	955 3.25 (2.42)	975 3.40 (2.54)	1000 3.55 (2.65)	1020 3.65 (2.72)	1040 3.80 (2.83)	1060 3.90 (2.91)	1080 4.05 (3.02)
5400 (2550)	775 2.40 (1.79)	800 2.50 (1.87)	825 2.65 (1.98)	850 2.75 (2.05)	875 2.90 (2.16)	895 3.00 (2.24)	920 3.15 (2.35)	945 3.30 (2.46)	965 3.40 (2.54)	985 3.55 (2.65)	1010 3.70 (2.76)	1030 3.80 (2.83)	1050 3.95 (2.95)	1070 4.05 (3.02)	1090 4.20 (3.13)
5500 (2595)	785 2.50 (1.87)	810 2.60 (1.94)	835 2.75 (2.05)	860 2.90 (2.16)	885 3.05 (2.28)	910 3.15 (2.35)	930 3.30 (2.46)	955 3.45 (2.57)	975 3.55 (2.65)	995 3.70 (2.76)	1015 3.80 (2.83)	1035 3.95 (2.95)	1055 4.05 (3.02)	1075 4.20 (3.13)	1095 4.35 (3.25)
5600 (2645)	800 2.65 (1.98)	825 2.75 (2.05)	850 2.90 (2.16)	875 3.05 (2.28)	895 3.15 (2.35)	920 3.30 (2.46)	940 3.45 (2.57)	965 3.60 (2.69)	985 3.70 (2.76)	1005 3.85 (2.87)	1025 3.95 (2.95)	1045 4.10 (3.06)	1065 4.25 (3.17)	1085 4.35 (3.25)	1105 4.50 (3.36)
5700 (2690)	810 2.75 (2.05)	835 2.90 (2.16)	860 3.05 (2.28)	885 3.20 (2.39)	905 3.30 (2.46)	930 3.45 (2.57)	950 3.55 (2.65)	975 3.75 (2.80)	995 3.85 (2.87)	1015 4.00 (2.98)	1035 4.10 (3.06)	1055 4.25 (3.17)	1075 4.40 (3.28)	1095 4.55 (3.39)	1115 4.65 (3.47)
5800 (2735)	825 2.90 (2.16)	850 3.05 (2.28)	870 3.15 (2.35)	895 3.30 (2.46)	920 3.45 (2.57)	940 3.60 (2.69)	960 3.70 (2.76)	985 3.90 (2.91)	1005 4.00 (2.98)	1025 4.15 (3.10)	1045 4.30 (3.21)	1065 4.45 (3.32)	1085 4.55 (3.39)	1105 4.70 (3.51)	1125 4.85 (3.62)
5900 (2785)	835 3.05 (2.28)	860 3.20 (2.39)	885 3.35 (2.50)	905 3.45 (2.57)	930 3.60 (2.69)	950 3.75 (2.80)	975 3.90 (2.91)	995 4.05 (3.02)	1015 4.20 (3.13)	1035 4.30 (3.21)	1055 4.45 (3.32)	1075 4.60 (3.43)	1095 4.75 (3.54)	1115 4.90 (3.66)	1130 5.00 (3.73)
6000 (2830)	850 3.20 (2.39)	870 3.30 (2.46)	895 3.45 (2.57)	920 3.65 (2.72)	940 3.75 (2.80)	960 3.90 (2.91)	985 4.05 (3.02)	1005 4.20 (3.13)	1025 4.35 (3.25)	1045 4.50 (3.36)	1065 4.65 (3.47)	1085 4.80 (3.58)	1105 4.95 (3.69)	1125 5.10 (3.80)	1140 5.20 (3.88)

NOTE — All data is measured external to the unit with dry coil and with the air filters in place. See Page 9 for Accessory Air Resistance data.

NOTE — In Canada, maximum usable motor output is 3 hp (2.24 kW).

BLOWER DATA

ACCESSORY AIR RESISTANCE									
Unit Model No.	Air Volume		Total Resistance - inches water gauge (Pa)						
			Wet Evaporator Coil	REMD16M Down-Flow Economizer	EMDH16M Horizontal Economizer	RTD11 Step-Down Diffuser			FD11 Flush Diffuser
	cfm	L/s				2 Ends Open	1 Side 2 Ends Open	All Ends & Sides Open	
GCS16-072 GCS16-090	2000	945	0.10 (25)	0.11 (27)	0.02 (5)	0.15 (37)	0.12 (30)	0.11 (27)	0.08 (20)
	2200	1040	0.11 (27)	0.15 (37)	0.03 (7)	0.18 (45)	0.15 (37)	0.13 (32)	0.11 (27)
	2400	1185	0.12 (30)	0.19 (47)	0.03 (7)	0.21 (52)	0.18 (45)	0.15 (37)	0.14 (35)
	2600	1225	0.13 (32)	0.23 (57)	0.04 (10)	0.24 (60)	0.21 (52)	0.18 (45)	0.17 (42)
	2800	1320	0.14 (35)	0.27 (67)	0.04 (10)	0.27 (67)	0.24 (60)	0.21 (52)	0.20 (50)
	3000	1415	0.16 (40)	0.31 (77)	0.05 (12)	0.32 (80)	0.29 (72)	0.25 (62)	0.25 (62)
	3200	1510	0.18 (45)	0.35 (87)	0.05 (12)	0.41 (102)	0.37 (92)	0.32 (80)	0.31 (77)
	3400	1605	0.19 (47)	0.41 (102)	0.06 (15)	0.50 (124)	0.45 (112)	0.39 (97)	0.37 (92)
	3600	1700	0.21 (52)	0.47 (117)	0.06 (15)	0.61 (152)	0.54 (134)	0.48 (119)	0.44 (109)
GCS16-120	3600	1700	0.12 (30)	0.14 (35)	0.03 (7)	0.36 (90)	0.28 (70)	0.23 (57)	0.15 (37)
	3800	1795	0.13 (32)	0.15 (37)	0.04 (10)	0.40 (99)	0.32 (80)	0.26 (65)	0.18 (45)
	4000	1890	0.14 (35)	0.16 (40)	0.04 (10)	0.44 (109)	0.36 (90)	0.29 (72)	0.21 (52)
	4200	1980	0.15 (37)	0.17 (42)	0.05 (12)	0.49 (122)	0.40 (99)	0.33 (82)	0.24 (60)
	4400	2075	0.16 (40)	0.18 (45)	0.05 (12)	0.54 (134)	0.44 (109)	0.37 (92)	0.27 (67)
	4600	2170	0.17 (42)	0.20 (50)	0.06 (15)	0.60 (149)	0.49 (122)	0.42 (104)	0.31 (77)
	4800	2265	0.18 (45)	0.22 (55)	0.07 (17)	0.65 (162)	0.53 (132)	0.46 (114)	0.35 (87)
	5000	2360	0.19 (47)	0.24 (60)	0.09 (22)	0.69 (172)	0.58 (144)	0.50 (124)	0.39 (97)
GCS16-150	5200	2455	0.20 (50)	0.27 (67)	0.10 (25)	0.75 (186)	0.62 (154)	0.54 (134)	0.43 (107)
	4200	1980	0.17 (42)	0.18 (45)	0.06 (15)	0.49 (122)	0.40 (99)	0.33 (82)	0.24 (60)
	4400	2075	0.18 (45)	0.20 (50)	0.07 (17)	0.54 (134)	0.44 (109)	0.37 (92)	0.27 (67)
	4600	2170	0.20 (50)	0.21 (52)	0.07 (17)	0.60 (149)	0.49 (122)	0.42 (104)	0.31 (77)
	4800	2265	0.21 (52)	0.23 (57)	0.08 (20)	0.65 (162)	0.53 (132)	0.46 (114)	0.35 (87)
	5000	2360	0.22 (55)	0.26 (65)	0.08 (20)	0.69 (172)	0.58 (144)	0.50 (124)	0.39 (97)
	5200	2455	0.24 (60)	0.31 (77)	0.09 (22)	0.75 (186)	0.62 (154)	0.54 (134)	0.43 (107)
	5400	2550	0.25 (62)	0.34 (85)	0.10 (25)	0.82 (203)	0.68 (169)	0.56 (139)	0.47 (117)
5600	2640	0.26 (65)	0.38 (94)	0.12 (30)	0.88 (219)	0.73 (181)	0.64 (159)	0.52 (129)	
5800	2735	0.28 (70)	0.40 (99)	0.13 (32)	0.97 (241)	0.79 (196)	0.69 (171)	0.58 (144)	

CEILING DIFFUSER AIR THROW DATA						
Model No.	Air Volume		Effective Throw Range			
			RTD11 Step-Down		FD11 Flush	
	cfm	L/s	ft.	m	ft.	m
GCS16-072 GCS16-090	2625	1240	24 - 29	7 - 9	22 - 26	7 - 8
	3000	1415	27 - 33	8 - 10	25 - 30	8 - 9
	3375	1595	30 - 37	9 - 11	28 - 34	9 - 10
	3750	1770	34 - 41	10 - 12	31 - 38	9 - 12
GCS16-120	4400	2075	34 - 42	10 - 13	32 - 40	10 - 12
	4950	2335	38 - 47	12 - 14	36 - 45	11 - 14
	5500	2595	43 - 52	13 - 16	40 - 50	12 - 15
GCS16-150	4200	1980	39 - 46	12 - 14	40 - 48	12 - 15
	5000	2360	41 - 50	12 - 15	43 - 52	13 - 16
	5800	2735	43 - 52	13 - 16	45 - 54	14 - 16

Effective Throw Range is the horizontal or vertical distance an airstream travels on leaving the outlet or diffuser before the maximum velocity is reduced to 50 ft. (15 m) per minute. Four sides open.

OPTIONAL ACCESSORIES

Item		GCS/CHA16-072	GCS/CHA16-090
Bottom Power Entry		LB-55757CA (34G70) - 12 lbs. (5 kg)	
Coil Guard - PVC coated steel wire guards to protect outdoor coil. Not used with Hail Guards.		60L31	
Control Systems		See Optional Temperature Controls Systems	
Crankcase Heaters - Ensures proper compressor lubrication at all times. Temperature actuated.	208/230 volt	67K90	90P12
	460 volt	67K89	49K11
	575 volt	42J85	49K12
Differential Enthalpy Control - For use with economizer dampers, solid-state return air sensor allows selection between outdoor air and return air (whichever has lowest enthalpy)		54G44	
Diffusers (Step-Down) - Aluminum grilles, double deflection louvers, large center grille, insulated diffuser box with flanges, hanging rings furnished, interior transition (even air flow), internally sealed (prevents recirculation), adapts to T-bar ceiling grids or plaster ceilings		RTD11-95 125 lbs. (57 kg)	
Diffusers (Flush) - Aluminum grilles, fixed blade louvers, large center grille, insulated diffuser box with flanges, hanging rings furnished, interior transition (even air flow), internally sealed (prevents recirculation), adapts to T-bar ceiling grids or plaster ceilings		FD11-95 95 lbs. (43 kg)	
Transitions (Supply and Return) - Used with diffusers, installs in roof mounting frame, galvanized steel construction, flanges furnished for duct connection, fully insulated		SRT16-09 38 lbs. (17 kg)	
Economizer Dampers (Down-Flow) - Mechanically linked recirculated air and outdoor air dampers, plug-in connections to unit, nylon bearings, stainless steel seals (outdoor dampers), 24 volt fully modulating spring return damper motor, adjustable minimum damper position switch, mixed air controller, solid-state adjustable outdoor air enthalpy control, 0 to 100% outdoor air adjustable, gravity exhaust air dampers furnished, powdered enamel paint finish NOTE - Fresh air/exhaust air hood with cleanable aluminum mesh frame filter, is required and must be ordered separately for field installation (see below)	Model No. - Net Wt.	REMD16M-09 60 lbs. (27 kg)	
	Net face area	2.1 ft. ² (0.20 m ²)	
Economizer Damper Hood (Down-flow) - For use with REMD16M economizer dampers (see above). Must be ordered separately.	Order No.	27L58	
	No. & Size of Filters	(1) 32-1/4 x 16-1/2 x 1 (819 x 419 x 25)	
Economizer Dampers (Horizontal) - Mechanically linked recirculated air and outdoor air dampers, plug-in connections to unit, nylon bearings, stainless steel seals (outdoor dampers), 24 volt fully modulating spring return damper motor, adjustable minimum damper position switch, mixed air controller, solid-state adjustable outdoor air enthalpy control, 0 to 100% outdoor air adjustable, galvanized steel cabinet, flanged air openings on return air section, powdered enamel paint finish, fully insulated. NOTE - Outdoor air hood with two cleanable aluminum mesh frame filters is required and must be ordered separately. Also requires optional Horizontal Supply and Return Air Kit for duct connection		EMDH16M-09 120 lbs. (54 kg)	
Economizer Damper Hood (Horizontal) - For use with EMDH16M economizer dampers (see above). Must be ordered separately.	Order No.	68G80	
	No. & Size of Filters	(2) 16 x 25 x 1 (406 x 635 x 25)	
Economizer Gravity Exhaust Dampers (Horizontal) - For use with EMDH16 horizontal economizer damper sections, two neoprene coated fiberglass dampers furnished, rainhoods furnished, bird screen furnished		GED16-09/12 (5 lbs.) (2 kg) Net face area - 0.43 sq. ft. (0.04 m ²) used with EMDH16M	
Hail Guards - Heavy duty field installed coil guard protects coils from damage. Not used with Coil Guards.		60L33	
Horizontal Supply and Return Air Kit - Provides duct connection to unit, flanges furnished, hardware furnished, two filler panels furnished for unused air openings, filter access panel furnished		LB-55756BA (34G71) 30 lbs. (14 kg)	
Low Ambient Controls - Allows unit operation down to 0°F (-17.7°C)		LB-57113BC (24H77)	LB-57113BG (15J80)
LPG/Propane Kits		(LB-87459H) 58L34	
Outdoor Air Damper Section - Linked mechanical dampers, interchangeable unit panel furnished (down-flow applications), two-piece cabinet (control access), cleanable polyurethane frame type filter furnished, 0 to 25% (fixed) outdoor air adjustable, manual or automatic operation (kit required for automatic operation), installs on unit for down-flow applications, installs in return air duct for horizontal applications	Model No. - Net Wt.	OAD16-09 41 lbs. (19 kg)	
	No. & Size of Filters	(1) 16 x 20 x 1 (406 x 508 x 25)	
Outdoor Air Damper Motorized Damper Kit - 3 position damper actuator, plug-in connection		35G21 - 7 lbs. (3 kg)	
Roof Mounting Frame - Nail strip furnished, mates to unit, U.S. National Roofing Contractors Approved, shipped knocked down		RMF16-09 107 lbs. (49 kg)	
Electric Heat - Factory or field installed, helix wound nichrome elements, time delay for element staging, individual element limit controls, may be two-stage controlled, requires optional Fuse Block		ECH16-82/95 10-15-20-30-40 kW (all voltages)	
Unit Fuse Block - Required for electric heat installation, wiring harness and mounting screws furnished	208/230volt	50L22 (50 amp)	
	460 volt	50L24 (25 amp)	
	575 volt	50L23 (20 amp)	

OPTIONAL ACCESSORIES

Item		GCS/CHA16-120	GCS/CHA16-150
Bottom Power Entry		LB-55757CA (34G70) - 12 lbs. (5 kg)	
Coil Guard - PVC coated steel wire guards to protect outdoor coil. Not used with Hail Guards.		60L32	
Control Systems		See Engineering Handbook	
Crankcase Heaters - Ensures proper compressor lubrication at all times. Temperature actuated.	208/230 V	67K90	
	460 V	67K89	
	575 V	42J85	
Differential Enthalpy Control - For use with economizer dampers, solid-state return air sensor allows selection between outdoor air and return air (whichever has lowest enthalpy)		54G44	
Diffusers (Step-Down) - Aluminum grilles, double deflection louvers, large center grille, insulated diffuser box with flanges, hanging rings furnished, interior transition (even air flow), internally sealed (prevents recirculation), adapts to T-bar ceiling grids or plaster ceilings		RTD11-135 205 lbs. (93 kg)	
Diffusers (Flush) - Aluminum grilles, fixed blade louvers, large center grille, insulated diffuser box with flanges, hanging rings furnished, interior transition (even air flow), internally sealed (prevents recirculation), adapts to T-bar ceiling grids or plaster ceilings		FD11-135 174 lbs. (79 kg)	
Transitions (Supply and Return) - Used with diffusers, installs in roof mounting frame, galvanized steel construction, flanges furnished for duct connection, fully insulated		SRT16-12 38 lbs. (17 kg)	
Economizer Dampers (Down-Flow) - Mechanically linked recirculated air and outdoor air dampers, plug-in connections to unit, nylon bearings, stainless steel seals (outdoor dampers), 24 volt fully modulating spring return damper motor, adjustable minimum damper position switch, mixed air controller, solid-state adjustable outdoor air enthalpy control, 0 to 100% outdoor air adjustable, gravity exhaust air dampers furnished, powdered enamel paint finish NOTE - Fresh air/exhaust air hood with cleanable aluminum mesh frame filter, is required and must be ordered separately for field installation (see below)	Model No. - Net Wt.	REMD16M-12 80 lbs. (36 kg)	REMD16M-15 100 lbs (45 kg)
	Net face area	2.8 ft. ² (0.26 m ²)	3.6 ft. ² (0.33 m ²)
Economizer Damper Hood (Down-flow) - For use with REMD16M economizer dampers (see above). Must be ordered separately.	Order No.	27L60	48L00
	No. & Size of Filters	(1) 32-1/4 x 21-1/4 x 1 (819 x 546 x 25)	(1) 40-1/4 x 21-1/2 x 1 (1022 x 546 x 25)
Economizer Dampers (Horizontal) - Mechanically linked recirculated air and outdoor air dampers, plug-in connections to unit, nylon bearings, stainless steel seals (outdoor dampers), 24 volt fully modulating spring return damper motor, adjustable minimum damper position switch, mixed air controller, solid-state adjustable outdoor air enthalpy control, 0 to 100% outdoor air adjustable, galvanized steel cabinet, flanged air openings on return air section, powdered enamel paint finish, fully insulated. NOTE - Outdoor air hood with two cleanable aluminum mesh frame filters is required and must be ordered separately. Also requires optional Horizontal Supply and Return Air Kit for duct connection		EMDH16M-12 135 lbs. (62 kg)	EMDH16M-15 187 lbs (85 kg)
Economizer Damper Hood (Horizontal) - For use with EMDH16M economizer dampers (see above). Must be ordered separately.	Order No.	68G80	68G77
	No. & Size of Filters	(2) 16 x 25 x 1 (406 x 635 x 25)	(2) 20 x 25 x 1 (508 x 635 x 25)
Economizer Gravity Exhaust Dampers (Horizontal) - For use with EMDH16 horizontal economizer damper sections, two neoprene coated fiberglass dampers furnished, rainhoods furnished, bird screen furnished		GED16-09/12 (5 lbs.) (2 kg) Net face area - 0.43 sq. ft. (0.04 m ²) used with EMDH16M	
Hail Guards - Heavy duty field installed coil guard protects coils from damage. Not used with Coil Guards.		60L34	
Horizontal Supply and Return Air Kit - Provides duct connection to unit, flanges furnished, hardware furnished, two filler panels furnished for unused air openings, filter access panel furnished		LB-55756BB (35G42) 35 lbs. (16 kg)	LB-55756BC (51G27) 39 lbs. (18 kg)
Low Ambient Controls - Allows unit operation down to 0°F (-17.7°C)		LB-57113BW (53L84)	
LPG/Propane Kits		(LB-87459H) 58L34	
Outdoor Air Damper Section - Linked mechanical dampers, interchangeable unit panel furnished (down-flow applications), two-piece cabinet (control access), cleanable polyurethane frame type filter furnished, 0 to 25% (fixed) outdoor air adjustable, manual or automatic operation (kit required for automatic operation), installs on unit for down-flow applications, installs in return air duct for horizontal applications	Model No. - Net Wt.	OAD16-12 43 lbs. (20 kg)	OAD16-15 50 lbs. (23 kg)
	No. & Size of Filters	(1) 16 x 20 x 1 (406 x 508 x 25)	(1) 16 x 20 x 1 (406 x 508 x 25)
Outdoor Air Damper Motorized Damper Kit - 3 position damper actuator, plug-in connection		35G21 - 7 lbs. (3 kg)	
Roof Mounting Frame - Nailor strip furnished, mates to unit, U.S. National Roofing Contractors Approved, shipped knocked down		RMF16-12 119 lbs. (54 kg)	
Electric Heat - Factory or field installed, helix wound nichrome elements, time delay for element staging, individual element limit controls, may be two-stage controlled, requires optional Fuse Block		ECH16-135 15-20-30-40-50 kW (all voltages)	
Unit Fuse Block - Required for electric heat installation, wiring harness and mounting screws furnished	208/230volt	50L25 (70 amp)	50L25 (70 amp)
	460 volt	50L26 (35 amp)	50L26 (35 amp)
	575 volt	50L24 (25 amp)	50L27 (30 amp)

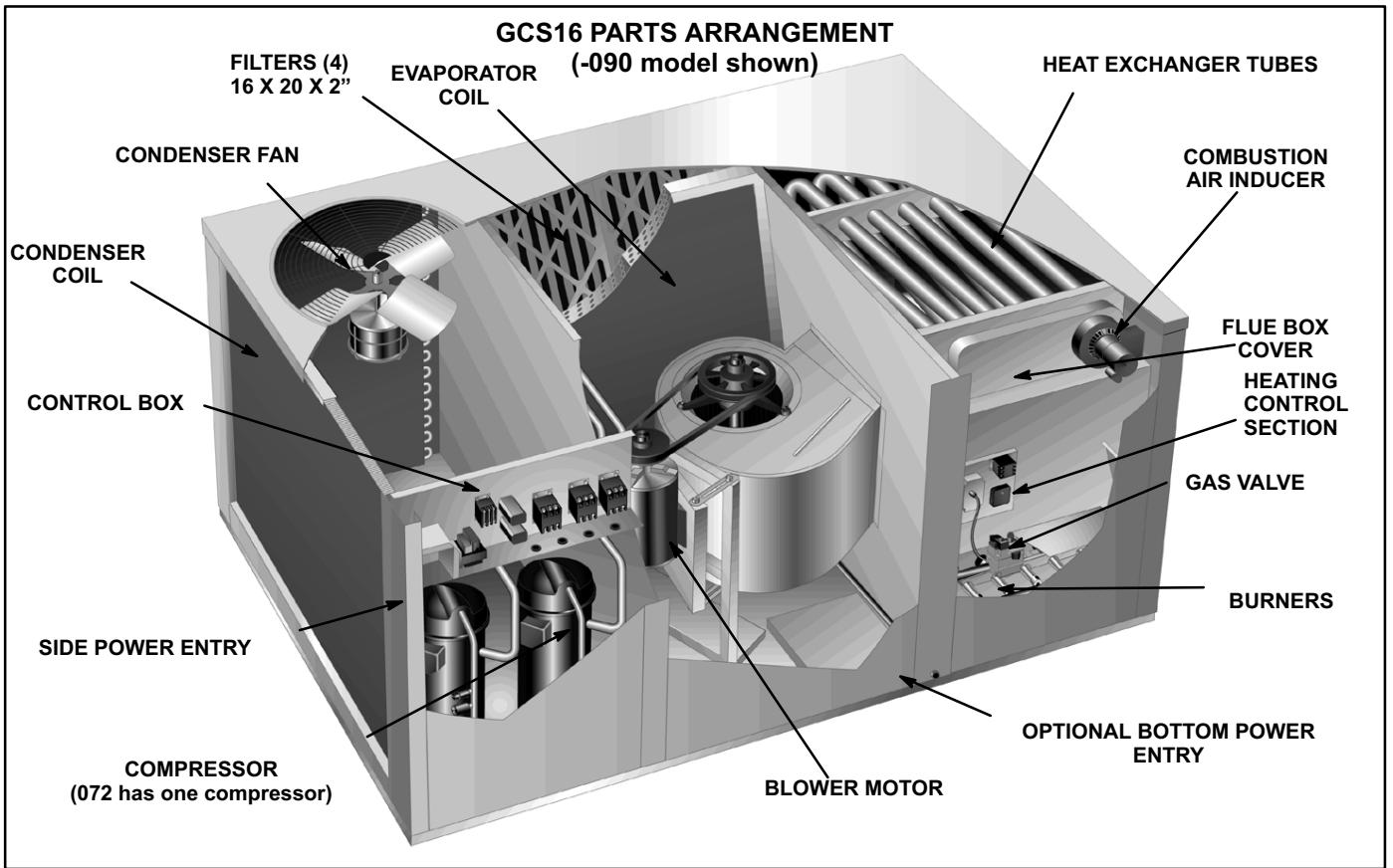

FIGURE 1

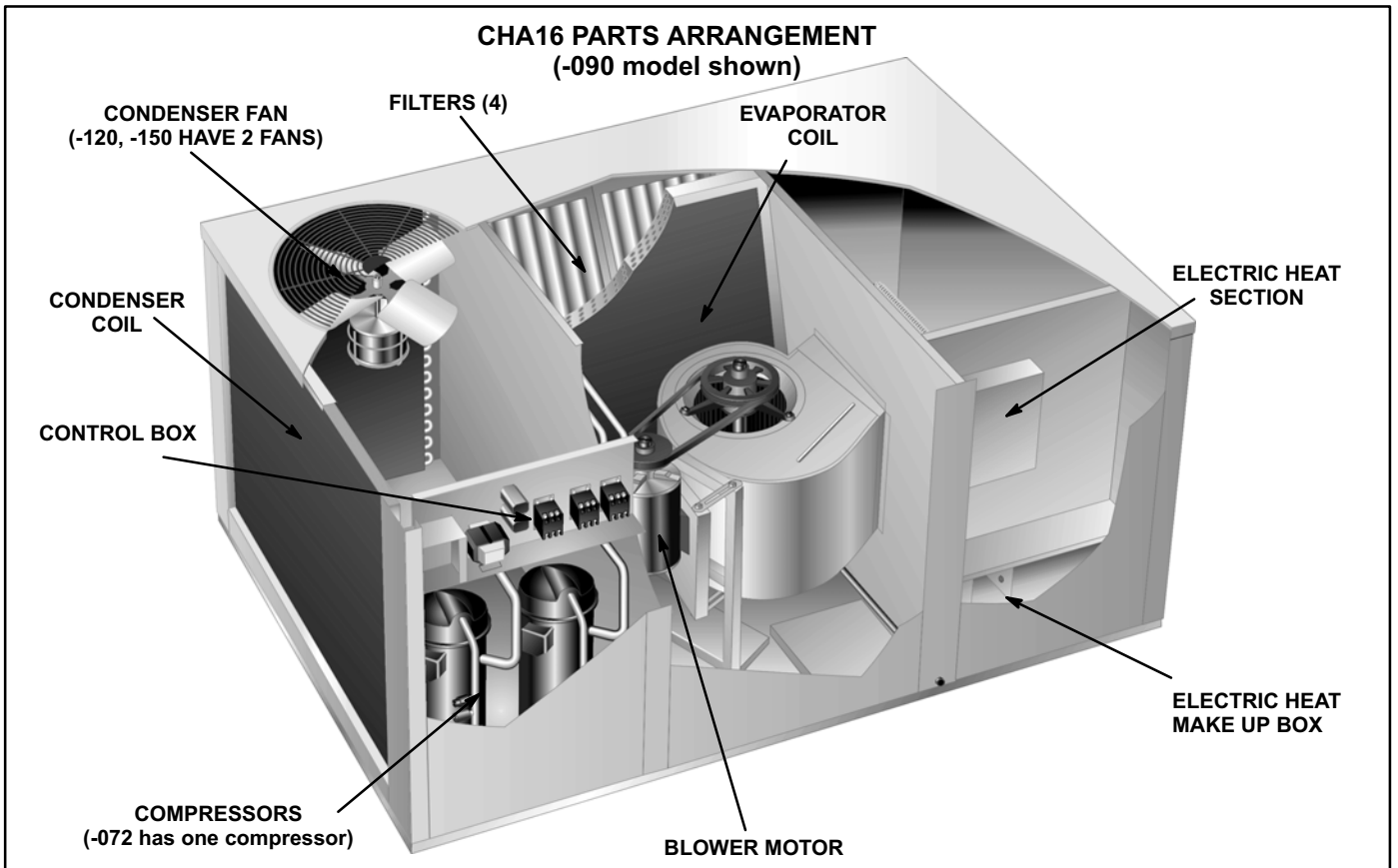
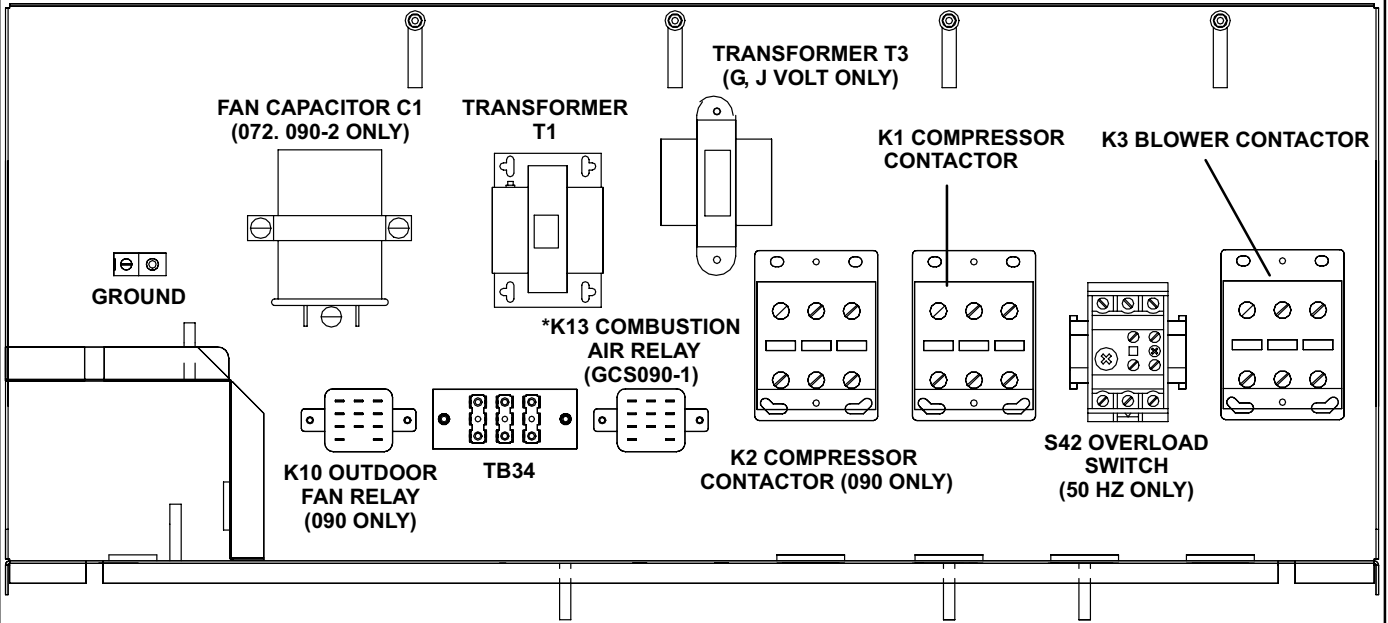

FIGURE 2

GCS/CHA16-072/090 CONTROL BOX



* K13 is located in the heat section on GCS16-072 and 090-2 units.

FIGURE 3

GCS/CHA16-120/150 CONTROL BOX

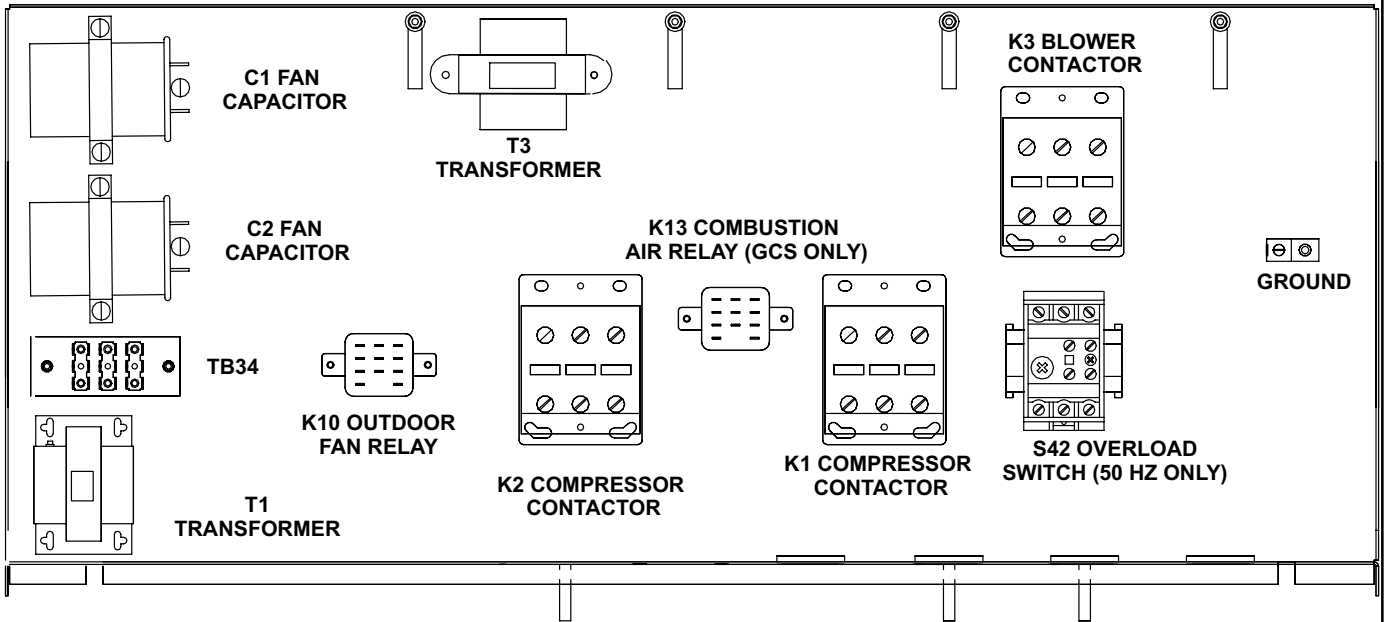

FIGURE 4

I-APPLICATION

GCS/CHA16 6 and 7.5 ton units are available in one cabinet size and GCS/CHA16 10 and 12.5 ton units are available in one size. All models are applicable for commercial three phase installations. GCS/CHA16 models are factory equipped with the hardware required for installing Lennox' optional thermostat control systems like the T7300 or T8621D (refer to the Engineering Handbook for more specific application data).

II-UNIT COMPONENTS

GCS16 unit components are shown in figure 1. CHA16 unit components are shown in figure 2.

A-Control Box Components

The GCS/CHA16 control box is shown in figures 3 and 4. The control box is located in the upper portion of the compressor compartment behind the compressor compartment access panel. Note that the burner ignition control (GCS models only) is located in the heating control section located just above the manifold /burner assembly.

The condenser fan can be accessed by removing the fan grill located on top of the unit.

The indoor blower access panel (all units) is located to the left side of the heating compartment access.

1-Transformer T1

All GCS/CHA16-072/090/120/150 units use a single line voltage to 24VAC transformer mounted in the control box. The transformer supplies power to control circuits in the unit. Transformers are rated at 70VA and is protected by a 3.5 amp circuit breaker (CB8). Transformers use two primary voltage taps as shown in figure 5. T1

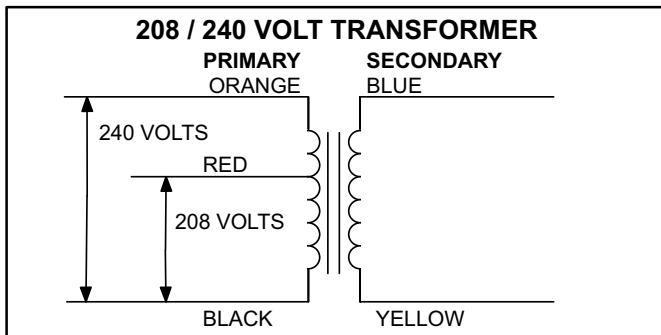

FIGURE 5

2-Terminal Strip TB34

Terminal strip TB34 distributes 24V power from transformer T1 to the control box components.

3- Transformer T3 (G & J Voltage Only)

All GCS16-072/090/120/150 G and J units use one 230VAC transformer mounted in the control box. The transformer has an output rating of 115VA .55A@ 230V. T3 transformer supplies 230VAC power to combustion air inducer motor B6.

4- Outdoor Fan Relay K10

Outdoor fan relay K10 used in GCS/CHA16-090/120/150 units, is a DPDT relay with a 24Vcoil. K10 energizes outdoor fans B4 and B5 (120/150 units) in response to thermostat demand.

5-Cooling Contactor K1 & K2

K1 and K2 are 24V coil contactors used to energize the compressor(s) in response to thermostat demand. In GCS/CHA16-072 units, K1 energizes condenser fan B4 along with compressor B1. In GCS/CHA16-090/120/150 units, K1 energizes compressor B1 and K2 energizes compressor B2 in response to second stage cooling demand. All GCS/CHA16-072/090/120/150 units use three-pole-double-break contactors.

⚠ DANGER

Remove all power to disconnect before servicing.

Electrical shock resulting in death or injury may result if power is not disconnected.

6-Indoor Blower Contactor K3

All GCS/CHA16-072/090/120/150 units use a three-pole double break contactor to energize the indoor blower and optional economizer. The coil is energized by blower demand from indoor thermostat terminal "G" (cooling demand or fan switch in "ON" position).

7-Condenser Fan Motor Capacitor C1 & C2

GCS/CHA16-072/090/120/150 series units use single-phase PSC condenser fan motors. See condenser fan motor nameplate for capacitor ratings.

B-Heat Control Section (GCS Only)

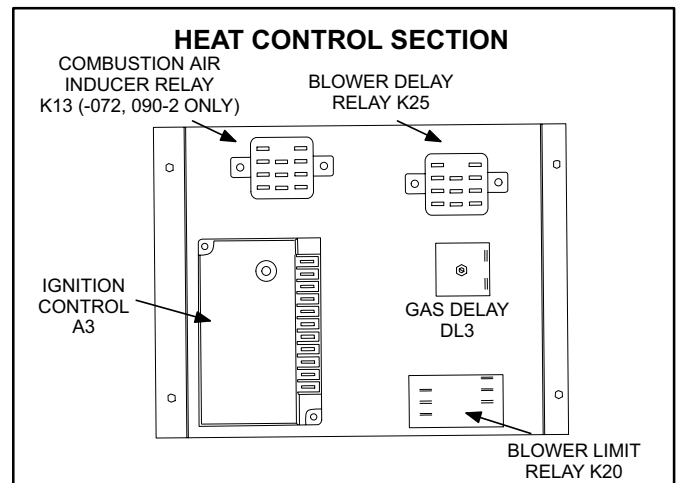

FIGURE 6

1-Ignition Control A3

⚠ DANGER

Shock Hazard.

Spark related components contain high voltage. Disconnect power before servicing unit. The ignition control is not field repairable.

Can cause unsafe operation, injury or death.

ELECTROSTATIC DISCHARGE (ESD) Precautions and Procedures

⚠ CAUTION

Electrostatic discharge can affect electronic components. Take precautions during unit installation and service to protect the electronic controls. Precautions will help to avoid control exposure to electrostatic discharge by putting the unit, the control and the technician at the same electrostatic potential. Neutralize electrostatic charge by touching hand and all tools on an unpainted unit surface, such as the gas valve or blower deck, before performing any service procedure.

ALL GCS16-090-1 model units and GCS16120/150 units will be equipped with a Fenwal ignition control. See figure 7. GCS16-072 and GCS16-090-2 model units will be equipped with a Johnson control. See figure 8. The ignition control provides three main functions: gas valve control, ignition, and flame sensing. The unit will usually ignite on the first attempt; however, the ignition attempt sequence provides three trials for ignition before locking out. After 5 minutes, the ignition control automatically resets and provides three more attempts at ignition. Manual reset after lockout requires breaking and remaking power to the ignition control. See figure 9 (Fenwal control) or figure 10 (Johnson control) for ignition sequence with retries timings.

Flame rectification sensing is used on all GCS16 units. Loss of flame during a heating cycle is indicated by an absence of flame signal. If this happens, the control will immediately restart the ignition sequence and then lock out if ignition is not gained after the third trial. See table 1 for microamp signal value.

The ignition control shuts off gas flow immediately in the event of a power failure. Upon restoration of gas and power, the control will restart the ignition sequence and continue until flame is established or system locks out.

On a heating demand, the the combustion air inducer is energized. As the combustion air inducer nears full speed, the combustion air prove switch S18 closes energizing ignition control A3. The ignition control then has a 30 to 40 second delay to allow the combustion air inducer to purge exhaust gases from the combustion chamber and introduce fresh air. After the delay, the ignition control then activates gas valve, the spark electrode and the flame sensing electrode. Sparking stops immediately after flame is sensed. The combustion air inducer continues to operate throughout the heating demand. If the flame fails or if the burners do not ignite, the ignition control will attempt to ignite the burners up to two more times. If ignition cannot be obtained after the third attempt, the control will lock out. The ignition control is not adjustable.

The Johnson control is illustrated in figure 8. The spade connections are used to connect the control to unit. Each of the spade terminals are identified by function. The spark electrode wire connects to the spark-plug-type connector on top of the control.

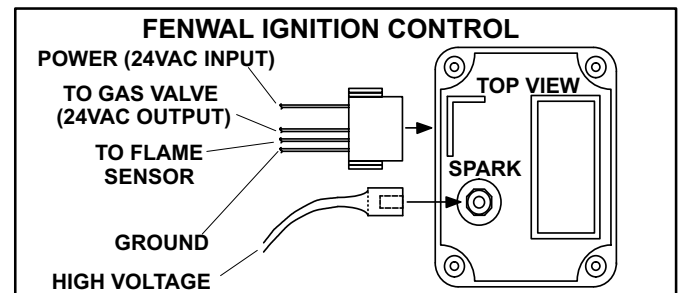

FIGURE 7

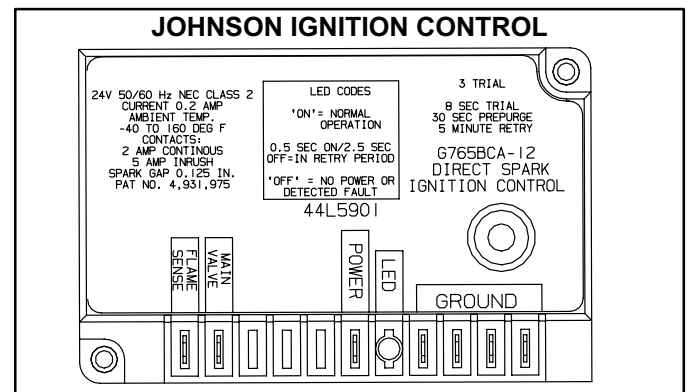

FIGURE 8

TABLE 1

Manufacturer	Nominal Signal Microamps	Drop Out
JOHNSON	0.5-1.0	.09
FENWALL	8-20	3

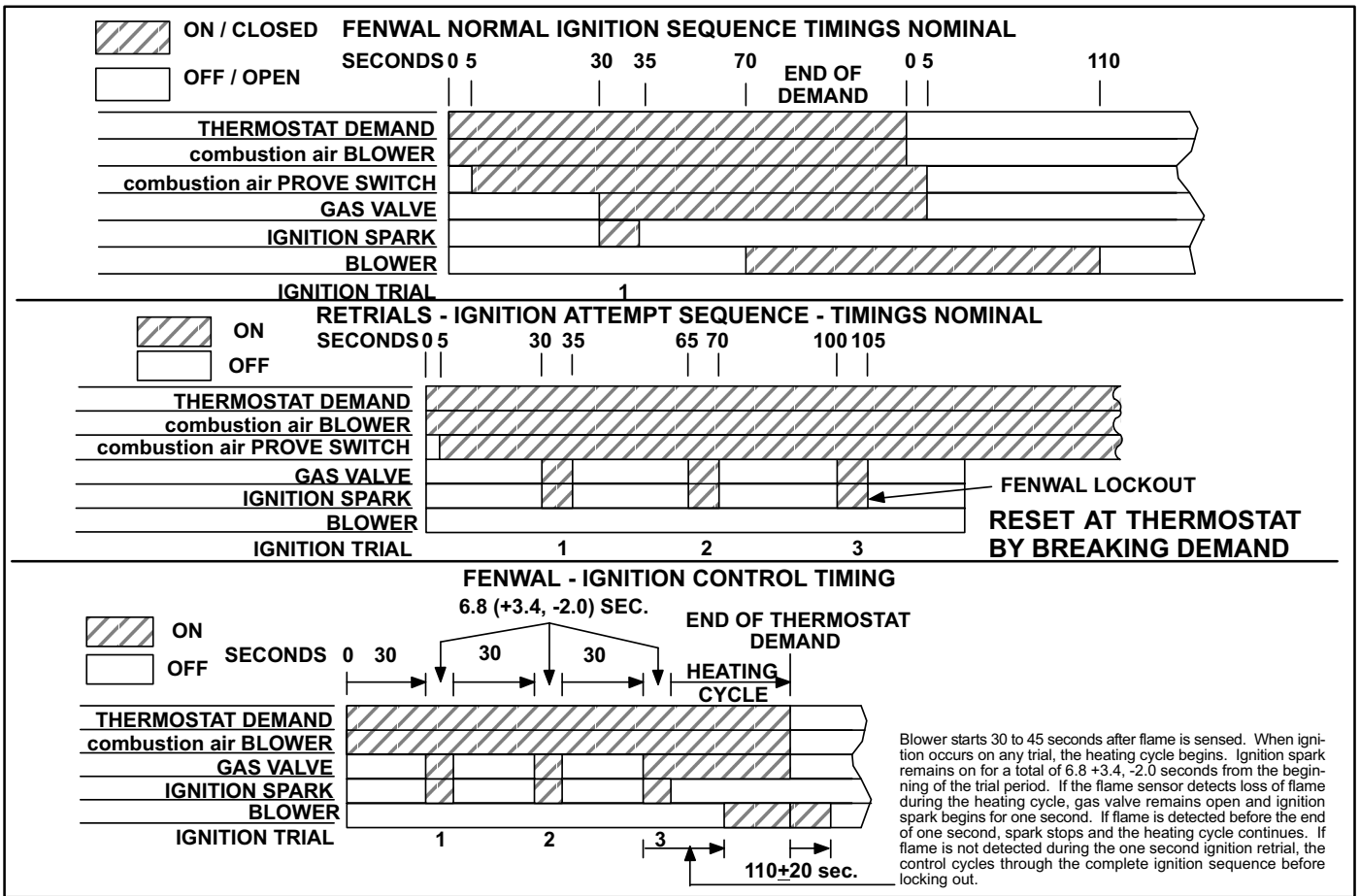

FIGURE 9

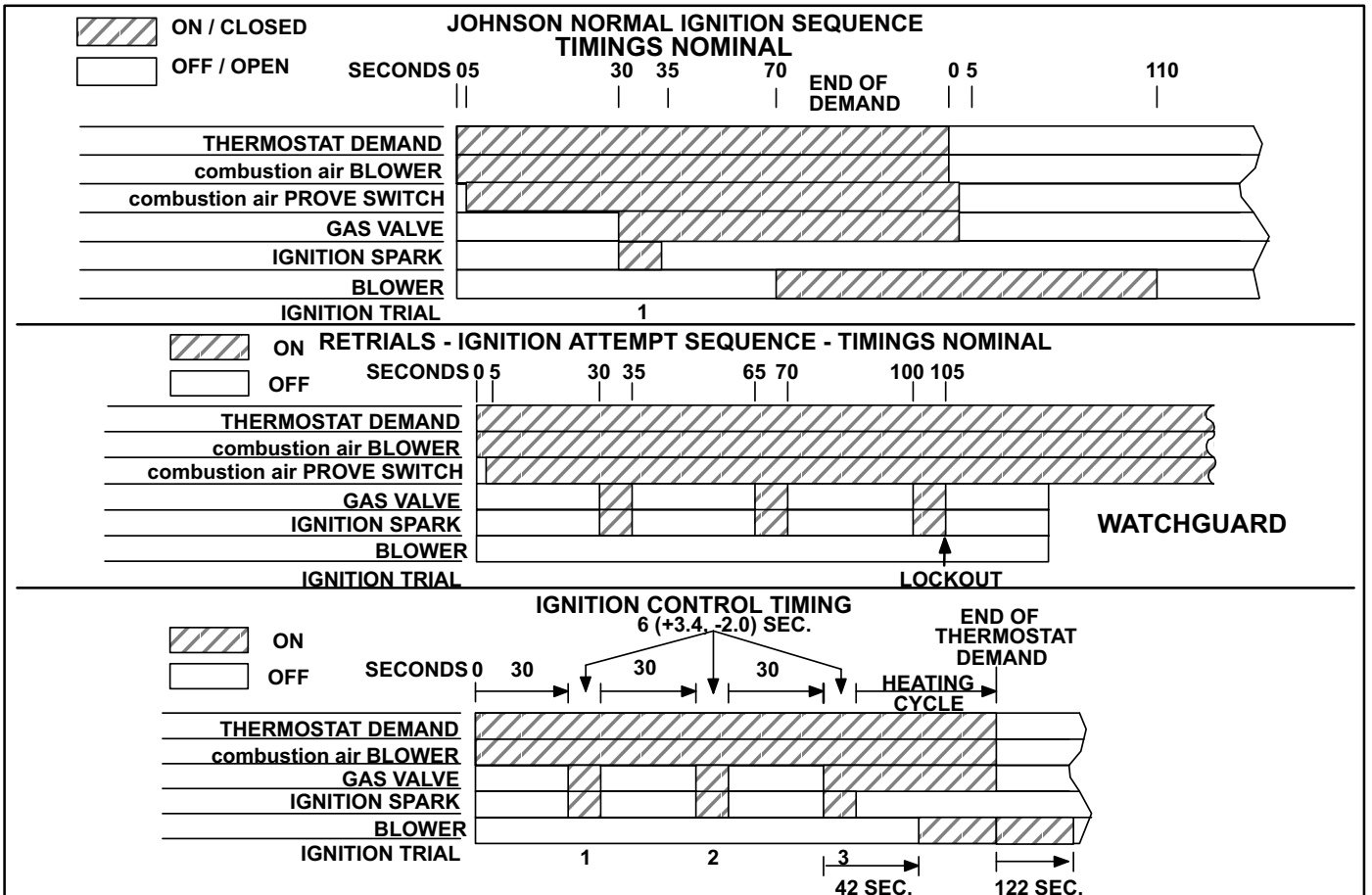

FIGURE 10

2-Combustion Air Inducer Relay K13

Relay K13 is a DPDT relay. Location is as follows: 072 and 090-2 models in the heat control section, 090-1 and 120/150 models in the control box. K13 is energized by heating demand from the thermostat and is energized throughout the heating demand. When energized, K13 normally open contacts close to energize the combustion air inducer and begin a heating sequence.

3- Indoor Blower Delay Relay K25

Relay K25 is a printed circuit board located in the heating control section wired in series with the gas valve. K25 is designed to provide an indoor blower delay of 45 seconds on time and 150 seconds off time during a heat demand. When there is a demand for heat, the gas valve will open and the on time delay will begin. When heat demand is satisfied the gas valve will close and the off time will begin.

4- Indoor Blower Limit Relay K20

Relay K20 is a DPDT relay located in the control box on GCS16-090-1 models and in the heating control section for GCS16-072, GCS16-090-2 and 120/150 models. Relay K20 is wired in series with limit S10 and S21. If either limit opens, K20-1 contacts close energizing blower contactor K3. Simultaneously, K20-2 contacts open de-energizing the gas valve.

5- Gas Delay DL3 (stage 2 delay)

Time delay DL3 is located in the heating control section. Upon receiving increased heat demand, DL3 initiates a 180 second time delay before closing its N.O. contacts. After the delay, DL3 energizes W2 on the gas valve bringing on 2nd. stage heat. DL3 is wired in series with the gas valve and indoor blower limit relay K20.

C-Heating Components

1-Heat Exchanger (Figures 11 and 12)

All GCS units use an aluminized steel tubular heat exchanger. Each tube has a matching inshot burner. Combustion takes place at each tube entrance and is drawn upwards through each tube by the combustion air blower. Heat is transferred from all surfaces of the heat exchanger tubes. The supply air blower, controlled by the ignition control, forces air across all surfaces of the tubes to extract the heat of the combustion. The shape of the tubes ensure maximum heat exchange.

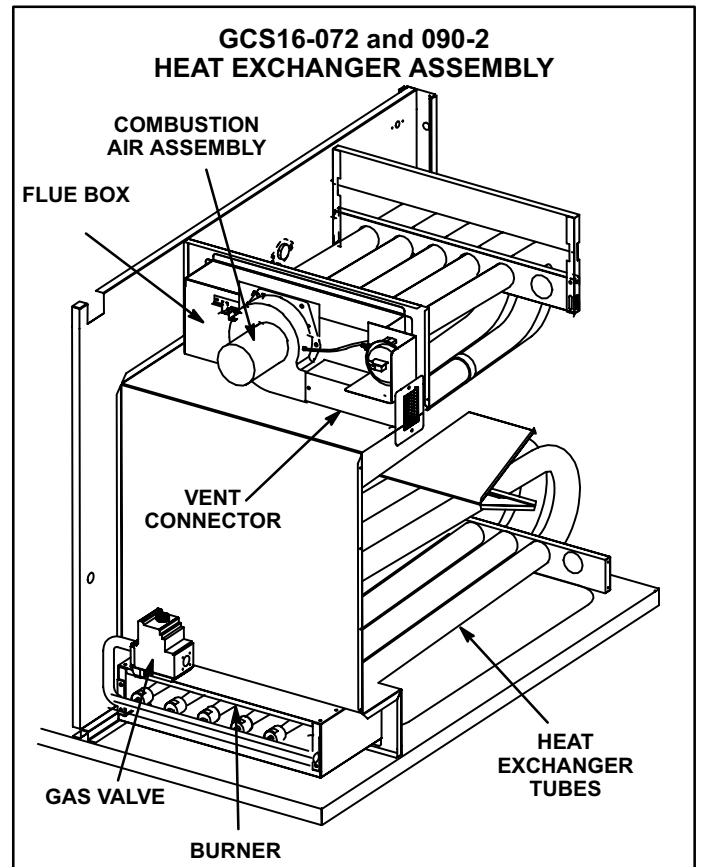

FIGURE 11

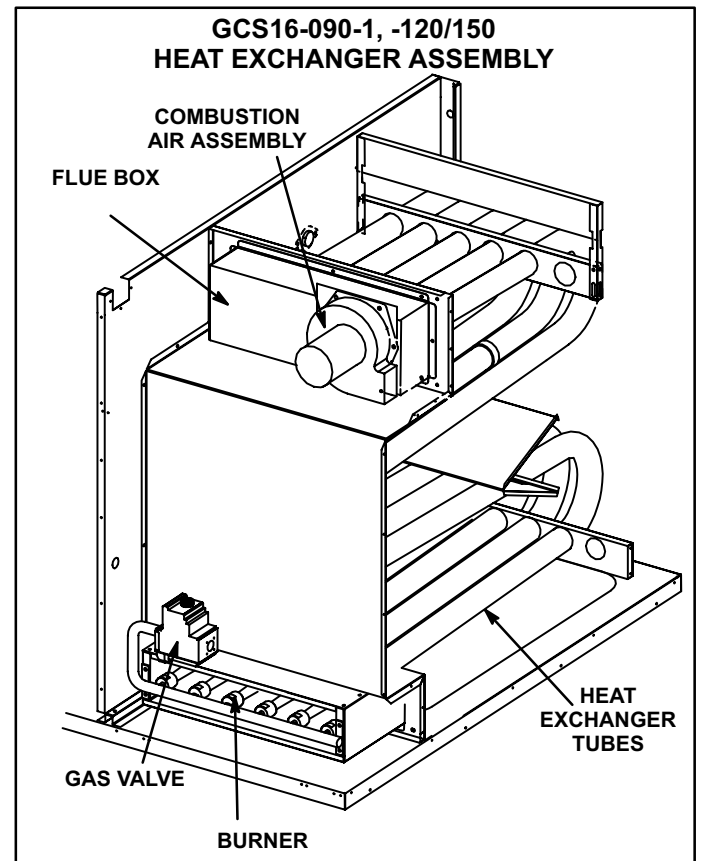

FIGURE 12

2-Burner Assembly (Figure 13)

The burners are controlled by the spark electrode, flame sensing electrode, gas valve GV1 and combustion air blower B6. The spark electrode, flame sensing electrode and gas valve GV1 are directly controlled by ignition control A3.

a-Burners

All units use inshot burners. Burners are factory set and do not require adjustment. Burner shutters are designed to be fully open only. Units are furnished with a peep hole with cover in the access panel for flame viewing. Always operate unit with access panel in place. Burners can be individually removed for service. Burner maintenance and service is detailed in the MAINTENANCE section of this manual.

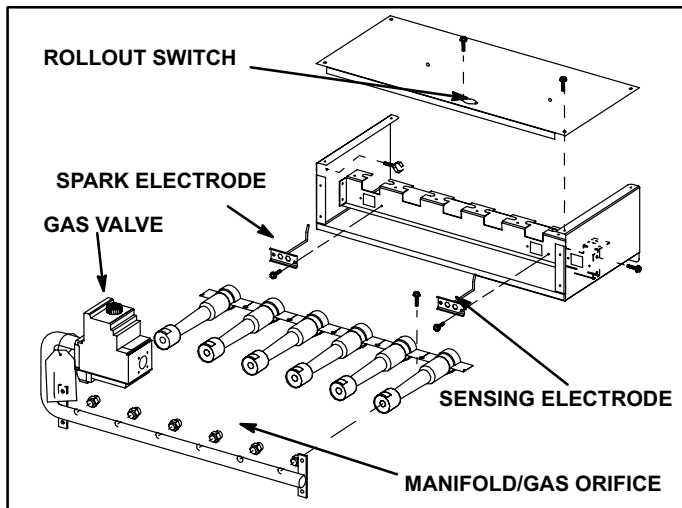

FIGURE

b-Orifice

Each burner uses an orifice which is matched to the burner input. The orifice is threaded into the manifold. The burner is supported by the orifice and will easily slide off for service.

Each orifice and burner are sized specifically to the unit. Refer to Lennox Repair Parts for correct sizing.

3-Flame Rollout Switch S47 (figure 14)

Flame rollout switch S47 is a high temperature limit located just above the burner on all units. See figure 13. The limit is a N.C. SPST manual re-set thermostat connected in series with ignition control A3. When S47 senses flame rollout, ignition control immediately closes the gas valve. The switch is factory set to open at 180° and cannot be adjusted.

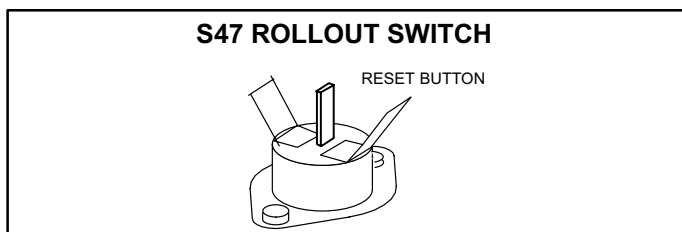

FIGURE 14

4-Primary High Temperature Limit S10

S10 is the primary limit for gas heat. See figure 15 for both types used. On GCS16-090-1 model units, S10 is located in the heating compartment and mounted to the lower portion of the panel dividing the heating compartment from the blower compartment. On GCS16-072 and GCS16-090-2 models, S10 is located in the return air area. On GCS16-120/150 models, S10 is located in the blower compartment. Primary limit S10 is wired in series with the burner control A3. S10 N.C. contacts open to de-energize the ignition control when excessive heat is reached in the heat exchanger. At the same time, the N.O. contacts close energizing K20 blower limit relay, which in turn energizes the blower relay K3 energizing indoor blower B3. See table 2 for factory set point. Stick type limit used on GCS16-072 and 090-2 models must be installed with limit face in DOWN position.

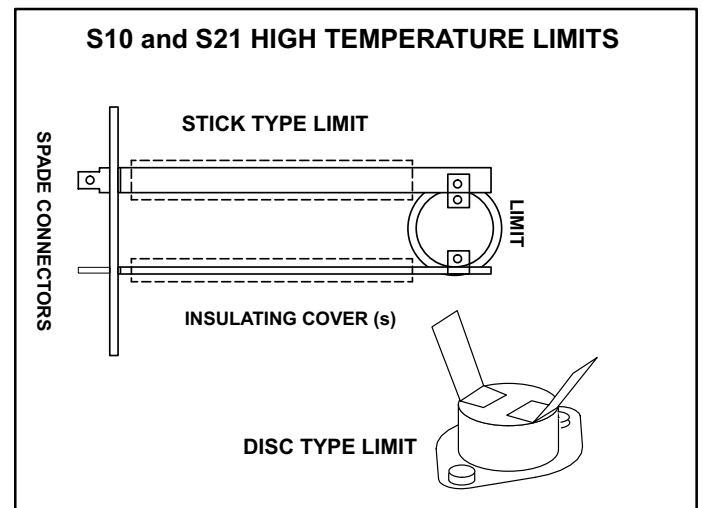

FIGURE 15

TABLE 2

GCS16 Unit	S10 Set Point°	S21 Set Point°
072-1	200	175
090-1	180	150
090-2	200	175
120-1	180	150
120-2	170	150
150-1	170	150

5-Secondary Limit S21

All GCS16 model units are equipped with a secondary limit (disc type limit figure 15). On GCS16-072/090 models, S21 is located in the blower compartment. On GCS16-120/150 models, S21 is located in the return air (behind filters). The limit is an auto-re-set thermostat which opens on temperature rise. S21 is wired in series with the ignition control. The limit is used to de-energize the ignition control and shut down the unit when temperature in the blower compartment becomes too high. The limit is factory set and is not adjustable. See table 2. This is a safety shutoff function of this unit and must never be by-passed.

6-Combustion Air Prove Switch S18

GCS16-072 and GCS16-090-2 MODEL UNITS

The combustion air prove switch (S18) is a SPST N.O. differential pressure switch used to monitor combustion air inducer operation. A flexible hose connects one side of the switch to the blower housing. The other side of the switch is open to the atmosphere. See figure 11. The switch is wired in series with ignition control A3. Prove switch S18 closes when combustion air inducer reaches full speed to allow the ignition control to energize. This proves that the combustion air inducer is operating and allows the heating cycle to continue.

Combustion air prove switch S18 is factory set and non-adjustable. Set point will be on the side of switch.

GCS16-090-1 GCS16-120/150 MODEL UNITS

Combustion air prove switch S18 is a SPST N.O. centrifugal switch inside the combustion air motor. It is used to monitor combustion air inducer operation. The switch is wired in series with ignition control A3. On start up, the switch closes when the combustion air motor reaches a set speed (1800 - 2500 RPM) to allow power to the ignition control (proves, by closing, that the combustion air inducer is operating before allowing the ignition control to be energized).

7-Combustion Air Inducer B6

Combustion air inducer B6 provides fresh air to the burner while clearing the combustion chamber of exhaust gases. The inducer uses a PSC, 208/230VAC, single phase, 1/25 hp motor. The inducer begins operating immediately upon receiving a thermostat demand and is de-energized immediately when thermostat demand is satisfied. However, at colder ambients down to -40°F, the blower may take up to 15 seconds before rotation begins. All combustion air inducer motors are sealed and cannot be oiled.

GCS16-072 and GCS16-090-2 MODEL UNITS

The tube connecting S18 to the inducer housing must be sloped in a manner that will prevent condensate from collecting in the tube. See figure 16. It is normal for a small amount of condensate to form in the tube during unit operation. The tube and switch must be allowed to drain accumulated condensate between thermostat demands. If the tube is positioned so that accumulated condensate is trapped in the tube, the unit may run improperly or may lock out.

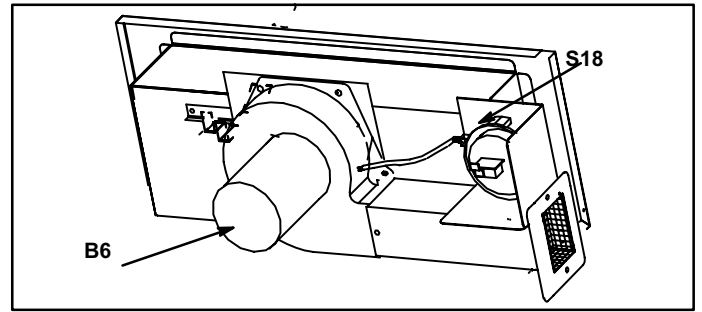

FIGURE 16

8-Flue Vent (Figure 17)

⚠ IMPORTANT

Vent cap assembly must be installed without modification. Any modification to the vent cap assembly or failure to install assembly can result in improper operation and will void the AGA/CGA certification of the unit.

⚠ CAUTION

Do not start or operate unit unless vent cap is in place.

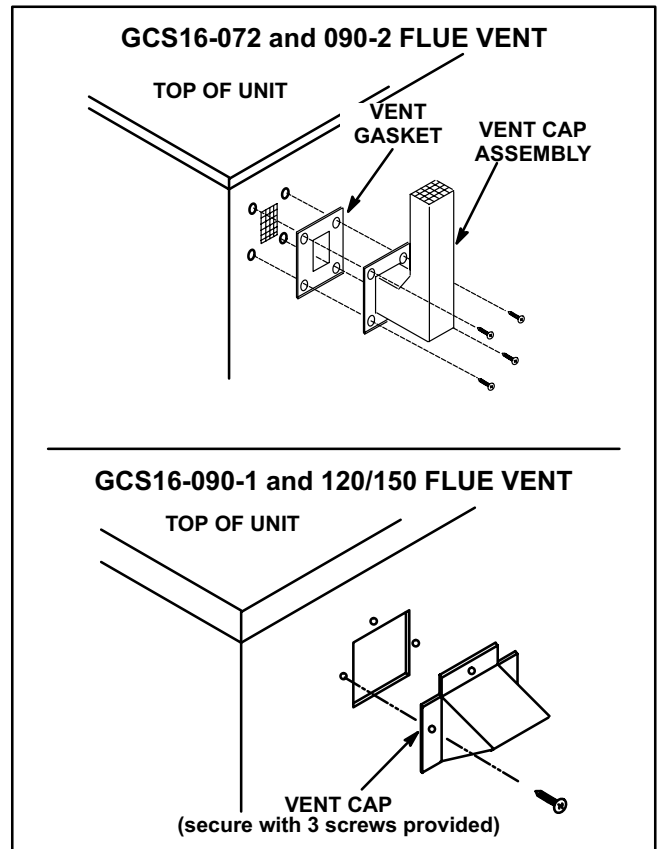

FIGURE 17

9-Gas Valve GV1 (Figure 18)

Gas valve GV1 is a two-stage redundant gas valve used in all GCS16 units. Units are equipped with valves manufactured by White-Rodgers or Honeywell. The White-Rodgers first stage (low fire) is quick opening (on and off in less than 3 seconds). Second stage (high fire) is slow opening (on in 40 seconds off in 30 seconds). The White-Rodgers valve is adjustable on high fire only. The Honeywell valve first stage (low fire) AND second stage (high fire) is quick opening (on and off in less than 3 seconds) and can be adjusted on both, first and second stage. On a call for first stage heat (low fire), the valve is energized by the ignition control simultaneously with spark electrode. On a call for second stage heat (W2) timer DL3 energizes W2 on the valve after a 3 minute delay. See table 3 for gas valve manifold range. A manual shut off knob is provided on the valve for shut off. The knob immediately closes both stages without delay.

TABLE 3
Manifold Pressure Range

Valve Stage	Nat" W.C.	L.P." W.C.
Low Fire	1.6 ± 0.2	5.5 ± 0.3
High Fire	3.7 ± 0.3	10.5 ± 0.5

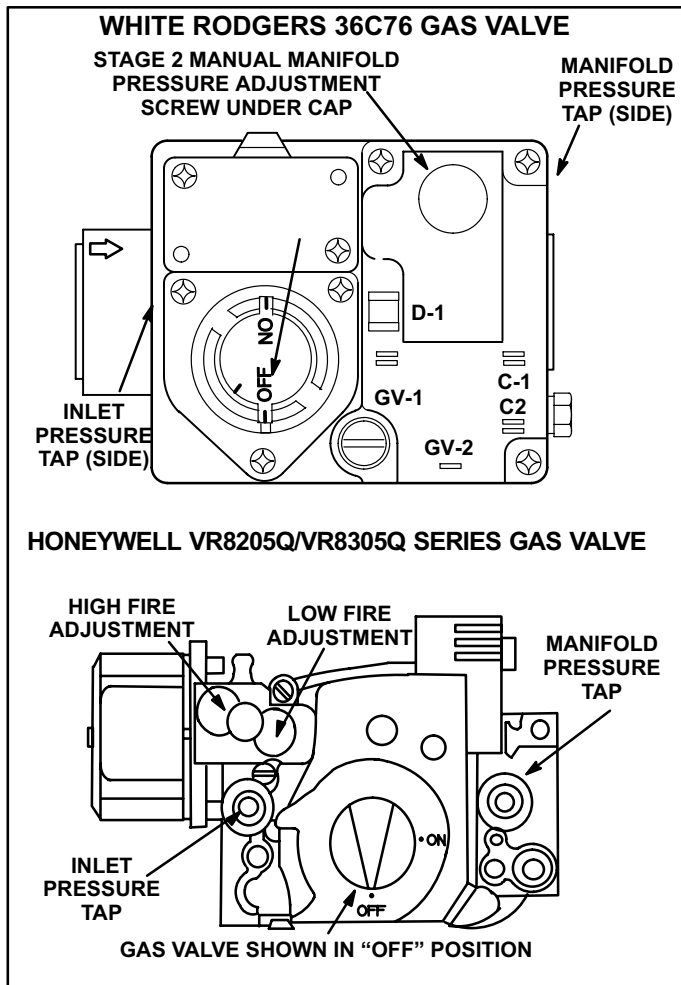

FIGURE 18

10-Ignitor / Flame Sensor Figure 19

Ignitor tips are located in the path of the left most burner. The sensor tip is located in the right most burner path. Both ignitor and sensor are fastened to the lower burner bracket. See figure 13. **The sensor and ignitor are identical components. However, each line up differently to the center line of the burner.** See figure 20. During ignition, spark travels through the ignitor electrode and arcs across to the ground electrode. During operation, flame is sensed by a current passed along the ground electrode, through the flame and into the sensor.

a-Spark Electrode

The spark electrode is connected to the ignition control by a 5mm silicone insulated stranded high voltage wire. The wire uses 1/4" female quick connect on the electrode end and female spark plug-type terminal on the ignition control end. See figure 20 for gap dimensions

b-Flame Sensor

Flame is sensed by rectification through the flame sensing rod.

⚠ IMPORTANT

In order to maximize spark energy to the electrode, the high voltage wire should not rest on the bottom of unit vestibule panel and should touch unit cabinet as little as possible.

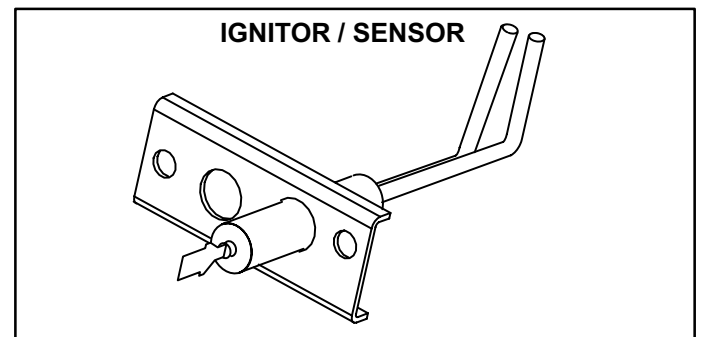

FIGURE 19

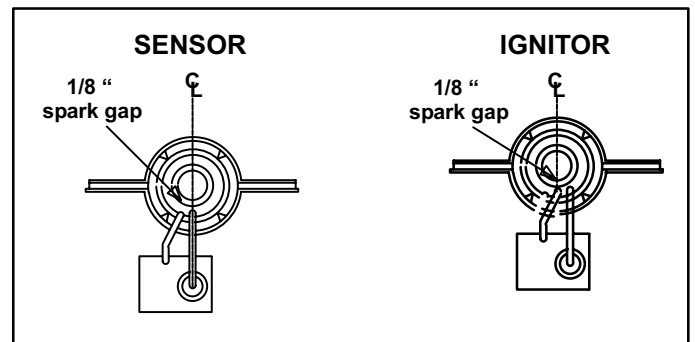
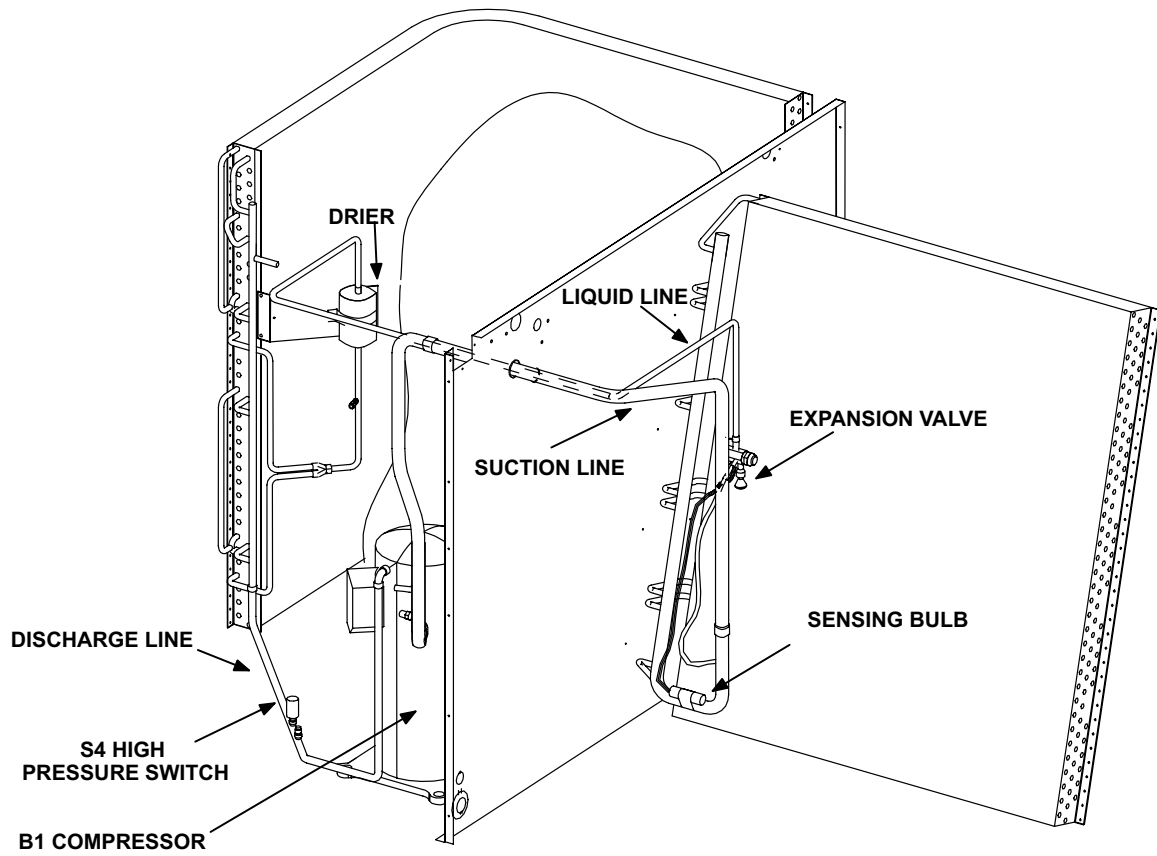

FIGURE 20

PLUMBING COMPONENTS GCS/CHA16-072



PLUMBING COMPONENTS GCS/CHA16-090

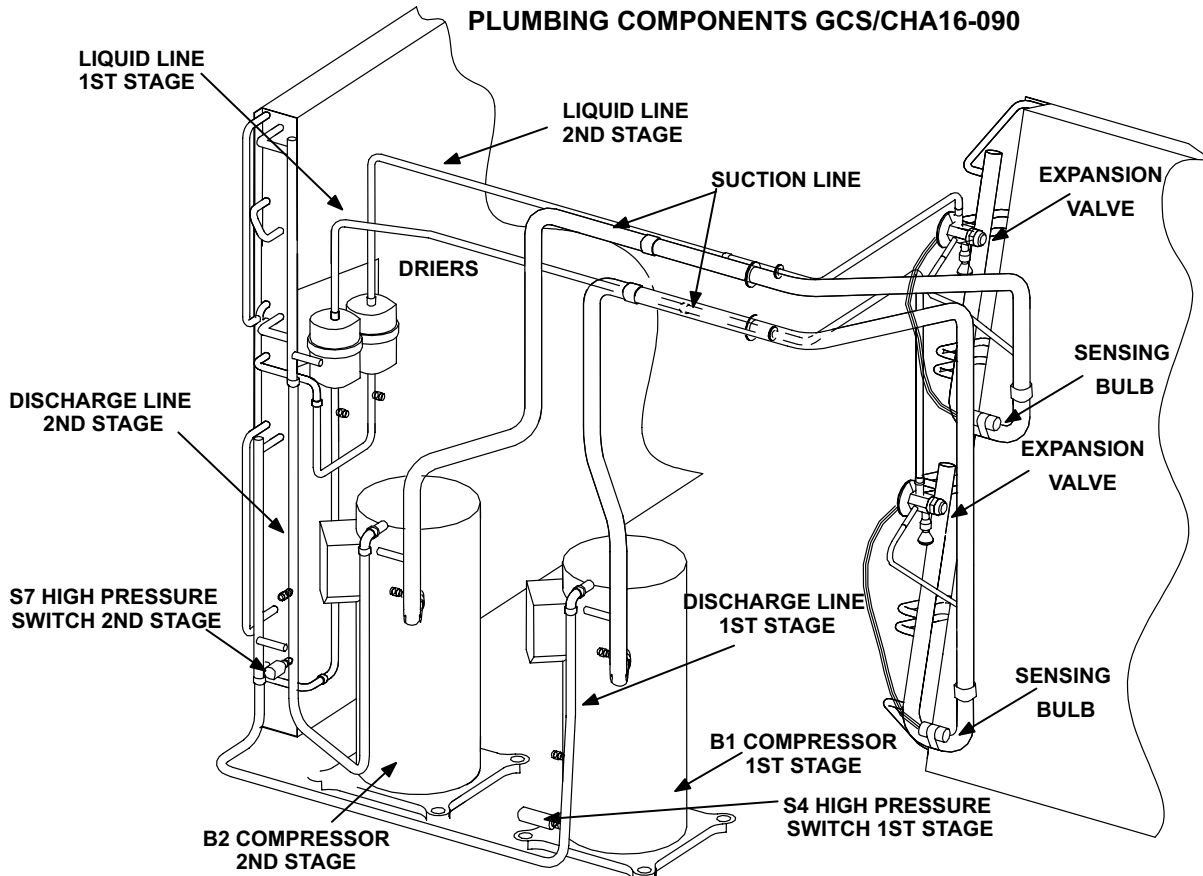

FIGURE 21

PLUMBING COMPONENTS GCS/CHA16-120/150

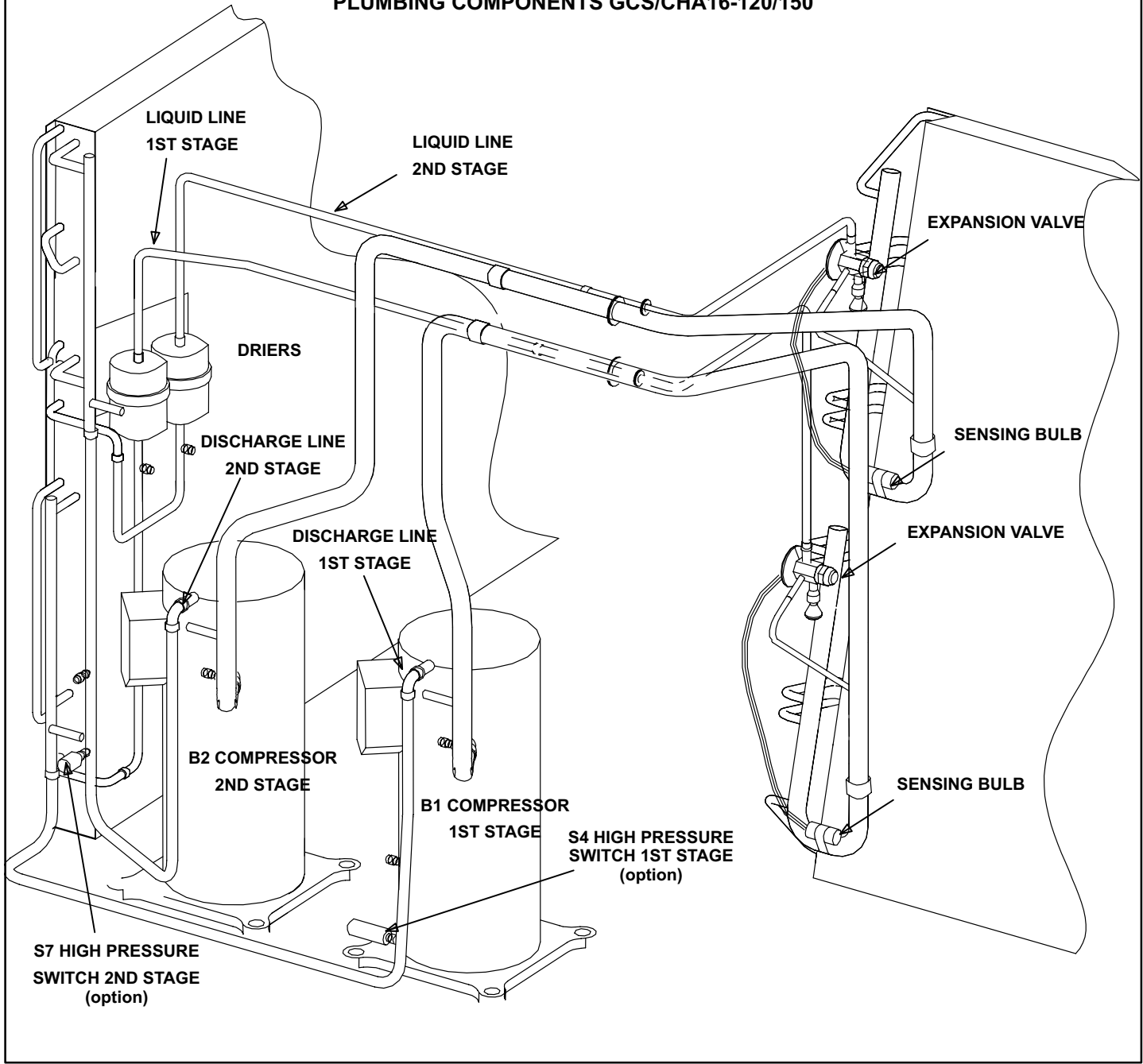

FIGURE 22

D-Cooling Components

Summary of Features

All units use DX cooling. Cooling in GCS/CHA16 units may also be supplemented by field-installed economizer. All units use a single slab-type enhanced fin evaporator with rifled tubing and a thermal expansion valve ("TXV") as the expansion device (figures 21). All models use draw-through type condenser fans.

1-Scroll Compressor

All GCS/CHA16 units utilize a scroll compressor. The GCS/CHA16-072 will have one compressor and the GCS/CHA16-090/120/150 will have two. The scroll compressor design is simple, efficient and requires few moving parts. A cut-away diagram of the scroll compressor is shown in figure 23. The scrolls are located in the top of the compressor can and the motor is located in the bottom of the compressor can.

The oil level is immediately below the motor and oil is pressure fed to the moving parts of the compressor. The lower portion of the compressor shell is exposed to low side pressure while only the very top of the shell is exposed to high side pressure.

The scroll is a simple compression concept centered around the unique spiral shape of the scroll and its inherent properties. Figure 24 shows the basic scroll form. Two identical scrolls are mated together forming concentric spiral shapes (figure 25). One scroll remains stationary, while the other is allowed to orbit (figure 26-1). Note that the orbiting scroll does not rotate or turn but merely orbits the stationary scroll.

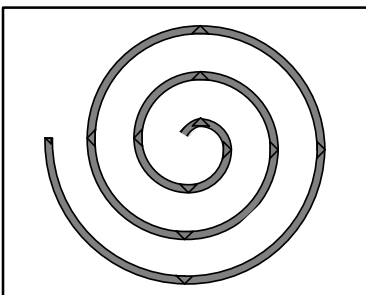

FIGURE 24

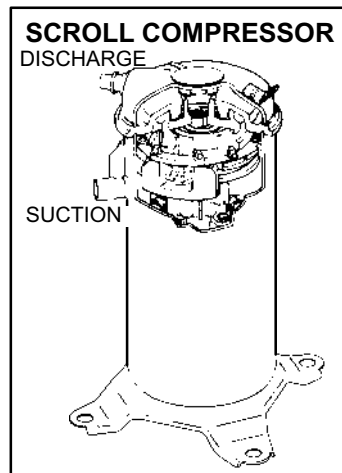

FIGURE 23

The counterclockwise orbiting scroll draws gas into the outer crescent shaped gas pocket created by the two scrolls (figure 26-2). The centrifugal action of the orbiting scroll seals off the flanks of the scrolls (figure 26-3). As the orbiting motion continues, the gas is forced toward the center of the scroll and the gas pocket becomes compressed (figure 26-4).

When compressed gas reaches the center, it is discharged vertically into a chamber and discharge port in the top of the compressor (figure 23). The discharge pressure forcing down on the top scroll helps seal the upper and lower edges (tips) of the scrolls (figure 25). During a single orbit, several pockets of gas are compressed simultaneously providing smooth continuous compression.

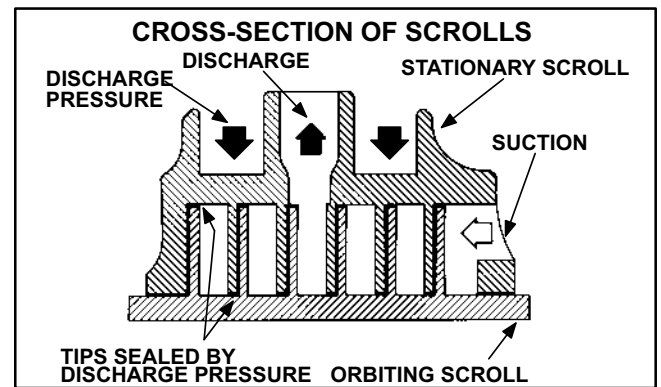



FIGURE 25

⚠ DANGER

Shock hazard.

Compressor must be grounded. Do not operate without protective cover over terminals. Capacitors contain high voltage. Disconnect power before removing cover. Discharge capacitors before servicing unit. Disconnect power before servicing unit.

Can cause unsafe operation, injury or death.



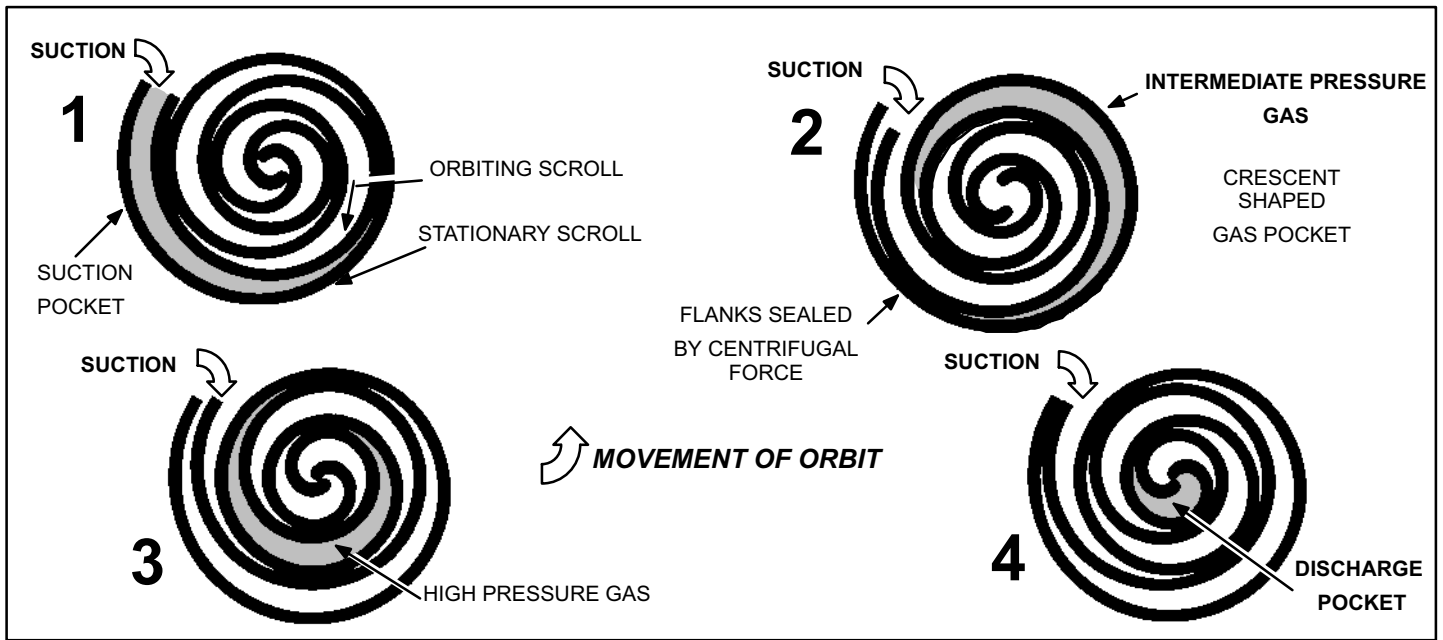

FIGURE 26

The scroll compressor is tolerant to the effects of liquid return. If liquid enters the scrolls, the orbiting scroll is allowed to separate from the stationary scroll. The liquid is worked toward the center of the scroll and is discharged. If the compressor is replaced, conventional Lennox cleanup practices must be used.

Due to its efficiency, the scroll compressor is capable of drawing a much deeper vacuum than reciprocating compressors. Deep vacuum operation can cause internal fusite arcing resulting in damaged internal parts and compressor failure. It is permissible to “pump-down” the system using the compressor but never use a scroll compressor for drawing a vacuum on the system. This type of damage can be detected and will result in denial of warranty claims.

⚠ CAUTION

The head of a scroll compressor may be hot since it is in constant contact with discharge gas. Contact could result in serious burns.

For compressor specifications see compressor nameplate or ELECTRICAL DATA section in this manual. All compressors are protected by internal overload protection circuitry.

2-Condenser Fan and Motor B4 & B5

The specifications section in this manual shows the specifications of condenser fans used in GCS/CHA16s'. The condenser fan is controlled by cooling contactor K1.

3-Indoor Blower Motor B3

All GCS/CHA16 model units use three-phase, PSC, belt driven blower motors. See motor nameplate or ELECTRICAL DATA section for motor specifications.

4-Evaporator Coil

All GCS/CHA16 model units have a single slab evaporator coil. The coil in the GCS/CHA16-072/090/120 has three rows and the GCS/CHA16-150 has four rows, of rifled copper tubes fitted with ripple-edged aluminum fins. A Thermal Expansion Valve (TXV) feeds multiple parallel circuits through the coil. See figure 27.

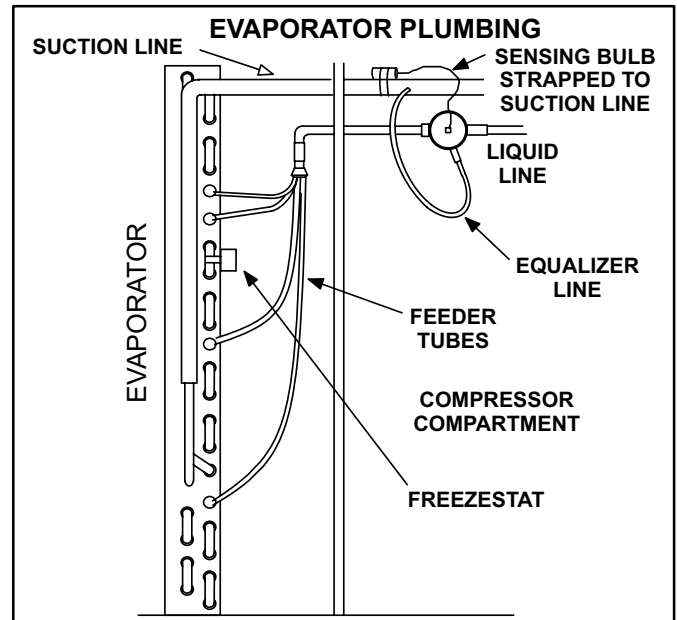

FIGURE 27

5-Condenser Coil

All GCS/CHA16 model units have a single condenser coil. Each coil has two rows of copper tubes fitted with ripple-edged aluminum enhanced fins.

6-High Pressure Switch S4 & S7

High pressure switch S4 (compressor 1) and S7 (compressor 2) are manually reset SPST N.C. high pressure switches which open on pressure rise. S4 is located on the discharge line (compressor 1) and wired in series with compressor contactor K1. S7 is located on the discharge line (compressor 2) and wired in series with compressor contactor K2. When discharge pressure rises above 450 ± 10 psig ($3103 \text{ kPa} \pm 69 \text{ kPa}$) the switch opens and the compressor is de-energized (the economizer can continue to operate). After the problem has been found and corrected, the switch can be reset by pushing-in the switch button. The high pressure switches are standard components on the GCS/CHA16-072/090 but optional on the GCS/CHA16-120/150.

7-Freezestat Switch S49 & S50

All GCS/CHA16 model units are equipped with a low temperature freezestat switch. S49 is wired in series with high pressure switch S4 and compressor contactor K1 for all models. S50 is wired in series with outdoor fan relay K10, optional high pressure switch S7 and compressor contactor K2 on the -090120/150 models only. S49 and S50 are SPST N.C. auto-reset switches which open at $29^\circ\text{F} \pm 3^\circ\text{F}$ ($-1.7^\circ\text{C} \pm 1.7^\circ\text{C}$) on temperature drop and close at $58^\circ\text{F} \pm 4^\circ\text{F}$ ($14.4^\circ\text{C} \pm 2.2^\circ\text{C}$) on a temperature rise. To prevent coil icing, freezestats open during compressor operation to temporarily disable the compressor(s) until the coil warms sufficiently to melt any accumulate frost.

If freezestats trip frequently due to coil icing, check the unit charge, air flow and filters before allowing unit back in operation. Make sure to eliminate conditions which might promote ice build up.

8-Drier

All GCS/CHA16 model units have a filter drier located in the liquid line of each refrigerant circuit at the exit of each condenser coil. The drier removes contaminants and moisture from the system.

III-Optional Electric Heat

Tables 4 through 7 show all possible CHA16 to ECH16 matchups and electrical ratings. ECH16 parts arrangement is shown in figure 28. All ECH16 units consist of electric heat elements exposed directly to the airstream. Multiple-stage elements are sequenced on and off by time delays in response to thermostat demand.

1-Contactor K15

Contactor K15 is a three-pole double-break contactor located in the control box. All ECH16 electric heat sections are equipped with K15. K15 is equipped with a 24VAC coil which is energized when pilot relay K9 closes. When K15 is energized, the heating elements (first stage heating elements if equipped with multi-stage heater) are energized.

2-Contactor K16

Contactor K16 is also a three-pole double-break contactor located in the control box. All multiple stage ECH16 electric heat sections are equipped with K16. K16 is equipped with a 24VAC coil which is energized after time delay DL2 closes. When K16 is energized, the second stage heating elements are energized.

3-Contactor K17

Contactor K17 is also a three-pole double-break contactor located in the control box. All three stage ECH16 electric heat sections are equipped with K17. K17 has a 24VAC coil which is energized after time delays DL2 and DL4 close in sequence. When K17 is energized, the third-stage heating elements are energized.

4-Contactor K18

Contactor K18 is also a three-pole double-break contactor located in the control box. ECH16-135-50 208/230V electric heat units are equipped with K18. K18 has a 24VAC coil which is energized after time delays DL2, DL4 and DL5 close in sequence. When K18 is energized, fourth-stage heating elements are energized.

5-Relay K9

Relay K9 is a three-pole double-throw pilot relay intended to electrically isolate the CHA16 and ECH16 24V circuits. The coil of relay K9 is connected to first stage heating demand from the CHA16. When K9 is energized, three sets of contacts switch. When K9-1 switches, the indoor blower is energized. When K9-2 closes, second stage electric heat is enabled (but not energized until second stage demand is received from the thermostat). When K9-3 closes, contactor K15 is energized.

TABLE 4

CHA16-072 MODELS					
Electric Heat Model No. & Net Weight	No. of Steps	Volts Input	kw Input	Btuh Output	†Total Unit & Electric Heat Minimum Circuit Ampacity
ECH16-82/95-10 208/230v (61H68) 460v (61H73) 575v (61H78) 38 lbs. (17 kg)	1	208	7.5	25,600	40
		220	8.4	28,700	
		230	9.2	31,400	
		240	10.0	34,100	
	1	440	8.4	28,700	20
		460	9.2	31,400	
		480	10.0	34,100	
	1	550	8.4	28,700	16
		575	9.2	31,400	
600		10.0	34,100		
ECH16-82/95-15 208/230v (61H69) 460v (61H74) 575v (61H79) 38 lbs. (17 kg)	1	208	11.3	38,600	49
		220	12.6	43,000	
		230	13.5	46,100	
		240	15.0	51,200	
	1	440	12.6	43,000	27
		460	13.8	46,100	
		480	15.0	51,200	
	1	550	12.6	43,000	22
		575	13.8	46,100	
		600	15.0	51,200	
ECH16-82/95-20 208/230v (61H70) 460v (61H75) 575v (61H80) 42 lbs. (19 kg)	□2	208	15.0	51,200	62
		220	16.8	57,300	
		230	18.4	62,800	
		240	20.0	68,300	
	1	440	16.8	57,300	35
		460	18.4	62,800	
	1	480	20.0	68,300	28
		550	16.8	57,300	
1	575	18.4	62,800	28	
	600	20.0	68,300		
ECH16-82/95-30 208/230v (61H71) 460v (61H76) 575v (61H81) 42 lbs. (19 kg)	□2	208	22.5	76,800	88
		220	25.2	86,000	
		230	27.5	93,900	
		240	30.0	102,400	
	1	440	25.2	86,000	50
		460	27.6	93,900	
		480	30.0	102,400	
	1	550	25.2	86,000	40
		575	27.6	93,900	
		600	30.0	102,400	
ECH16-82/95-40 208/230v (61H72) 460v (61H77) 575v (61H82) 53 lbs. (24 kg)	□3	208	30.0	102,400	114
		220	33.6	114,700	
		230	36.8	125,600	
		240	40.0	136,500	
	□2	440	33.6	114,700	65
		460	36.8	125,600	
	□2	480	40.0	136,500	52
		550	33.6	114,700	
	□2	575	36.8	125,600	52
600		40.0	136,500		

†Refer to National or Canadian Electrical Code manual to determine wire, fuse and disconnect size requirements. Use wires suitable for at least 167°F (75°C).
 □ May be used with two stage control.

TABLE 5

CHA16-090 MODELS					
Electric Heat Model No. & Net Weight	No. of Steps	Volts Input	kw Input	Btuh Output	†Total Unit & Electric Heat Minimum Circuit Ampacity
ECH16-82/95-10 208/230v (61H68) 460v (61H73) 575v (61H78) 38 lbs. (17 kg)	1	208	7.5	25,600	42
		220	8.4	28,700	
		230	9.2	31,400	
		240	10.0	34,100	
	1	440	8.4	28,700	21
		460	9.2	31,400	
		480	10.0	34,100	
	1	550	8.4	28,700	17
		575	9.2	31,400	
600		10.0	34,100		
ECH16-82/95-15 208/230v (61H69) 460v (61H74) 575v (61H79) 38 lbs. (17 kg)	1	208	11.3	38,600	49
		220	12.6	43,000	
		230	13.5	46,100	
		240	15.0	51,200	
	1	440	12.6	43,000	27
		460	13.8	46,100	
		480	15.0	51,200	
	1	550	12.6	43,000	22
		575	13.8	46,100	
		600	15.0	51,200	
ECH16-82/95-20 208/230v (61H70) 460v (61H75) 575v (61H80) 42 lbs. (19 kg)	□2	208	15.0	51,200	62
		220	16.8	57,300	
		230	18.4	62,800	
		240	20.0	68,300	
	1	440	16.8	57,300	35
		460	18.4	62,800	
	1	480	20.0	68,300	28
		550	16.8	57,300	
1	575	18.4	62,800	28	
	600	20.0	68,300		
ECH16-82/95-30 208/230v (61H71) 460v (61H76) 575v (61H81) 42 lbs. (19 kg)	□2	208	22.5	76,800	88
		220	25.2	86,000	
		230	27.5	93,900	
		240	30.0	102,400	
	1	440	25.2	86,000	50
		460	27.6	93,900	
		480	30.0	102,400	
	1	550	25.2	86,000	40
		575	27.6	93,900	
		600	30.0	102,400	
ECH16-82/95-40 208/230v (61H72) 460v (61H77) 575v (61H82) 53 lbs. (24 kg)	□3	208	30.0	102,400	114
		220	33.6	114,700	
		230	36.8	125,600	
		240	40.0	136,500	
	□2	440	33.6	114,700	65
		460	36.8	125,600	
	□2	480	40.0	136,500	52
		550	33.6	114,700	
	□2	575	36.8	125,600	52
600		40.0	136,500		

†Refer to National or Canadian Electrical Code manual to determine wire, fuse and disconnect size requirements. Use wires suitable for at least 167°F (75°C).
 □ May be used with two stage control.

TABLE 6

CHA16-120 MODELS							
Electric Heat Model No. & Net Weight	No. of Steps	Volts Input	kw Input	Btuh Output	†Total Unit & Electric Heat Minimum Circuit Ampacity		
ECH16-135-15 208/230v (72G21) 460v (72G26) 575v (72G31) 38 lbs. (17 kg)	1	208	11.3	38,600	59		
		220	12.6	43,000			
		230	13.5	46,100			
		240	15.0	51,200			
	1	440	12.6	43,000	29		
		460	13.8	46,100			
		480	15.0	51,200			
	1	550	12.6	43,000	23		
		575	13.8	46,100			
600		15.0	51,200				
ECH16-135-20 208/230v (72G22) 460v (72G27) 575v (72G32) 42 lbs. (19 kg)	1	208	15.0	51,200	74		
		220	16.8	57,300			
		230	18.4	62,800			
		240	20.0	68,300			
	1	440	16.8	57,300	37		
		460	18.4	62,800			
		480	20.0	68,300			
		550	16.8	57,300			
	1	575	18.4	62,800	29		
		600	20.0	68,300			
		†12	208	22.5		76,800	104
			220	25.2		86,000	
230	27.5		93,900				
240	30.0		102,400				
†12	440	25.4	86,000	52			
	460	27.5	93,900				
	480	30.0	102,400				
	550	25.2	86,000				
†12	575	27.6	93,900	41			
	600	30.0	102,400				
	†12	208	30.0		102,400	134	
		220	33.6		114,700		
230		36.8	125,600				
240		40.0	136,500				
†12	440	33.6	114,700	67			
	460	36.8	125,600				
	480	40.0	136,500				
	550	33.6	114,700				
†12	575	36.8	125,600	53			
	600	40.0	136,500				
	†12	208	37.5		128,000	134	
		220	42.0		143,300		
230		46.0	157,000				
240		50.0	170,600				
†12	440	43.8	149,500	67			
	460	46.0	157,000				
	480	50.0	170,600				
	550	43.8	149,500				
†12	575	46.0	157,000	53			
	600	50.0	170,600				

†Refer to National or Canadian Electrical Code manual to determine wire, fuse and disconnect size requirements. Use wires suitable for at least 167°F (75°C).
 †May be used with two stage control.

TABLE 7

CHA16-150 MODELS							
Electric Heat Model No. & Net Weight	No. of Steps	Volts Input	kw Input	Btuh Output	†Total Unit & Electric Heat Minimum Circuit Ampacity		
ECH16-135-15 208/230v (72G21) 460v (72G26) 575v (72G31) 38 lbs. (17 kg)	1	208	11.3	38,600	59		
		220	12.6	43,000			
		230	13.5	46,100			
		240	15.0	51,200			
	1	440	12.6	43,000	29		
		460	13.8	46,100			
		480	15.0	51,200			
	1	550	12.6	43,000	24		
		575	13.8	46,100			
600		15.0	51,200				
ECH16-135-20 208/230v (72G22) 460v (72G27) 575v (72G32) 42 lbs. (19 kg)	1	208	15.0	51,200	74		
		220	16.8	57,300			
		230	18.4	62,800			
		240	20.0	68,300			
	1	440	16.8	57,300	37		
		460	18.4	62,800			
		480	20.0	68,300			
		550	16.8	57,300			
	1	575	18.4	62,800	29		
		600	20.0	68,300			
		†12	208	22.5		76,800	104
			220	25.2		86,000	
230	27.5		93,900				
240	30.0		102,400				
†12	440	25.4	86,000	52			
	460	27.5	93,900				
	480	30.0	102,400				
	550	25.2	86,000				
†12	575	27.6	93,900	41			
	600	30.0	102,400				
	†12	208	30.0		102,400	134	
		220	33.6		114,700		
230		36.8	125,600				
240		40.0	136,500				
†12	440	33.6	114,700	67			
	460	36.8	125,600				
	480	40.0	136,500				
	550	33.6	114,700				
†12	575	36.8	125,600	53			
	600	40.0	136,500				
	†12	208	37.5		128,000	134	
		220	42.0		143,300		
230		46.0	157,000				
240		50.0	170,600				
†12	440	43.8	149,500	67			
	460	46.0	157,000				
	480	50.0	170,600				
	550	43.8	149,500				
†12	575	46.0	157,000	53			
	600	50.0	170,600				

†Refer to National or Canadian Electrical Code manual to determine wire, fuse and disconnect size requirements. Use wires suitable for at least 167°F (75°C).
 †May be used with two stage control.

6-Relay K19

Relay K19 is a single-pole double-throw pilot relay also intended to electrically isolate the CHA16 24VAC circuits from the ECH16 24V circuits. The coil of relay K19 is connected to second-stage heating demand from the CHA16. When K19 is energized, a single set of contacts switch. When K19-1 closes, second-stage electric heat is energized.

7-Time Delay DL2

Time delay DL2 is factory installed in all multiple-stage electric heat units. DL2 allows staging by providing a timed interval between the first and second heating elements. The delay control is a single-pole single-throw 24VAC relay with normally open contacts. When the relay coil is energized, the contacts are delayed 30 seconds before closing. When the relay coil is de-energized, the contacts are delayed 1 second before opening.

DL2 is energized with first stage thermostat demand in 50kW 208/230V electric heat units. In all other multiple-stage electric heat units, DL2 is energized only after receiving a second stage thermostat demand.

8-Time Delay DL4

Time delay DL4 is identical to DL2. It is factory installed in all multiple-stage electric heat units with at least three stages of electric heat. DL4 allows staging by providing a timed interval between the second and third heating elements. The delay is identical to DL2.

DL4 is energized with second stage thermostat demand in 50kW 208/230V electric heat units. In all other multiple-stage electric heat units, DL4 is energized only after time delay DL2 closes.

9-Time Delay DL5

Time delay DL5 is only used in 50kW 208/230V electric heat units. The delay is identical to DL2 and DL4. DL5 allows four stages of heat by providing a timed interval between the third and fourth heating elements.

10-Fuse F3

F3 is a current limiting fuse connected in series with each leg of electric heat (each stage of electric heat uses three fuses). Fuses used in CHA16 series heating sections are shown in table 8.

TABLE 8

CHA16 ELECTRIC HEAT SECTION FUSE RATINGS				
kW Voltage	F3 1st Stage	F3 2nd sTAGE	F3 3rd Stage	F3 4th Stage
10kW 208/230V	60 Amp 250V			
10kW 460, 575V	30 amp 600V			
15kW 208/230V	60 Amp 250V			
15kW 460, 575V	30 Amp 600V			
20kW 208/230V	60 Amp 250V	60 Amp 250V	60 Amp 250V	
20kW 460, 575V	60 Amp 600V			
30kW 208/230V	60 Amp 250V	60 Amp 250V	60 Amp 250V	
30kW 460, 575V	60 Amp 600V			
40kW 208/230V	60 Amp 250V	60 Amp 250V		
40kW 460, 575V	60 Amp 600V	30 Amp 600V	60 Amp 600V	
50kW 208/230V	60 Amp 250V	30 Amp 600v	60 Amp 600V	30 Amp 600V
50kW 460, 575V	60 Amp 600V	30 Amp 600V		

11-High Temperature Limit S15 (Primary)

S15 is the primary high temperature limit. It is located in the electric heat unit immediately downstream from the heating elements. S15 is a single-pole single-throw normally closed thermostat wired in series with the first stage contactor coil.

When S15 opens, indicating a problem in the system, contactor K15 is de-energized. When K15 is de-energized, first stage and all subsequent stages of heat are de-energized. Since the indoor blower is controlled by demand (K9 remains energized), the indoor blower continues operating.

12-High Temperature Limit S20 (Secondary)

Each heating element assembly is electrically connected to two high temperature limits S20 (refer to wiring diagrams in back of this manual). Each limit is connected in series with one leg of the three-phase element assembly. The third leg of each assembly is not equipped with a limit. Three-phase operating characteristics allow one of the other two limits to protect the third leg.

Each S20 limit is physically located adjacent to the element it is protecting. S20 is a single-pole normally closed thermostat. The thermostat actuates on a temperature rise and cannot be reset. Once tripped, it must be replaced.

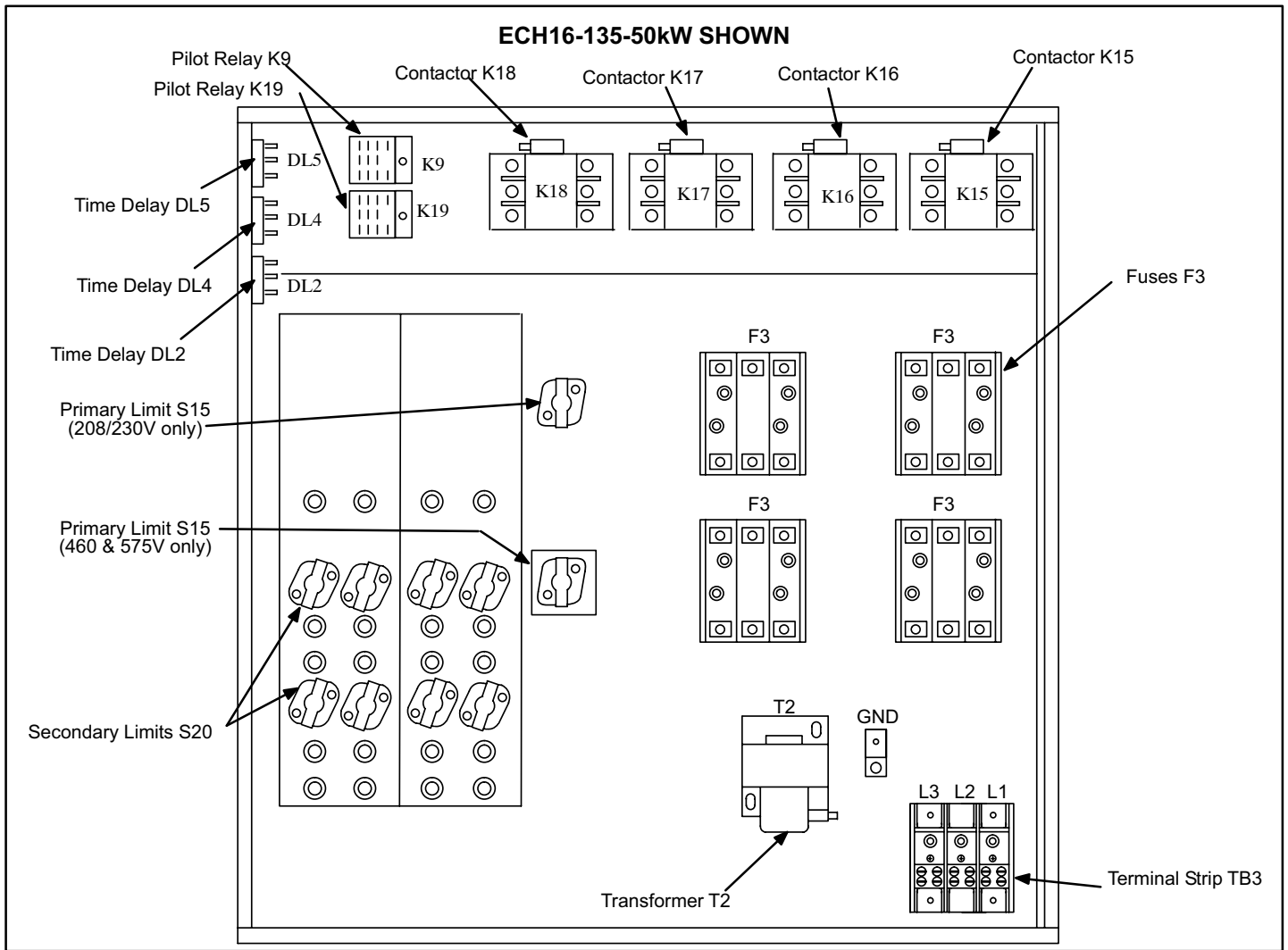

FIGURE 28

13-Terminal Strip TB3

Electric heat line voltage connections are made to terminal strip TB3 located in the electric heat make up box. CHA16 unit electrical connections are also made here.

14-Transformer T2

T2 is a line voltage to 24V transformer located in the electric heat control box. The transformer provides 24VAC power to all ECH16 controls (contactor coils and time delays). Pilot relays (K9 and K19) plug-in to the CHA16 provide 24V circuit isolation.

15-Heating Elements

Heating elements are composed of helix wound bare nichrome exposed directly to the airstream. Heating elements are energized directly by contactors in the ECH16 control box. Once energized, heat transfer is instantaneous. Overtemperature protection is provided by primary and secondary high temperature limits. Overcurrent protection is provided by fuses. Each stage of electric heat consists of three elements connected in a three-phase arrangement. Elements in 208/230V units are connected in a "Delta" arrangement. Elements in 460 and 575V units are connected in "Wye" arrangement.

Each stage is energized independently by a three-pole double-break contactor and is protected by safety limits.

IV-PLACEMENT AND INSTALLATION

Make sure the unit is installed in accordance with the installation instructions and all applicable codes. See accessories section for conditions requiring use of the optional roof mounting frame (RMF16).

V-ELECTRICAL CONNECTIONS

A-Field Wiring

Unit field wiring is shown in the unit diagram section of this manual.

B-Power Supply

Refer to start-up directions and refer closely to the unit wiring diagram when servicing. Refer to unit nameplate for minimum circuit ampacity and maximum fuse size. **208 volt units are field wired with red wire connected to control transformer primary. 230 volt units are factory wired with orange wire connected to control transformer primary.**



VI-INDOOR BLOWER OPERATION / ADJUSTMENT

A-Blower Operation

- 1- Blower operation is manually set at the thermostat sub-base fan switch. With fan switch in **ON** position, blowers will operate continuously.
- 2- With fan switch in **AUTO** position, the blowers will cycle with demand. Blowers and entire unit will be off when system switch is in **OFF** position.

B-Determining Unit CFM

- 1- The following measurements must be made with a dry indoor coil. Run blower without a cooling demand. Air filters must be in place when measurements are taken.
- 2- With all access panels in place, measure static pressure external to unit (from supply to return).
- 3- Measure the indoor blower motor RPM.
- 4- Refer to table in "BLOWER DATA" section. Use static pressure and RPM readings to determine unit CFM.
- 5- The CFM can be adjusted at the motor pulley. Loosen Allen screw and turn adjustable pulley clockwise to increase CFM. Turn counterclockwise to decrease CFM. See figure 29.

C-Blower Belt Adjustment

NOTE - Remove shipping screw from top of motor mounting plate on units shipped with belt loose.

Maximum life and wear can be obtained from belts only if proper pulley alignment and belt tension are maintained. Tension new belt after a 24-48 hour period of operation. This will allow belt to stretch and seat grooves. To increase belt tension, loosen locking bolt and pull mounting plate. Tighten bolt so that the motor mounting plate is in a vertical position. See figure 29.

D-Check Belt Tension

Overtensioning belts shortens belt and bearing life. Check belt tension as follows:

- 1- Measure span length X. See figure 30.
- 2- Apply perpendicular force to center of span (X) with enough pressure to deflect belt 1/64" for every inch of span length or 1.5mm per 100mm of span length.

Example: Deflection distance of a 40" span would be 40/64" or 5/8".

Example: Deflection distance of a 400mm span would be 6mm.

- 3- Measure belt deflection force. For a used belt, the deflection force should be 5 lbs. (35kPa). A new belt deflection force should be 7 lbs. (48kPa).

A force below these values indicates an undertensioned belt. A force above these values indicates an overtensioned belt.

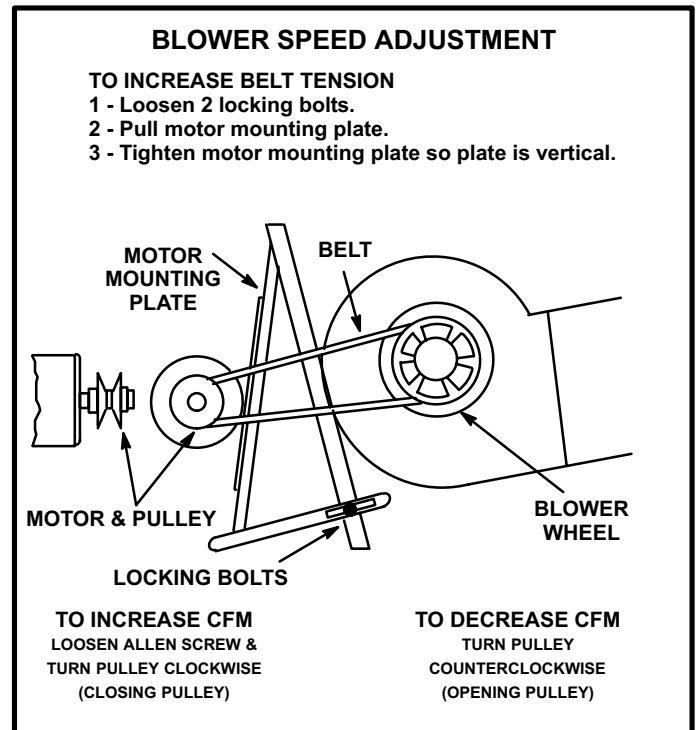

FIGURE 29

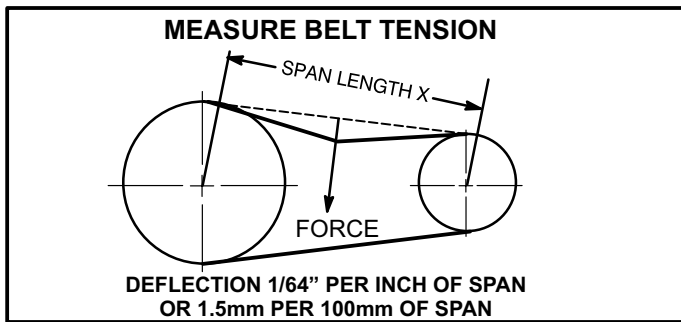

FIGURE 30

E- To Measure Discharge Static Pressure

1 - Locate tap locations as shown in figure 31.

2 - Punch a 1/4" diameter hole. Insert manometer hose flush with the inside edge of hole or insulation. Seal around hole with perma-gum. Connect zero end of manometer to the discharge (supply) side of system. Connect other end of manometer to return duct as above.

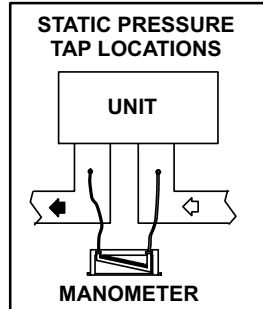

FIGURE 31

3 - With only the blower motor running, observe the manometer reading.

4 - See figure 29 for speed change instructions.

5 - Seal the hole when check is complete.

VII-START-UP OPERATION

A-Preliminary Checks

- 1 - Make sure unit is installed in accordance with the installation instructions and applicable codes.
- 2 - Inspect electrical wiring, both field and factory installed for loose connections. Tighten as required.
- 3 - Check to ensure that refrigerant lines are in good condition and do not rub against the cabinet or other refrigerant lines.
- 4 - Check voltage at the disconnect switch. Voltage must be within range listed on the nameplate. If not, consult the power company and have the voltage condition corrected before starting the unit.
- 5 - Recheck voltage with unit running. If power is not within range listed on unit nameplate, stop unit and consult power company. Check amperage of unit. Refer to nameplate for rated running amps.

B-Cooling Start Up

- 1 - Set fan switch to **AUTO** or **ON** and move system selection switch to cool. Adjust thermostat to a setting below room temperature to bring on all compressors. Compressors will start and cycle on demand from thermostat.
- 2 - Each refrigerant circuit is separately charged with R-22 refrigerant. See unit rating plate for correct amount of charge.

- 3 - Refer to REFRIGERATION SYSTEM SERVICE CHECK section for proper method to check refrigerant charge.

C-Three Phase Scroll Compressor

Three phase scroll compressors must be phased sequentially to ensure correct compressor rotation and operation.

At compressor start-up, a rise in discharge and drop in suction pressures indicates proper compressor phasing and operation. Excessive compressor noise may also indicate incorrect phasing. If discharge and suction pressures do not function normally, follow these steps:

- 1 - Disconnect field power supply to unit.
- 2 - Reverse any two field power leads to the unit.
- 3 - Reapply field power supply to unit.

Discharge and suction pressures should operate at their normal start-up ranges.

D-Heating Start Up (GCS16 Models)

⚠ WARNING

Shock and burn hazard.

This unit is equipped with a direct spark ignition system. Do not attempt to light manually.

BEFORE LIGHTING smell all around the appliance area for gas. Be sure to smell next to the base of unit because some gas is heavier than air and will settle on the floor or base.

Use only your hand to push in or turn the gas control knob. Never use tools. If the knob will not push in or turn by hand, do not try to repair it, call a qualified service technician. Force or attempted repair may result in a fire or explosion.

Gas Valve Operation (Figure 32)

1-Placing Furnace In Operation

This unit is equipped with an automatic spark ignition system. There is no pilot. In case of a safety shutdown, move thermostat switch to "OFF," then return the thermostat switch to "HEAT" position.

- 1 - Set thermostat to lowest setting.
- 2 - Turn off all electrical power to appliance.
- 3 - This appliance is equipped with an ignition device which automatically lights the burner. Do **not** try to light by hand.
- 4 - Remove heat access panel
- 5 - Honeywell valve - Turn knob on gas valve clockwise to off. Do not force. White-Rodgers valve - Depress slightly. Do not force.
- 6 - Wait 5 minutes to clear out any gas. If you then smell gas, STOP! Immediately call the gas supplier from a neighboring building. Follow the gas suppliers instructions. If you do not smell gas go to the next step.

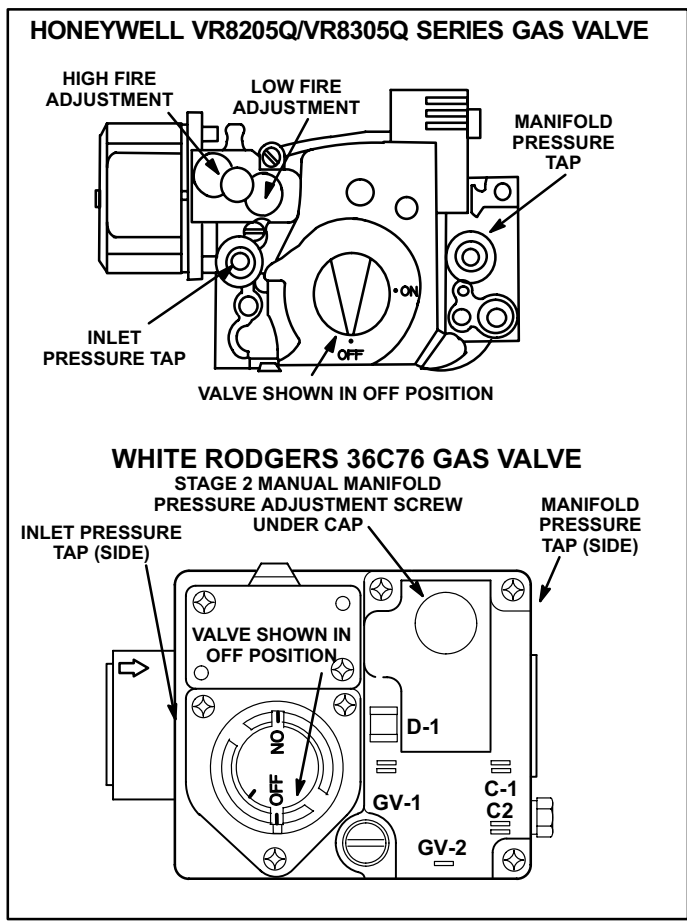

FIGURE 32

- 7- Turn knob on gas valve counterclockwise to ON.
- 8- Replace heat access panel.
- 9- Turn on all electrical power to unit.
- 10- Set thermostat to desired setting.
- 11- If the appliance will not operate, follow the instructions "To Turn Off Gas To Unit".

2- To Turn Off Gas To Unit

- 1 - Set thermostats to lowest setting.
- 2 - Turn off electrical power to unit if service is to be made.
- 3 - Remove heat section access panel.
- 4 - Honeywell valve - Turn knob on gas valve clockwise to OFF. White Rodgers valve - Depress slightly. Do not force.
- 5 - Replace heat section access panel.

E-Safety or Emergency Shutdown:

Turn off power to the unit. Close the manual and/or main gas valves.

F-Extended Period Shutdown:

Turn off the thermostat or set to "UNOCCUPIED" mode. Close all gas valves both internal and external to the unit to prevent gas leakage into the combustion chamber. Turn off power to the unit. All access panels, covers and vent caps must be in place and secured.

VIII-REFRIGERATION SYSTEM SERVICE CHECKS

WARNING-Do not exceed nameplate charge under any conditions.

This unit is factory charged and should require no further adjustment. If the system requires charge, reclaim the charge, evacuate the system, and add required nameplate charge.

NOTE - System charging is not recommended below 60°F (15°C). In temperatures below 60°F (15°C), the charge **must** be weighed into the system.

If weighing facilities are not available, or to check the charge, use the following procedure:

- 1- Attach gauge manifolds and operate unit in cooling mode until system stabilizes (approximately five minutes). Make sure all outdoor air dampers are closed.
- 2- Check each system separately with all stages operating.
- 3- Use a thermometer to accurately measure the outdoor ambient temperature.
- 4- Apply the outdoor temperature to tables 9, 10, 11 or 12 to determine normal operating pressures.

**TABLE 9
GCS/CHA16-072 NORMAL OPERATING PRESSURES**

Outdoor Coil Entering Air Temp	Discharge ±10 psig	Suction ±5 psig
65°F	190	69
75°F	218	73
85°F	248	75
95°F	280	76
105°F	317	78
115°F	354	80

**TABLE 10
GCS/CHA16-090 NORMAL OPERATING PRESSURES**

Outdoor Coil Entering Air Temp	CIRCUIT 1		CIRCUIT 2	
	Discharge ±10 psig	Suction ±5 psig	Discharge ±10 psig	Suction ±5 psig
65°F	198	74	198	73
75°F	228	76	228	75
85°F	260	78	260	77
95°F	292	79	292	78
105°F	325	80	325	79
115°F	360	82	360	81

**TABLE 11
GCS16/CHA-120 NORMAL OPERATING PRESSURES**

Outdoor Coil Entering Air Temp	CIRCUIT 1		CIRCUIT 2	
	Discharge ±10 psig	Suction ±5 psig	Discharge ±10 psig	Suction ±5 psig
65°F	189	72	184	70
75°F	216	73	210	72
85°F	246	74	240	73
95°F	279	76	272	73
105°F	316	77	310	75
115°F	359	79	354	77

TABLE 12
GCS/CHA16-150 NORMAL OPERATING PRESSURES

Outdoor Coil Entering Air Temp	CIRCUIT 1		CIRCUIT 2	
	Discharge ±10 psig	Suction ±5 psig	Discharge ±10 psig	Suction ±5 psig
65°F	192	66	196	68
75°F	221	70	225	72
85°F	250	71	255	76
95°F	281	73	288	78
105°F	317	74	324	79
115°F	255	75	363	81

- 5- Compare the normal operating pressures to the pressures obtained from the gauges. Minor variations in these pressures may be expected due to differences in installations. Significant differences could mean that the system is not properly charged or that a problem exists with some component in the system. **Correct any system problems before proceeding.**
- 6- If discharge pressure is high, remove refrigerant from the system. If discharge pressure is low, add refrigerant to the system.
 - Add or remove charge in increments.
 - Allow the system to stabilize each time refrigerant is added or removed.
- 7- Use the following approach method along with the normal operating pressures to confirm readings.

Charge Verification - Approach Method
- 8- Using the same thermometer, compare liquid temperature to outdoor ambient temperature.

Approach Temperature = Liquid temperature minus ambient temperature.
- 9- Approach temperature should be as shown in table 13. An approach temperature greater than value shown indicates an undercharge. An approach temperature less than value shown indicates an overcharge.
- 10- Do not use the approach method if system pressures do not match pressures shown. The approach method is not valid for grossly over or undercharged systems.

TABLE 13

GCS/CHA16 UNIT	LIQUID TEMP. MINUS AMBIENT TEMP.	
	STAGE 1	STAGE 2
-072	6°F ± 1 (3.3°C ± 0.5)	N/A
-090	12°F ± 1 (6.7°C ± 0.5)	11°F ± 1 (6.1°C ± 0.5)
-120	10°F ± 1 (5.5°C ± 0.5)	7°F ± 1 (3.8°C ± 0.5)
-150	8°F ± 1 (4.4°C ± 0.5)	9°F ± 1 (5°C ± 0.5)

IX-HEATING SYSTEM SERVICE CHECKS

A-A.G.A./C.G.A.

Applications and Requirements

All GCS16s are A.G.A and C.G.A. design certified without modification.

Refer to the GCS16 Operation and Installation Instruction Manual for more information.

B-Gas Piping

Gas supply piping must not allow more than 0.5"W.C. drop in pressure between gas meter and unit. Supply gas pipe must not be smaller than unit gas connection.

Compounds used on threaded joints of gas piping **MUST** be resistant to the action of L.P. gas.

C-Testing Gas Piping Pressure

⚠ IMPORTANT

In case emergency shutdown is required, turn off the main shut-off valve and disconnect the main power to unit. These controls should be properly labeled by the installer.

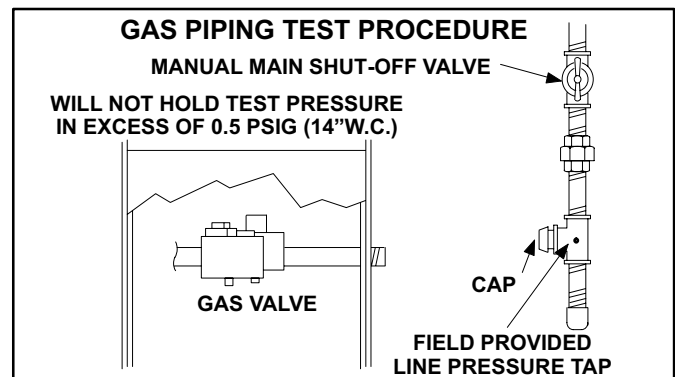

FIGURE 33

When pressure testing gas lines, the gas valve must be disconnected and isolated. Gas valves can be damaged if subjected to more than 0.5 psig (14"W.C.). See Figure 33.

If test pressure is equal to or less than 0.5 psig (14"W.C.), use the main manual shut-off valve before testing to isolate unit from gas supply system.

When checking piping connection for gas leaks, use a soap solution or other preferred means. Common kitchen detergents can cause harmful corrosion on various metals used in gas piping. The use of specialty Gas Leak Detector is strongly recommended. It is available through Lennox under part number 31B2001. **Do not use matches, candles, flame, or other source of ignition to check for gas leaks.**

D-Testing Gas Supply Pressure

When testing gas supply pressure, connect test gauge to the inlet pressure tap (**field provided**). Test supply gas pressure with unit firing at maximum rate. Make sure the reading falls within the range of the following values. Low pressure may result in erratic operation or “underfire.” High pressure may result in permanent damage to the gas valve or “overfire.” For natural gas units, operating pressure at the unit gas connection must be between 4.5”W.C. and 10.5”W.C. For L.P. gas units, operating pressure at the unit gas connection must be between 11.0”W.C. and 13.5”W.C.

On multiple unit installations, each unit should be checked separately, with and without the other units operating. Supply pressure must fall within the range listed in the previous paragraph.

E-Check and Adjust Manifold Pressure

After line pressure has been checked and adjusted, check manifold pressure. Refer back to figure 32 for location of manifold pressure adjustment screw and pressure tap outlet.

The gas valve is factory set and should not require adjustment. All gas valves are factory regulated. Manifold pressure for natural gas is 1.6” low fire *and 3.7” high fire. For L.P. units, manifold pressure is 5.5” low fire* and 10.5” high fire. These manifold pressures are the same for all GCS16 models regardless of input and size. The gas valve should completely and immediately cycle off in the event of gas or power failure. The manual shut-off knob can be used to immediately shut off gas supply.

***NOTE-Do NOT attempt to adjust low fire manifold pressure on White Rodgers valve. Low fire manifold pressure is not adjustable on White Rodgers valve.**

⚠ IMPORTANT

For safety, connect a shut-off valve between the manometer and the gas tap to permit shut off of gas pressure to the manometer.

- 1 - Connect a test gauge to the outlet pressure tap on the gas valve. Start the unit and allow five minutes for the unit to reach steady state.
- 2 - While waiting for the unit to stabilize, notice the flame. The flame should be stable without flashback and should not lift from the burner head. Natural gas should burn blue. L.P. gas should burn mostly blue with some orange streaks.
- 3 - After allowing the unit to stabilize for five minutes, record the manifold pressure. Make adjustments if necessary.
- 4 - Disconnect heating demand as soon as an accurate reading has been obtained.

F-Proper Gas Flow (Approximate)

To check for proper gas flow to burners, determine BTUH input from unit rating plate or the gas heating capacity table in “SPECIFICATIONS” section in this manual. Divide this input rating by the BTUH per cubic foot of available gas. Result is the number of cubic feet per hour required. Determine the flow of gas through gas meter for two minutes and multiply by 30 to get hourly flow of gas to the burners.

G-Flame Sensing

Flame current is an electrical current which passes from the ignition control through the sensor electrode during unit operation. The current passes from the sensor through the flame to ground electrode to complete a safety circuit. The electrodes should be located so the tips are at least 1/2” inside the flame envelope. Do not bend electrodes. To measure flame current, follow the procedure below:

- 1 - Disconnect power to unit.
- 2 - Remove lead between sensing electrode and ignition control. Install a microamp meter in series between the sensing electrode and the control. See figure 34.
- 3 - Reconnect power and adjust thermostat for heating demand.
- 4 - See table 14 after flame is established for meter reading. Do not bend electrodes.
- 5 - If the meter scale reads 0, the leads are reversed. Disconnect power and reconnect leads for proper polarity.
- 6 - When finished, disconnect power to unit before disconnecting meter. Make sure sensor wire is securely reconnected before reconnecting power to unit.

TABLE 14

Manufacturer	Nominal Signal Microamps	Drop Out
JOHNSON	0.5-1.0	.09
FENWALL	8-20	3

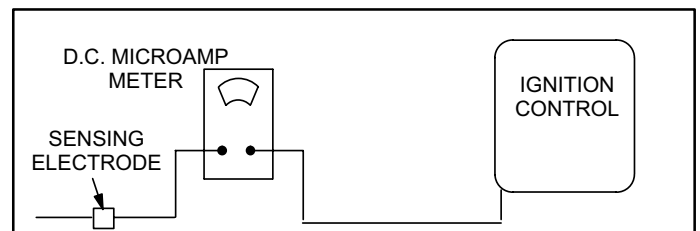

FIGURE 34

X-MAINTENANCE

Units should be inspected yearly by a qualified service technician.

! WARNING	
	<p>Electric shock hazard and danger of explosion. Can cause injury, death or product or property damage. Turn off gas and electrical power to unit before performing any maintenance or servicing operations on the unit. Follow lighting instructions attached to unit when putting unit back into operation and after service or maintenance.</p>

! CAUTION	
<p>Danger of sharp metallic edges. Can cause injury. Take care when servicing unit to avoid accidental contact with sharp edges.</p>	

A-Lubrication

All motor bearings are prelubricated. No further lubrication is required.

B-Filters

Unit is equipped with four pleated throw-away type filters. Filters should be checked and replaced when necessary with filters of like kind and size. Simply remove filter access panel and slide filters up. See table 15 for quantity and size. Take note of air flow direction marking on filter frame when reinstalling filters.

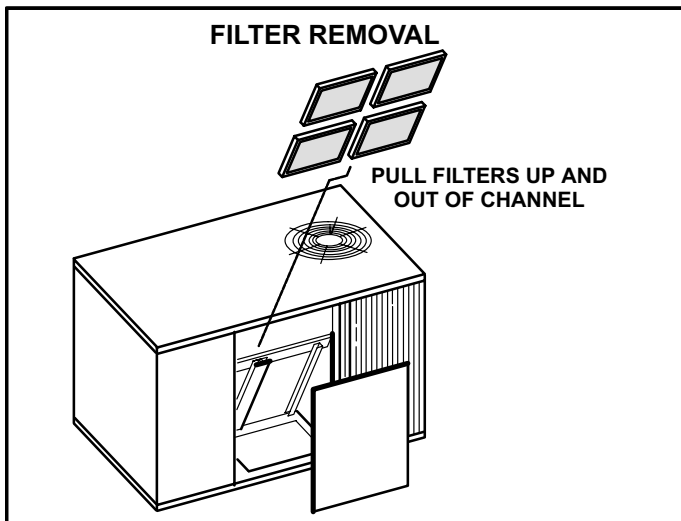

FIGURE 35

NOTE-Filters must be U.L.C. certified or equivalent for use in Canada.

TABLE 15

Unit	Quantity	Size"
-072/090	4	16 x 20 x 2
-120	2	16 x 20 x 2
		16 x 25 x 2
-150	2	20 x 20 x 2
		20 x 25 x 2

C-Burners (GCS models only)

- 1- Periodically examine burner flames for proper appearance during the heating season. Use inspection port in the front of the burner compartment access panel.
- 2- Before each heating season examine the burners for any deposits or blockage which may have occurred.
- 3- Clean burners as follows:
 - a- Turn off both electrical power and gas supply to unit.
 - b- Remove access panel to burner compartment.
 - c- Remove burner retaining clip and lift burners from orifice.
 - d- Clean as necessary and replace burners. Refit retaining clips. Make sure that burner heads line up correctly. Spark gaps on ignition and flame sensing electrode must be properly set. See HEATING COMPONENTS section for correct gap. Replace access panel.

! WARNING	
	<p>Danger of explosion. Can cause injury or death. Do not overtighten main burner mounting screws. Snug tighten only.</p>

- e- Restore electrical power and gas supply. Follow lighting instructions attached to unit and use inspection port in access panel to check flame.

D-Combustion Air Inducer (GCS models only)

Combustion air inducer proving switch S18 checks combustion air inducer operation before allowing power to the gas controller. Gas controller will not operate if inducer is obstructed.

Under normal operating conditions, the combustion air inducer wheel should be checked and cleaned prior to the heating season. However, it should be examined periodically during the heating season to establish an ideal cleaning schedule. With power supply disconnected, the condition of the blower wheel can be determined by looking through the vent opening.

Cleaning combustion air Inducer and Vent Cap

- 1- Shut off power supply and gas to unit.
- 2- Remove four screws retaining vent cap to side of unit. Clean vent cap as necessary.
- 3- Remove screws holding combustion air inducer to flue box and vent connector. Take care not to lose or damage vent screen.
- 4- Clean blower wheel blades with a small brush and wipe off any dust from housing. Clean accumulated dust from front of flue box.
- 5- Replace combustion air inducer motor by reversing this procedure. It is recommended that the combustion air inducer gasket be replaced during reassembly.
- 6- Clean louvers in combustion air supply (right side of heat section) using a small brush.

E-Flue Passageway and Flue Box (GCS Models only)

- 1- Remove combustion air inducer assembly as described in section D.
- 2- Remove flue box cover and flue tube collector plate. Clean with a wire brush as required.
- 3- Pull tube baffles from heat exchanger tubes and clean tubes with a wire brush.
- 4- Reinsert tube baffles and reassemble the unit. The flue box cover gasket and combustion air inducer gasket should also be replaced during reassembly.

F-Evaporator Coil

Inspect and clean coil at beginning of each cooling and heating season. Clean using mild detergent or commercial coil cleanser. Flush coil and condensate drain with water taking care not to get insulation, filters and return air ducts wet.

G-Condenser Coil

Clean condenser coil annually with detergent or commercial coil cleaner and inspect monthly during the cooling season.

IMPORTANT

If owner complains of insufficient cooling, unit should be gauged and refrigerant charge checked. Refer to gauge manifold attachment, checking charge and charging sections in this instructions.

H-Supply Air Blower Wheel

Annually inspect supply air blower wheel for accumulated dirt or dust. Turn off power before attempting to remove access panel or to clean blower wheel.

I-Electrical

- 1 - Check all wiring for loose connections.
- 2 - Check for correct voltage at unit (unit operating).
- 3 - Check amp-draw on both condenser fan motor and blower motor.

Fan Motor Rating Plate _____ Actual _____
Indoor Blower Motor Rating Plate _____ Actual _____

XI-ACCESSORIES

1-RMF16 Mounting Frame

When installing a GCS16 unit on a combustible surface for downflow discharge applications, RMF16 roof mounting (figure 36) frame is required. Otherwise, the RMF16 is recommended but not required. The GCS16, if not mounted on a flat (roof) surface, **MUST** be supported under all edges and under the middle of the unit to prevent sagging. The GCS16 **MUST** be mounted level within 1/16" per linear foot in any direction.

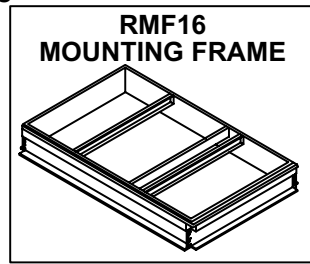

FIGURE 36

The assembled RMF16 mounting frame is shown in figure 36. Refer to the RMF16 installation instructions for details of proper assembly and mounting. Roof mounting frame **MUST** be squared to roof before mounting. Plenum system **MUST** be installed before unit is set on mounting frame. Refer to RMF16 installation instructions for proper plenum construction.

Many types of roof framing or supports can be used to mount the GCS16 unit, depending upon different roof structures.

2-REMD16M Downflow Economizer

The REMD16M economizers (figure 37) open a set of dampers to allow 0 to 100 percent outdoor air to be used for cooling when outdoor humidity and temperature are acceptable. Additional (2nd stage) cooling demand is directed to the compressor while the dampers remain open. If outdoor air becomes unacceptable, the outdoor air dampers close to a predetermined minimum position while the compressor cooling circuit cycles as needed.

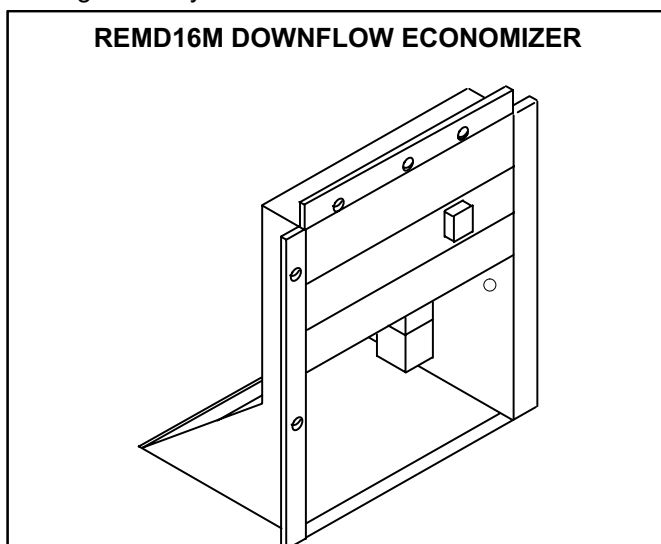

FIGURE 37

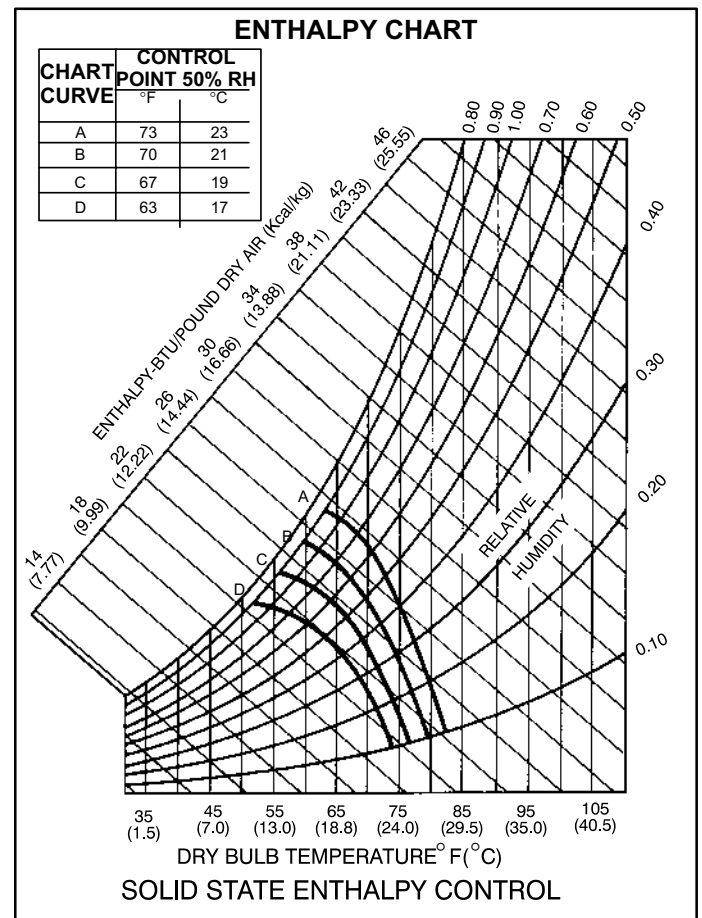

FIGURE 38

Economizer Operation

a-Enthalpy Control: Setpoint Control

The key to economizer operation is the enthalpy control. The enthalpy control senses the total heat content of the outside air (temperature plus humidity) and uses that information to control the amount of outside air brought into the system. When the enthalpy of outside air is below the control setpoint, the control actuates a motor which in turn adjusts the outdoor dampers to meet the cooling demands of the building.

When the heat content rises above the control setpoint, the control de-activates and the dampers close to the preset minimum position (not closed) position.

Two types of adjustment may be made at the control. The first is the control setpoint. The setpoint determines the temperature and humidity conditions at which the outdoor air dampers will open and close. The recommended setpoint is "A." If the economizer is allowing air which is too warm or too humid into the system, the control may be changed to a lower setpoint (B,C or D). Refer to enthalpy chart figure 38.

Example:

If the enthalpy control is set at setpoint "A" as shown in figure 38, the following situation could occur. A cooling demand when the outside air is at 75° and 20 percent humidity would drive the economizer outdoor air dampers open to utilize outdoor air for cooling. The compressor cooling circuit would be disabled. However, if the outdoor air should change to 70°F (a drop in temperature) and 70 percent humidity (a dramatic rise in humidity), the "total heat content" of the outdoor air would rise above the enthalpy control setpoint and de-activate the damper motor to the preset minimum position. If cooling demand is still present when the total heat of the outside air rises above the control setpoint, cooling demand is routed from the economizer to the compressor cooling circuit.

b-Minimum Position

The second type of adjustment which may be made at the control is the minimum position of the outdoor damper blades. Each economizer has a minimum position switch (potentiometer) which allows the outdoor dampers to be adjusted to a preset minimum position. This allows a preset amount of air exchange at all times during unit operation. When unit operation stops, the dampers drive fully closed. The potentiometer is located on the enthalpy control face (modulating economizer).

c-Enthalpy Sensor

The enthalpy sensor is located on the outside portion of the outdoor damper blades (as shown in figure 39). The sensor monitors the total heat content of the outdoor air (temperature plus humidity) and sends the information to the enthalpy control. The enthalpy control uses the information to determine if outdoor air can be used for cooling.

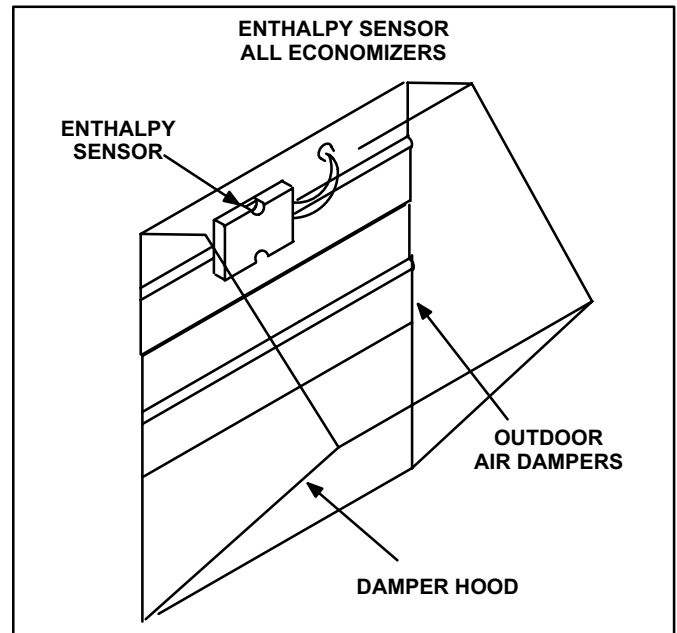

FIGURE 39

d-Mixed Air Sensor

The sensor measures the resultant temperature of the mixed air downstream of the evaporator coil. The mixed air temperature is used by the enthalpy control when outdoor dampers are open to help determine whether outdoor air dampers should close. Modulating economizers are equipped with a single mixed air sensor.

The mixed air sensor (bulb) is located in the supply air stream. The sensor (modulating economizer) fits through a factory supplied hole in the panel dividing the unit return and supply air.

e-Modulating Damper Motor Check

Honeywell W7459A

- 1 - Disconnect main power to the GCS16.
- 2 - Turn thermostat control to OFF position (occupied mode).
- 3 - Install jumper across terminals 6-9 on blower relay in unit control box.
- 4 - Install jumper across enthalpy control terminals T and T1. See figure 40 for location.
- 5 - Restore power to unit. Outdoor damper should drive to fully open position (60 to 90 sec. required for full travel). Observe travel for proper damper operation.
- 6 - Disconnect power to the unit. Outdoor damper should spring return to closed position.
- 7 - Remove T and T1 jumper then restore power to the unit. Outdoor damper should drive to minimum position. Adjust minimum damper position pot located on control. See figure 40.
- 8 - Disconnect power to unit and remove jumper on blower relay terminals 6-9. Replace all panels. Restore power to unit.

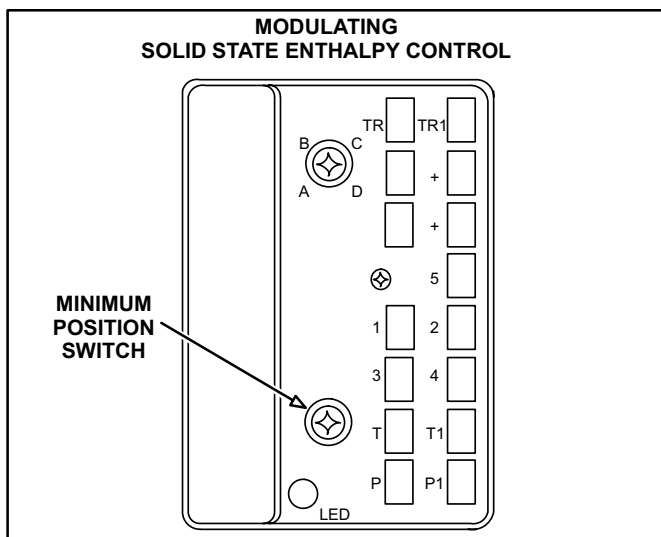

FIGURE 40

f-Warm Up Kit

An optional warm up kit may be added to either REMD16 or EMDH16 economizer (except GCS16s using a Honeywell W7400 Control System). The warm up kit holds the dampers closed during night setback and morning warm up. When the first thermostat demand of the day is satisfied, the warm up kit opens the outdoor dampers to minimum position. The warm up kit mounts to the GCS16 in the control mounting area of the blower compartment. The kit plugs into the unit wiring harness inline between the unit and the economizer.

g-Night Relay

Optional night relay must be added to economizer when night setback functions are desired with W973 or electromechanical control systems. Kit includes a DPDT relay which is hard-wired to the economizer harness.

If a W973 system is used, the relay holds the outdoor dampers closed during setback. If an electromechanical thermostat system is used, the relay holds the outdoor dampers closed during setback, de-energizes the indoor thermostat and energizes the setback thermostat. Night relay is not required for any other control system.

3-OAD16 Outdoor Air Damper

OAD16 damper section (figure 41) may be installed any place outside of the building in the return air duct for horizontal applications and in the return air panel for downflow applications. Refer to OAD16 installation instruction manual for specific details regarding installation. The OAD16 damper motor kit (35G21) provides motorized operation of air damper blades. The washable filter supplied with the OAD16 can be cleaned with water and mild detergent. It should be sprayed with Filter Handicoater when dry prior to reinstallation. Filter Handicoater is R.P. Products coating no. 418 and is available as Lennox Part No. P-8-5069 (30165).

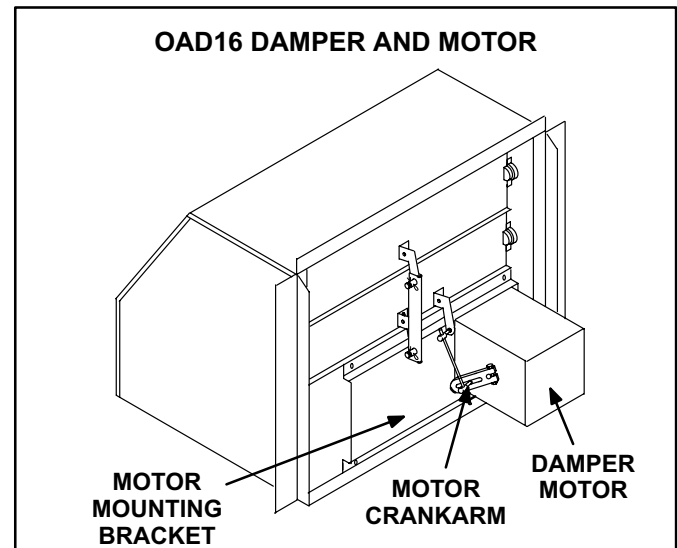

FIGURE 41

4-LPG Kit

All A.G.A rated GCS16s are factory set for use with natural gas. An optional L.P.G. conversion kit allows changeover from natural to L.P.G. supply. The kit includes a gas valve changeover kit and new gas orifice. GCS16-090-1 models will have 7/16-27 straight thread gas orifices. GCS16-072, GCS16-090-2 and GCS16120/150 models will have 1/8 NPT pipe thread gas orifices.

Refer to the L.P.G. conversion kit installation instruction for specific installation procedures.

5-Condenser Coil Guard Kit

Optional condenser coil guard kit is available for all units. The kit includes PVC coated steel wire coil guard which is field installed.

6-Low Ambient Kit

The optional low ambient kit (figure 42) allows for mechanical cooling operation down to 0°F (17.7°C)

⚠ CAUTION

Compressor monitor cannot be used with optional low ambient kit. Optional field installed compressor monitor MUST be disconnected before allowing low ambient kit to be used.

The low ambient pressure switch is wired in series with the condenser fan L1 lead on the GCS16-072 model and with the K10 condenser fan relay on GSC16-090/120/150 models. Refer to the low ambient kit installation instruction manual for detailed installation instructions.

The low ambient pressure switch cycles the condenser fan while allowing normal compressor operation. This intermittent fan operation results in a high evaporating temperature which allows the system to operate without evaporator coil icing and losing capacity.

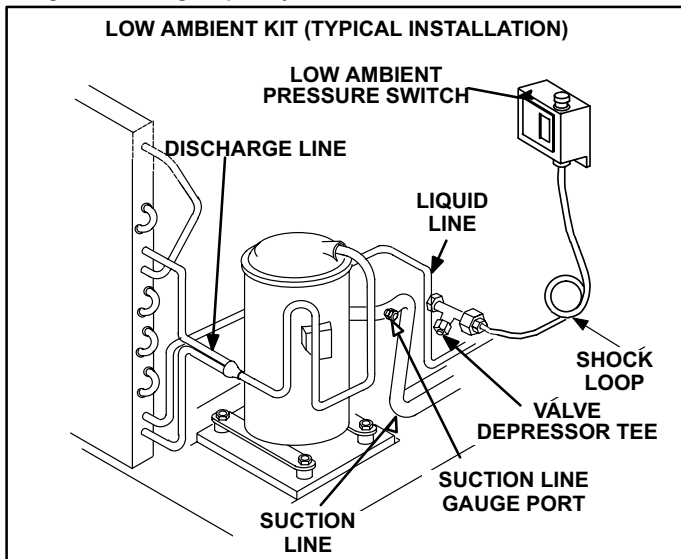

FIGURE 42

Adjustment:

The low ambient pressure switch is adjustable but the adjustment knob *does not* adjust CUT-IN point. CUT-IN point is fixed and cannot be adjusted. The scale on the switch measures the difference in pressure between preset CUT-IN and adjustable CUT-OUT points. Adjustment knob changes CUT-OUT point by adjusting the DIFFERENCE between CUT-IN and CUT-OUT.

The low ambient pressure switch is factory set to CUT-IN at 285psig with a difference of 145psig (CUT-OUT at 140psig). Adjustment should not be needed. If adjustment is needed, adjust the switch as follows:

- 1 - Loosen knob securing screw to allow knob stop to pass over fixed stop on control (see figure 43).

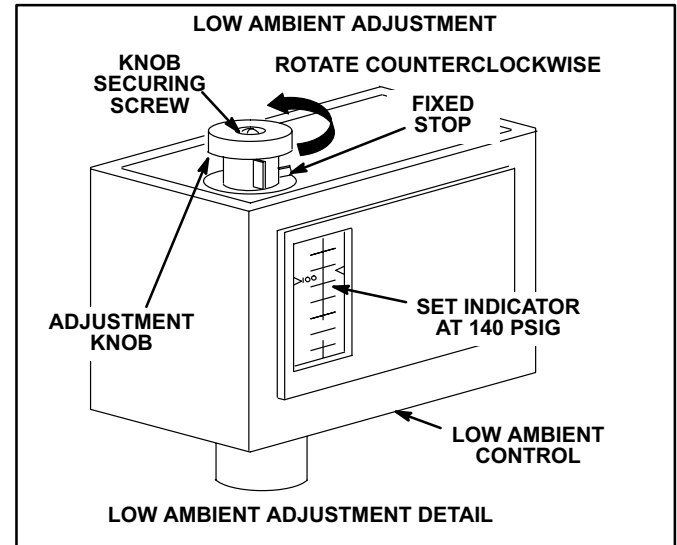

FIGURE 43

DIFFERENCE (set by knob) = CUT-IN POINT (fixed) minus CUT-OUT POINT

To find CUT-OUT point, this equation can be re-arranged:

CUT-OUT = CUT-IN minus the DIFFERENCE.

- 2 - Rotate the knob as needed to set the difference indicator at 145psig (1000kPa).
- 3 - Tighten the securing screw after adjusting.

7-Transitions

Optional supply/return transitions (SRT16) are available for use with downflow GCS16s utilizing the optional RMF16 roof mounting frame and supply/return diffusers. The transition must be installed in the RMF16 mounting frame before mounting the GCS16 to the frame. Refer to the manufacturer's instructions included with the transition for detailed installation procedures.

8-Supply and Return Diffusers

Optional flush mount supply/return diffusers FD11-95 and FD11-135 and extended mount supply/return diffusers RTD11-95 and RTD11-135 are available for use with the GCS16. Refer to the manufacturer's instructions included with the transition for detailed installation procedures.

XII-WIRING DIAGRAMS AND SEQUENCE OF OPERAITON

GCS16-072 WIRING DIAGRAM

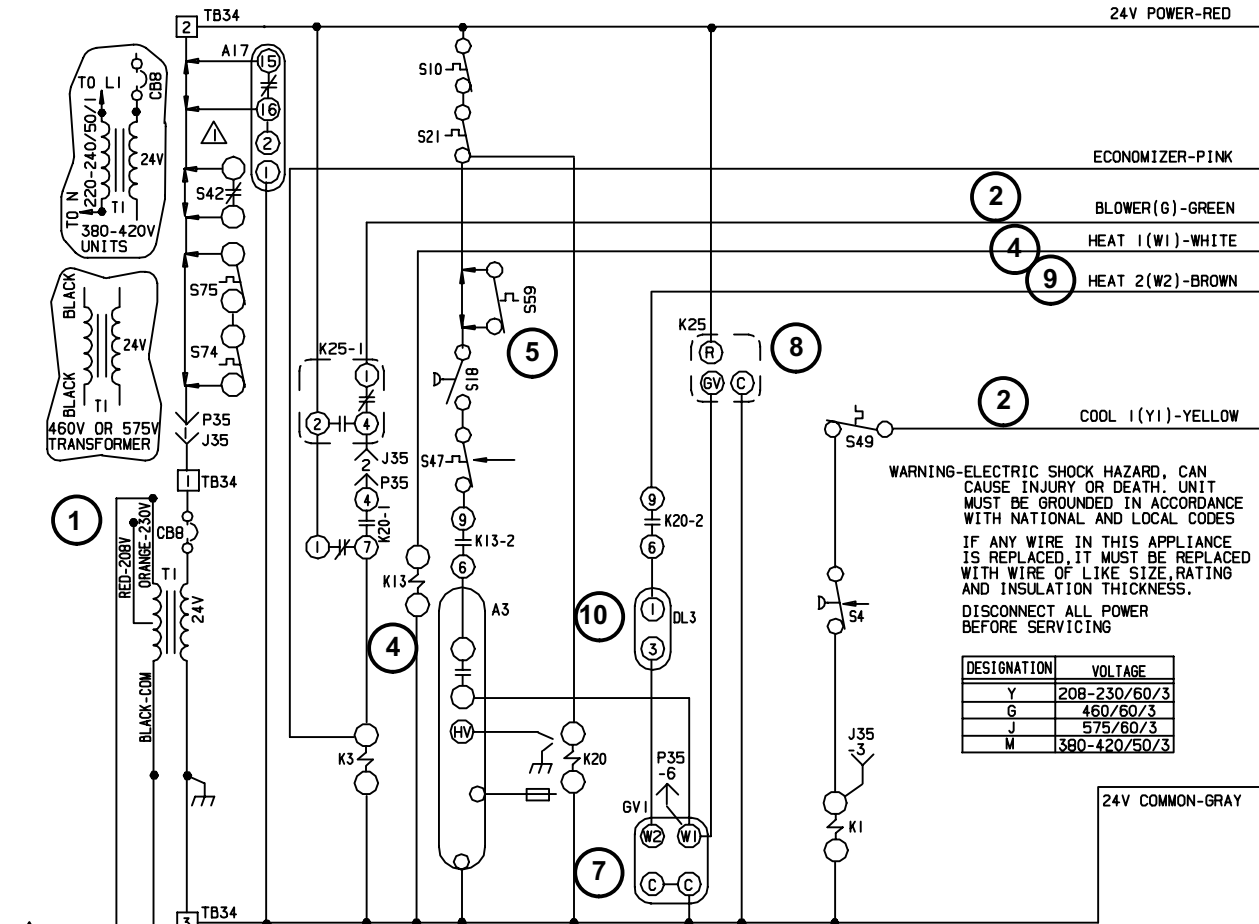

WARNING-ELECTRIC SHOCK HAZARD, CAN CAUSE INJURY OR DEATH. UNIT MUST BE GROUNDED IN ACCORDANCE WITH NATIONAL AND LOCAL CODES

IF ANY WIRE IN THIS APPLIANCE IS REPLACED, IT MUST BE REPLACED WITH WIRE OF LIKE SIZE, RATING AND INSULATION THICKNESS.

DISCONNECT ALL POWER BEFORE SERVICING

DESIGNATION	VOLTAGE
Y	208-230/60/3
G	460/60/3
J	575/60/3
M	380-420/50/3

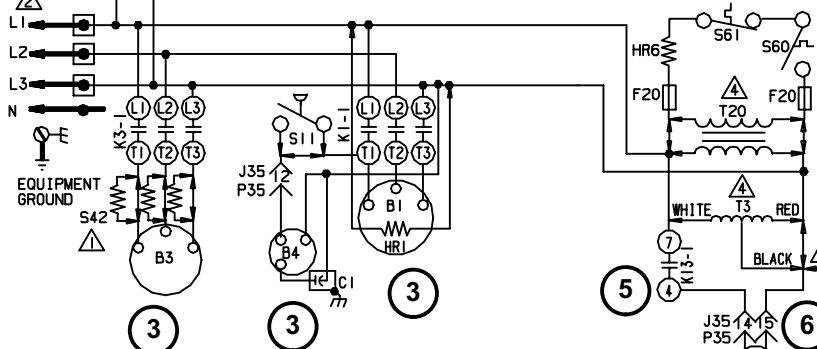

KEY	DESCRIPTION
S60	THERMOSTAT, -23°C CLOSE, -7°C OPEN, -50°C
S61	THERMOSTAT, +24°C OPEN, -50°C
S74	SWITCH-FIRESTAT 1
S75	SWITCH-FIRESTAT 2
T1	TRANSFORMER-CONTROL
T3	TRANSFORMER-COMB AIR BLOWER
T20	TRANSFORMER, -50°C LOW AMBIENT KIT
TB34	TERMINAL STRIP-TRANSFORMER T1

- △ USED ON "M" VOLTAGE UNITS ONLY
- △ FOR USE WITH COPPER CONDUCTORS ONLY REFER TO UNIT RATING PLATE FOR MINIMUM CIRCUIT AMPACITY AND MAXIMUM OVERCURRENT PROTECTION SIZE
- △ -50°C LOW AMBIENT CONTROL, CGA UNITS ONLY
- △ T20 & T3 USED ON 460V & 575V UNITS ONLY
- ← INDICATES OPTIONAL COMPONENTS
- LINE VOLTAGE FIELD INSTALLED

KEY	DESCRIPTION
A3	CONTROL-BURNER
A17	DETECTOR-SMOKE
B1	COMPRESSOR
B3	MOTOR-BLOWER
B4	MOTOR-COND FAN 1
B6	MOTOR-COMB AIR BLOWER
C1	CAPACITOR-COND FAN 2
C3	CAPACITOR-COMB AIR BLOWER
CBB	CIRCUIT BREAKER-TRANS T1
DL3	DELAY-GAS 2(180SEC)
F20	FUSE, -50°C LOW AMBIENT KIT
GV1	VALVE-GAS
K1	CONTACTOR-COMPRESSOR 1
HR1	HEATER-COMPRESSOR 1
HR6	HEATER, -50°C LOW AMB KIT
J35	JACK-TEST, COOL

KEY	DESCRIPTION
K1	CONTACTOR-COMPRESSOR 1
K3	CONTACTOR-BLOWER
K13	RELAY-COMB AIR BLOWER
K20	RELAY-LIMIT, BLOWER
K25	RELAY-BLOWER DELAY
P35	PLUG-TEST, COOL
S4	SWITCH-LIMIT, HI PRESS COMP 1
S10	SWITCH-LIMIT, PRIMARY
S11	SWITCH-LOW PRESS, LOW AMB KIT
S18	SWITCH-COMB AIR BLOWER, PROVE
S21	SWITCH-LIMIT, SECONDARY
S42	SWITCH-OVERLOAD
S47	SWITCH-FLAME ROLLOUT
S49	SWITCH-FREEZESTAT COMP 1
S59	THERMOSTAT, -35°C OPEN, -50°C

WIRING DIAGRAM 9/99	
COMBINATION UNITS-ROOFTOP	
GCS16-072-1-G, J, M, Y	
HEAT, COOL SECTION B2	
Supersedes Form No. 533, 090W	New Form No. 533, 304W
© 1999	Litho U.S.A.

GCS16-072 SEQUENCE OF OPERATION

Operation Sequence

Cooling:

- 1- Line voltage energizes transformer T1. Transformer T1 provides 24VAC power to all unit controls and thermostat.
- 2- Cooling demand energizes Y1 and G in the thermostat. K3 blower relay is energized. Voltage passes through S49 freeze stat then S4 high pressure switch, to energize K1 compressor contactor (assuming liquid line pressure is high enough to close S11 low ambient kit).
- 3- K1-1 closes to energize compressor and condenser fan. Compressor B1 and condenser fan B4 immediately begin operating. Simultaneously K3-1 contacts close energizing indoor blower B3 and economizer (if used).

Heating: 1st Stage

- 4- Heating demand initiates at W1 in the thermostat and energizes relay K13.
- 5- K13-1 contacts close energizing combustion air inducer B6. When the induced draft nears full speed, prove switch S18 closes. Heating demand continues through S18, S10 primary limit, S21 secondary limit and flame rollout switch S47 to energize ignition control A3.

6- Ignition control A3 then waits 30 to 40 seconds to allow combustion air inducer B6 time to draw exhaust gas from combustion chamber and to introduce fresh air. Combustion air inducer B6 operates throughout the heating cycle.

7- After the ignition control delay, A3 activates gas valve GV1 and the spark electrode. When flame is sensed by the flame sensor (minimum 5 microamps) the spark electrode stops. If flame is not sensed after the first trial for ignition, controller A3 repeats steps 6 and 7 up to two more times (depending on controller make) before locking out. If the control locks out, it can be reset by breaking and remaking thermostat demand.

8- Blower delay relay K25 energizes blower B3 after 45 second delay.

Heating: 2nd. Stage

9- With first stage operating, an additional heating demand initiates W2 in the thermostat.

10- DL3 energizes gas valve GV1 after 180 second delay. Unit operates at full heating capacity.

TYPICAL GCS16-090-1 WIRING DIAGRAM

24V POWER-RED

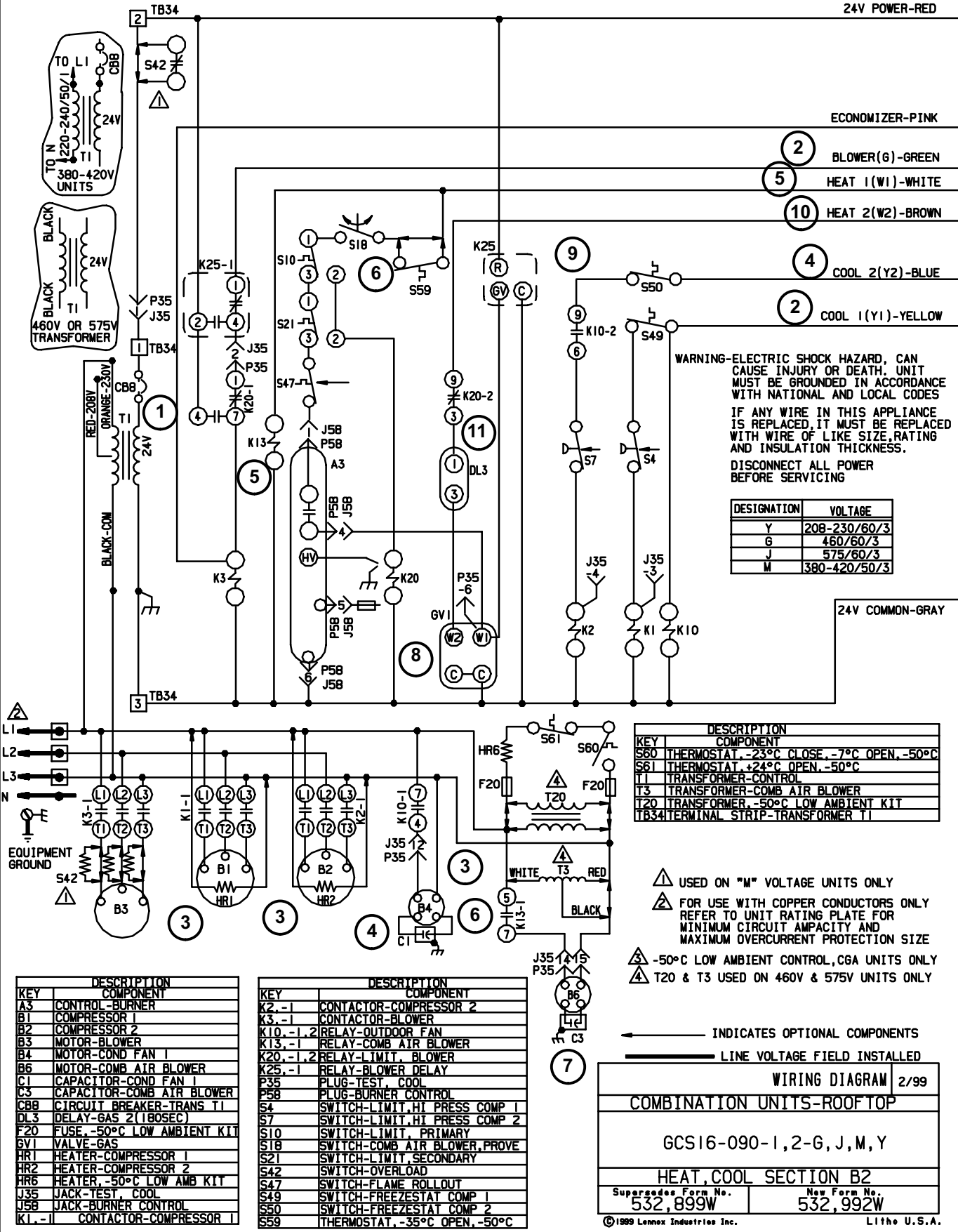

ECONOMIZER-PINK

- 2 BLOWER(G)-GREEN
- 5 HEAT 1(W1)-WHITE
- 10 HEAT 2(W2)-BROWN
- 4 COOL 2(Y2)-BLUE
- 2 COOL 1(Y1)-YELLOW

WARNING-ELECTRIC SHOCK HAZARD, CAN CAUSE INJURY OR DEATH. UNIT MUST BE GROUNDED IN ACCORDANCE WITH NATIONAL AND LOCAL CODES

IF ANY WIRE IN THIS APPLIANCE IS REPLACED, IT MUST BE REPLACED WITH WIRE OF LIKE SIZE, RATING AND INSULATION THICKNESS. DISCONNECT ALL POWER BEFORE SERVICING

DESIGNATION	VOLTAGE
Y	208-230/60/3
G	460/60/3
J	575/60/3
M	380-420/50/3

24V COMMON-GRAY

KEY	DESCRIPTION
KEY	COMPONENT
S60	THERMOSTAT, -23°C CLOSE, -7°C OPEN, -50°C
S61	THERMOSTAT +24°C OPEN, -50°C
T1	TRANSFORMER-CONTROL
T3	TRANSFORMER-COMB AIR BLOWER
T20	TRANSFORMER, -50°C LOW AMBIENT KIT
TB34	TERMINAL STRIP-TRANSFORMER T1

- ⚠ USED ON "M" VOLTAGE UNITS ONLY
- ⚠ FOR USE WITH COPPER CONDUCTORS ONLY REFER TO UNIT RATING PLATE FOR MINIMUM CIRCUIT AMPACITY AND MAXIMUM OVERCURRENT PROTECTION SIZE
- ⚠ -50°C LOW AMBIENT CONTROL, CGA UNITS ONLY
- ⚠ T20 & T3 USED ON 460V & 575V UNITS ONLY

← INDICATES OPTIONAL COMPONENTS
 — LINE VOLTAGE FIELD INSTALLED

KEY	DESCRIPTION
A3	CONTROL-BURNER
B1	COMPRESSOR 1
B2	COMPRESSOR 2
B3	MOTOR-BLOWER
B4	MOTOR-COND FAN 1
B6	MOTOR-COMB AIR BLOWER
C1	CAPACITOR-COND FAN 1
C3	CAPACITOR-COMB AIR BLOWER
CBB	CIRCUIT BREAKER-TRANS T1
DL3	DELAY-GAS Z(180SEC)
F20	FUSE, -50°C LOW AMBIENT KIT
GV1	VALVE-GAS
H1	HEATER-COMPRESSOR 1
H2	HEATER-COMPRESSOR 2
HR6	HEATER, -50°C LOW AMB KIT
J35	JACK-TEST, COOL
J58	JACK-BURNER CONTROL
K1, -1	CONTACTOR-COMPRESSOR 1

KEY	DESCRIPTION
K2, -1	CONTACTOR-COMPRESSOR 2
K3, -1	CONTACTOR-BLOWER
K10, -1, 2	RELAY-OUTDOOR FAN
K13, -1	RELAY-COMB AIR BLOWER
K20, -1, 2	RELAY-LIMIT, BLOWER
K25, -1	RELAY-BLOWER DELAY
P35	PLUG-TEST, COOL
P58	PLUG-BURNER CONTROL
S4	SWITCH-LIMIT, HI PRESS COMP 1
S7	SWITCH-LIMIT, HI PRESS COMP 2
S10	SWITCH-LIMIT, PRIMARY
S18	SWITCH-COMB AIR BLOWER, PROVE
S21	SWITCH-LIMIT, SECONDARY
S42	SWITCH-OVERLOAD
S47	SWITCH-FLAME ROLLOUT
S49	SWITCH-FREEZESTAT COMP 1
S50	SWITCH-FREEZESTAT COMP 2
S59	THERMOSTAT, -35°C OPEN, -50°C

WIRING DIAGRAM	2/99
COMBINATION UNITS-ROOFTOP	
GCS16-090-1, 2-G, J, M, Y	
HEAT, COOL SECTION B2	
Supersedes Form No. 532, 899W	New Form No. 532, 992W
©1989 Lennox Industries Inc.	Litho U.S.A.

TYPICAL GCS16-090-2 WIRING DIAGRAM

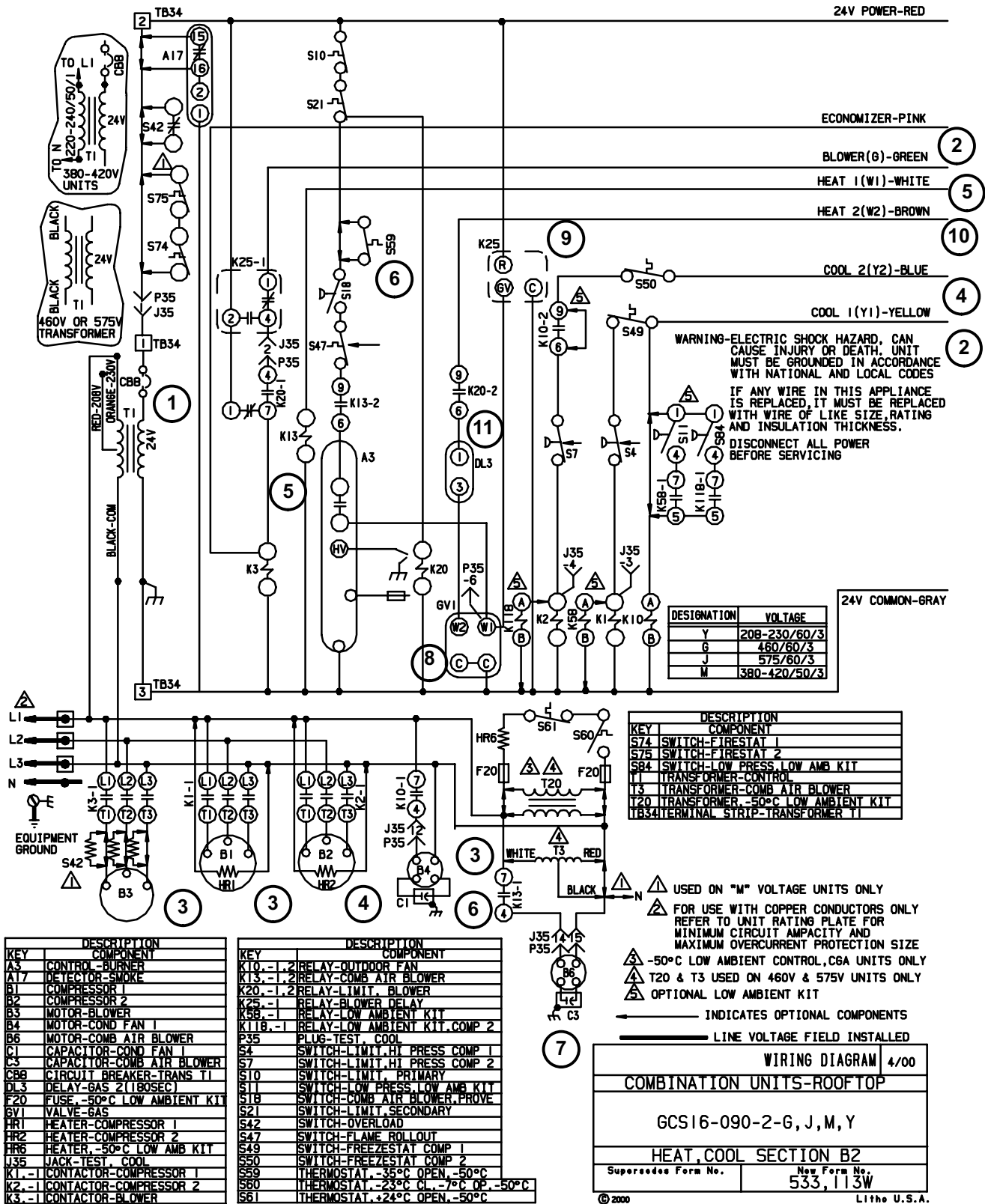

GCS16-090-1 and -2 SEQUENCE OF OPERATION

Operation Sequence

Cooling: 1st. Stage

- 1- Line voltage energizes transformer T1. Transformer T1 provides 24VAC power to all unit controls and thermostat.
- 2- Cooling demand energizes Y1 and G in the thermostat. K3 blower relay is energized. Voltage passes through optional components S11 low ambient pressure switch and K58 low ambient relay, or S84 low ambient pressure switch and K118 low ambient relay, (assuming the liquid line pressure is high enough) to energize K10 condenser fan relay. Simultaneously voltage passes through S49 freestat then S4 high pressure switch, to energize K1 compressor contactor.
- 3- K1-1 closes to energize compressor and K10-1 closes to energize condenser fan. Compressor B1 and condenser fan B4 immediately begin operating. Simultaneously K3-1 contacts close energizing indoor blower B3 and economizer (if used).

Cooling: 2nd. Stage

- 4- Cooling demand energizes Y2 in the thermostat. Voltage passes through S50 freestat, K10 condenser fan relay, and S7 high pressure switch to energize K2 compressor contactor. K2-1 contacts close energizing compressor B2.

Heating: 1st Stage

- 5- Heating demand initiates at W1 in the thermostat and energizes combustion air inducer relay K13.
 - 6- K13-1 contacts close energizing combustion air inducer B6. Economizer is also energized. When the combustion air inducer nears full speed, prove switch S18 closes. Heating demand continues through S18, S10 primary limit, S21 secondary limit and flame rollout switch S47 to energize ignition control A3.
 - 7- Ignition control A3 then waits 30 to 40 seconds to allow combustion air inducer B6 time to draw exhaust gas from combustion chamber and to introduce fresh air. Combustion air inducer B6 operates throughout the heating cycle.
 - 8- After the ignition control delay, A3 activates gas valve GV1 and the spark electrode. When flame is sensed by the flame sensor (minimum 5 microamps) the spark electrode stops. If flame is not sensed after the first trial for ignition, controller A3 repeats steps 7 and 8 up to two more times (depending on controller make) before locking out. If the control locks out, it can be reset by breaking and remaking thermostat demand.
 - 9- Blower delay relay K25 energizes blower B3 after 45 second delay.
- #### Heating: 2nd. Stage
- 10- With first stage operating, an additional heating demand initiates W2 in the thermostat.
 - 11- DL3 energizes gas valve GV1 after 180 second delay. Unit operates at full heating capacity.

GCS16-120/150 WIRING DIAGRAM

24V POWER-RED

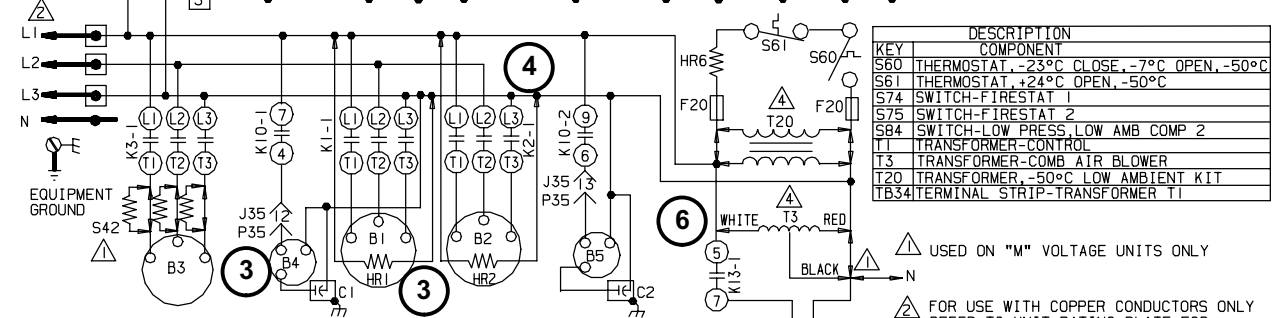
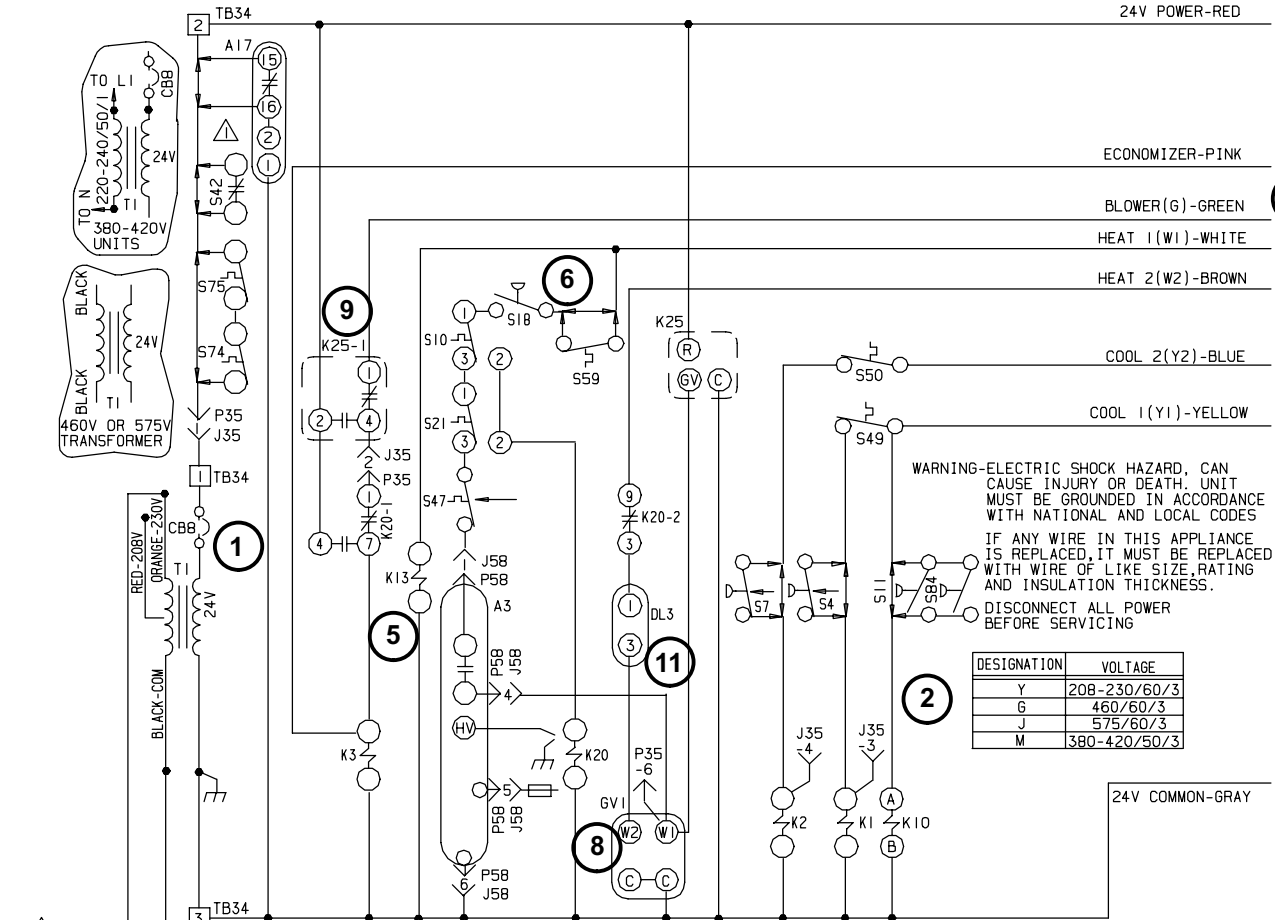

KEY	DESCRIPTION	COMPONENT
A3	CONTROL-BURNER	
A17	DETECTOR-SMOKE	
B1	COMPRESSOR 1	
B2	COMPRESSOR 2	
B3	MOTOR-BLOWER	
B4	MOTOR-COND FAN 1	
B5	MOTOR-COND FAN 2	
B6	MOTOR-COMB AIR BLOWER	
C1	CAPACITOR-COND FAN 1	
C2	CAPACITOR-COND FAN 2	
C3	CAPACITOR-COMB AIR BLOWER	
CBB	CIRCUIT BREAKER-TRANS T1	
DL3	DELAY-GAS 2(1B0SEC)	
F20	FUSE, -50°C LOW AMBIENT KIT	
GV1	VALVE-GAS	
HR1	HEATER-COMPRESSOR 1	
HR2	HEATER-COMPRESSOR 2	
HR6	HEATER, -50°C LOW AMB KIT	
J35	JACK-TEST, COOL	
J58	JACK-BURNER CONTROL	

KEY	DESCRIPTION	COMPONENT
K1, -1	CONTACTOR-COMPRESSOR 1	
K2, -1	CONTACTOR-COMPRESSOR 2	
K3, -1	CONTACTOR-BLOWER	
K10, -1, 2	RELAY-OUTDOOR FAN	
K13, -1	RELAY-COMB AIR BLOWER	
K20, -1, 2	RELAY-LIMIT, BLOWER	
K25, -1	RELAY-BLOWER DELAY	
P35	PLUG-TEST, COOL	
P58	PLUG-BURNER CONTROL	
S4	SWITCH-LIMIT, HI PRESS COMP 1	
S7	SWITCH-LIMIT, HI PRESS COMP 2	
S10	SWITCH-LIMIT, PRIMARY	
S11	SWITCH-LOW PRESS, LOW AMB KIT	
S18	SWITCH-COMB AIR BLOWER, PROVE	
S21	SWITCH-LIMIT, SECONDARY	
S42	SWITCH-OVERLOAD	
S47	SWITCH-FLAME ROLLOUT	
S49	SWITCH-FREEZESTAT COMP 1	
S50	SWITCH-FREEZESTAT COMP 2	
S59	THERMOSTAT, -35°C OPEN, -50°C	

KEY	DESCRIPTION	COMPONENT
S60	THERMOSTAT, -23°C CLOSE, -7°C OPEN, -50°C	
S61	THERMOSTAT, -24°C OPEN, -50°C	
S74	SWITCH-FIRESTAT 1	
S75	SWITCH-FIRESTAT 2	
S84	SWITCH-LOW PRESS, LOW AMB COMP 2	
T1	TRANSFORMER-CONTROL	
T3	TRANSFORMER-COMB AIR BLOWER	
T20	TRANSFORMER, -50°C LOW AMBIENT KIT	
TB34	TERMINAL STRIP-TRANSFORMER T1	

- ⚠ USED ON "M" VOLTAGE UNITS ONLY
- ⚡ FOR USE WITH COPPER CONDUCTORS ONLY REFER TO UNIT RATING PLATE FOR MINIMUM CIRCUIT AMPACITY AND MAXIMUM OVERCURRENT PROTECTION SIZE
- ⚡ -50°C LOW AMBIENT CONTROL, CGA UNITS ONLY
- ⚡ T20 & T3 USED ON 460V & 575V UNITS ONLY
- INDICATES OPTIONAL COMPONENTS
- LINE VOLTAGE FIELD INSTALLED

WIRING DIAGRAM	10/99
COMBINATION UNITS-ROOFTOP	
GCS16-120-2-G, J, M, Y	
GCS16-150-1-G, J, M, Y	
HEAT, COOL SECTION B2	
Supersedes Form No. 532,927W	New Form No. 533,091W

© 1999 Lennox Industries Inc. Litho U.S.A.

GCS16-120/150 SEQUENCE OF OPERATION

Operation Sequence

Cooling: 1st. Stage

- 1- Line voltage energizes transformer T1. Transformer T1 provides 24VAC power to all unit controls and thermostat.
- 2- Cooling demand energizes Y1 and G in the thermostat. K3 blower relay is energized. Simultaneously, voltage passes through S49 freezestat, optional low ambient kit S11 or S84 (assuming liquid line pressure is high enough) energizing K1 compressor contactor and K10 condenser fan relay.
- 3- K1-1 closes to energize compressor B1 and K10-1 and K10-2 close to energize condenser fans B4 and B5. Compressor B1 and condenser fans B4 and B5 immediately begin operating. Simultaneously K3-1 contacts close energizing indoor blower B3.

Cooling: 2nd. Stage

- 4- Cooling demand energizes Y2 in the thermostat. Voltage passes through S50 freezestat and optional S7 high pressure switch to energize K2 compressor contactor. K2-1 contacts close energizing compressor B2.

Heating: 1st Stage

- 5- Heating demand initiates at W1 in the thermostat and energizes combustion air relay K13.
- 6- K13-1 contacts close energizing combustion air inducer B6. Economizer is also energized. When the combustion air inducer nears full speed, prove switch S18 closes. Heating demand continues through S18, S10 primary limit, S21 secondary limit and flame rollout switch S47 to energize ignition control A3.
- 7- Ignition control A3 then waits 30 to 40 seconds to allow combustion air inducer B6 time to draw exhaust gas from combustion chamber and to introduce fresh air. Combustion air inducer B6 operates throughout the heating cycle.
- 8- After the ignition control delay, A3 activates gas valve GV1 and the spark electrode. When flame is sensed by the flame sensor (minimum 5 microamps) the spark electrode stops. If flame is not sensed after the first trial for ignition, controller A3 repeats steps 8 through 9 up to two more times (depending on controller make) before locking out. If the control locks out, it can be reset by breaking and remaking thermostat demand.
- 9- Blower delay relay K25 energizes blower relay K3 which in turn energizes blower B3 after 45 second delay.

Heating: 2nd. Stage

- 10- With first stage operating, an additional heating demand initiates W2 in the thermostat.
- 11- DL3 energizes gas valve GV1 after 180 second delay. Unit operates at full heating capacity.

CHA16-072 WIRING DIAGRAM

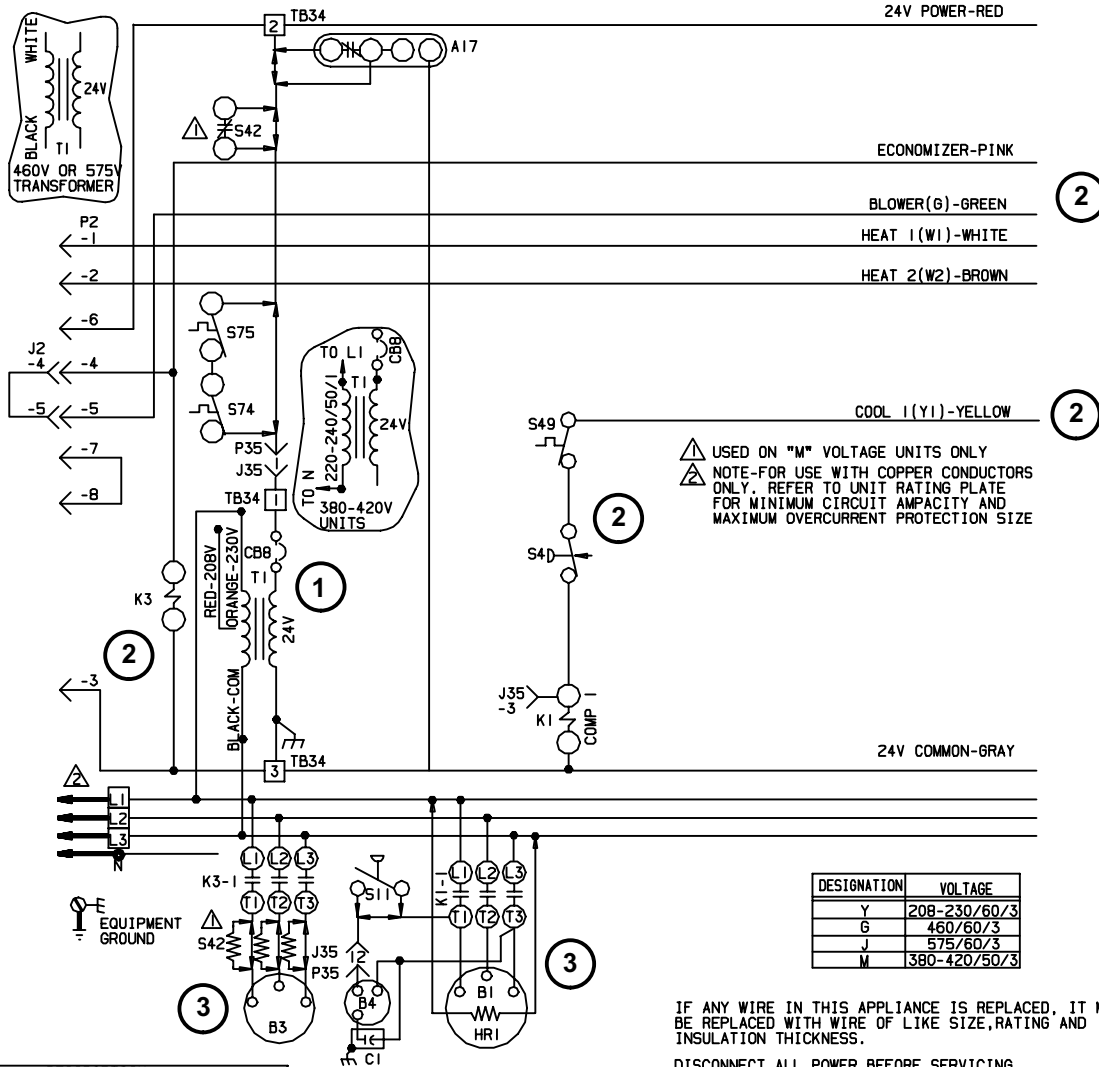

DESIGNATION	VOLTAGE
Y	208-230/60/3
G	460/60/3
J	575/60/3
M	380-420/50/3

IF ANY WIRE IN THIS APPLIANCE IS REPLACED, IT MUST BE REPLACED WITH WIRE OF LIKE SIZE, RATING AND INSULATION THICKNESS.

DISCONNECT ALL POWER BEFORE SERVICING

← DENOTES OPTIONAL COMPONENTS

WARNING-ELECTRIC SHOCK HAZARD, CAN CAUSE INJURY OR DEATH. UNIT MUST BE GROUNDED IN ACCORDANCE WITH NATIONAL AND LOCAL CODES

— LINE VOLTAGE FIELD INSTALLED

KEY	DESCRIPTION
A17	DETECTOR-SMOKE
B1	COMPRESSOR I
B3	MOTOR-BLOWER
B4	MOTOR-COND FAN I
C1	CAPACITOR-COND FAN I
CB8	CIRCUIT BREAKER-TRANSFORMER T1
HR1	HEATER-COMPRESSOR I
J2	JACK-UNIT, HEAT
J35	JACK-TEST, COOL
K1, -1	CONTACTOR-COMPRESSOR I
K3, -1	CONTACTOR-BLOWER
P2	PLUG-UNIT, HEAT
P35	PLUG-TEST, COOL
S4	SWITCH-LIMIT HI PRESS COMP I
S11	SWITCH-LOW PRESS, LOW AMB KIT
S42	SWITCH-OVERLOAD
S49	SWITCH-FREEZESTAT, COMP I
S74	SWITCH-FIRESTAT 1
S75	SWITCH-FIRESTAT 2
TB34	TERMINAL STRIP-TRANSFORMER T1
T1	TRANSFORMER-CONTROL

WIRING DIAGRAM		8/01
COOLING UNITS-PACKAGED		
CHA16-072-1-G, J, M, Y		
COOLING SECTION B2		
Supersedes Form No.	New Form No.	
	533, 098W	

© 2001 Litho U.S.A.

Operation Sequence

- 1- Line voltage energizes transformer T1. Transformer T1 provides 24VAC power to all unit controls and thermostat.
- 2- Cooling demand energizes Y1 and G in the thermostat. K3 blower relay is energized. Simultaneously, voltage passes through S49 freezestat, optional low ambient kit S11 or S84 (assuming liquid line pressure is high enough) energizing K1 compressor contactor and K10 condenser fan relay.
- 3- K1-1 closes to energize compressor B1 and K10-1 and K10-2 close to energize condenser fans B4 and B5. Compressor B1 and condenser fans B4 and B5 immediately begin operating. Simultaneously K3-1 contacts close energizing indoor blower B3.

CHA16-090 WIRING DIAGRAM

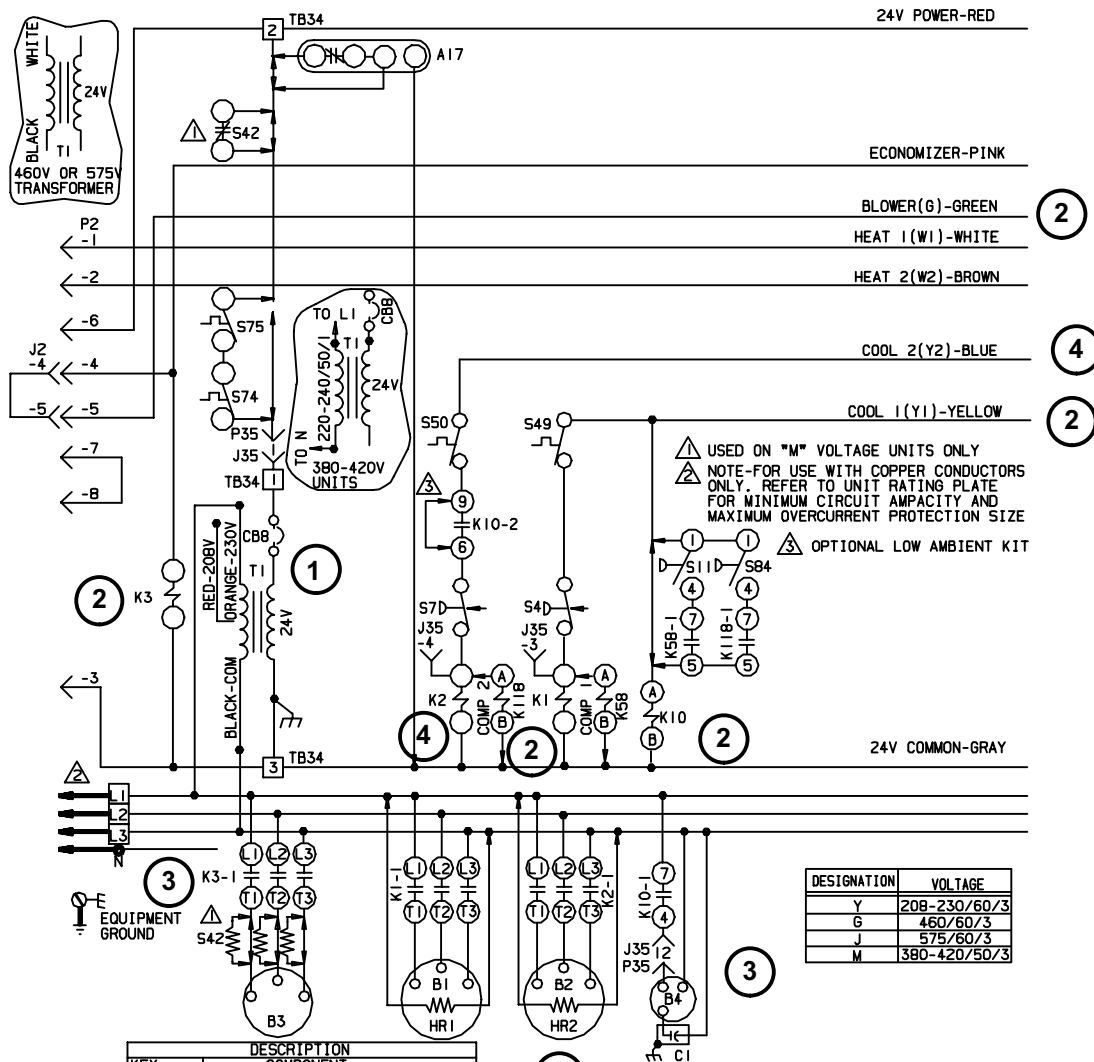

KEY	DESCRIPTION COMPONENT
A17	DETECTOR-SMOKE
B1	COMPRESSOR 1
B2	COMPRESSOR 2
B3	MOTOR-BLOWER
B4	MOTOR-COND FAN 1
C1	CAPACITOR-COND FAN 1
CB8	CIRCUIT BREAKER-TRANSFORMER T1
HR1	HEATER-COMPRESSOR 1
HR2	HEATER-COMPRESSOR 2
J2	JACK-UNIT, HEAT
J35	JACK-TEST, COOL
K1,-1	CONTACTOR-COMPRESSOR 1
K2,-1	CONTACTOR-COMPRESSOR 2
K3,-1	CONTACTOR-BLOWER
K10,-1,2	RELAY-OUTDOOR FAN
K58,-1	RELAY-LOW AMBIENT KIT
K118,-1	RELAY-LOW AMBIENT KIT,COMP 2
P2	PLUG-UNIT, HEAT
P35	PLUG-TEST, COOL
S4	SWITCH-LIMIT,HI PRESS COMP 1
S7	SWITCH-LIMIT,HI PRESS COMP 2
S11	SWITCH-LOW PRESS,LOW AMB KIT
S42	SWITCH-OVERLOAD
S49	SWITCH-FREEZESTAT, COMP 1
S50	SWITCH-FREEZESTAT, COMP 2
S74	SWITCH-FIRESTAT 1
S75	SWITCH-FIRESTAT 2
S84	SWITCH-LOW PRESS,LOW AMB KIT
TB34	TERMINAL STRIP-TRANSFORMER T1
T1	TRANSFORMER-CONTROL

IF ANY WIRE IN THIS APPLIANCE IS REPLACED, IT MUST BE REPLACED WITH WIRE OF LIKE SIZE,RATING AND INSULATION THICKNESS.

DISCONNECT ALL POWER BEFORE SERVICING

— DENOTES OPTIONAL COMPONENTS

WARNING-ELECTRIC SHOCK HAZARD,CAN CAUSE INJURY OR DEATH. UNIT MUST BE GROUNDED IN ACCORDANCE WITH NATIONAL AND LOCAL CODES

— LINE VOLTAGE FIELD INSTALLED

WIRING DIAGRAM		B/01
COOLING UNITS-PACKAGED		
CHA16-090-1,2-G,J,M,Y		
COOLING SECTION B2		
Supersedes Form No.	New Form No.	
532,993W	533,114W	
©2001		Litho U.S.A.

CHA16-120/150 WIRING DIAGRAM

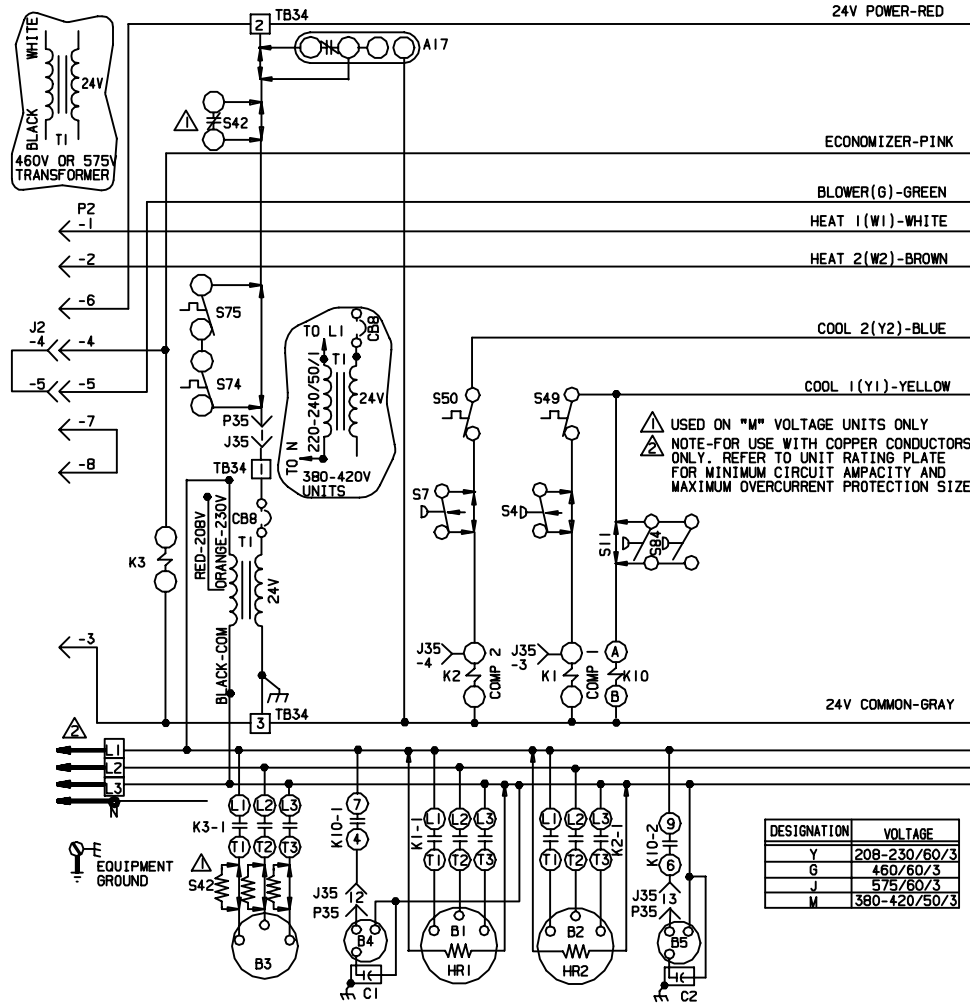

KEY	DESCRIPTION
A17	DETECTOR-SMOKE
B1	COMPRESSOR 1
B2	COMPRESSOR 2
B3	MOTOR-BLOWER
B4	MOTOR-COND FAN 1
B5	MOTOR-COND FAN 2
C1	CAPACITOR-COND FAN 1
C2	CAPACITOR-COND FAN 2
CB8	CIRCUIT BREAKER-TRANSFORMER T1
HR1	HEATER-COMPRESSOR 1
HR2	HEATER-COMPRESSOR 2
J2	JACK-UNIT, HEAT
J35	JACK-TEST, COOL
K1,-1	CONTACTOR-COMPRESSOR 1
K2,-1	CONTACTOR-COMPRESSOR 2
K3,-1	CONTACTOR-BLOWER
K10,-1,2	RELAY-OUTDOOR FAN
P2	PLUG-UNIT, HEAT
P35	PLUG-TEST, COOL
S7	SWITCH-LIMIT HI PRESS COMP 2
S11	SWITCH-LOW PRESS, LOW AMB KIT
S42	SWITCH-OVERLOAD
S49	SWITCH-FREEZESTAT, COMP 1
S50	SWITCH-FREEZESTAT, COMP 2
S74	SWITCH-FREESTAT 1
S75	SWITCH-FREESTAT 2
S91	SWITCH-LOW PRESS, LOW AMB COMP 2
TB34	TERMINAL STRIP-TRANSFORMER T1
T1	TRANSFORMER-CONTROL

IF ANY WIRE IN THIS APPLIANCE IS REPLACED, IT MUST BE REPLACED WITH WIRE OF LIKE SIZE, RATING AND INSULATION THICKNESS.

DISCONNECT ALL POWER BEFORE SERVICING

← DENOTES OPTIONAL COMPONENTS

WARNING-ELECTRIC SHOCK HAZARD, CAN CAUSE INJURY OR DEATH. UNIT MUST BE GROUNDED IN ACCORDANCE WITH NATIONAL AND LOCAL CODES

— LINE VOLTAGE FIELD INSTALLED

WIRING DIAGRAM B/01	
COOLING UNITS-PACKAGED	
CHA16-120-2-G, J, M, Y CHA16-150-1-G, J, M, Y	
COOLING SECTION B2	
Supersedes Form No. 532, 926W	New Form No. 533, 097W

© 2001 Litho U.S.A.

CHA SEQUENCE OF OPERATION

Operation Sequence

Cooling: 1st. Stage

- 1- Line voltage energizes transformer T1. Transformer T1 provides 24VAC power to all unit controls and thermostat.
- 2- Cooling demand energizes Y1 and G in the thermostat. K3 blower relay is energized. Simultaneously, voltage passes through S49 freezeostat, optional low ambient kit S11 or S84 (assuming liquid line pressure is high enough) energizing K1 compressor contactor and K10 condenser fan relay.

- 3- K1-1 closes to energize compressor B1 and K10-1 and K10-2 close to energize condenser fans B4 and B5. Compressor B1 and condenser fans B4 and B5 immediately begin operating. Simultaneously K3-1 contacts close energizing indoor blower B3.

Cooling: 2nd. Stage

- 4- Cooling demand energizes Y2 in the thermostat. Voltage passes through S50 freezeostat and optional S7 high pressure switch to energize K2 compressor contactor. K2-1 contacts close energizing compressor B2.

ECH16-135-50 KW Y VOLTAGE

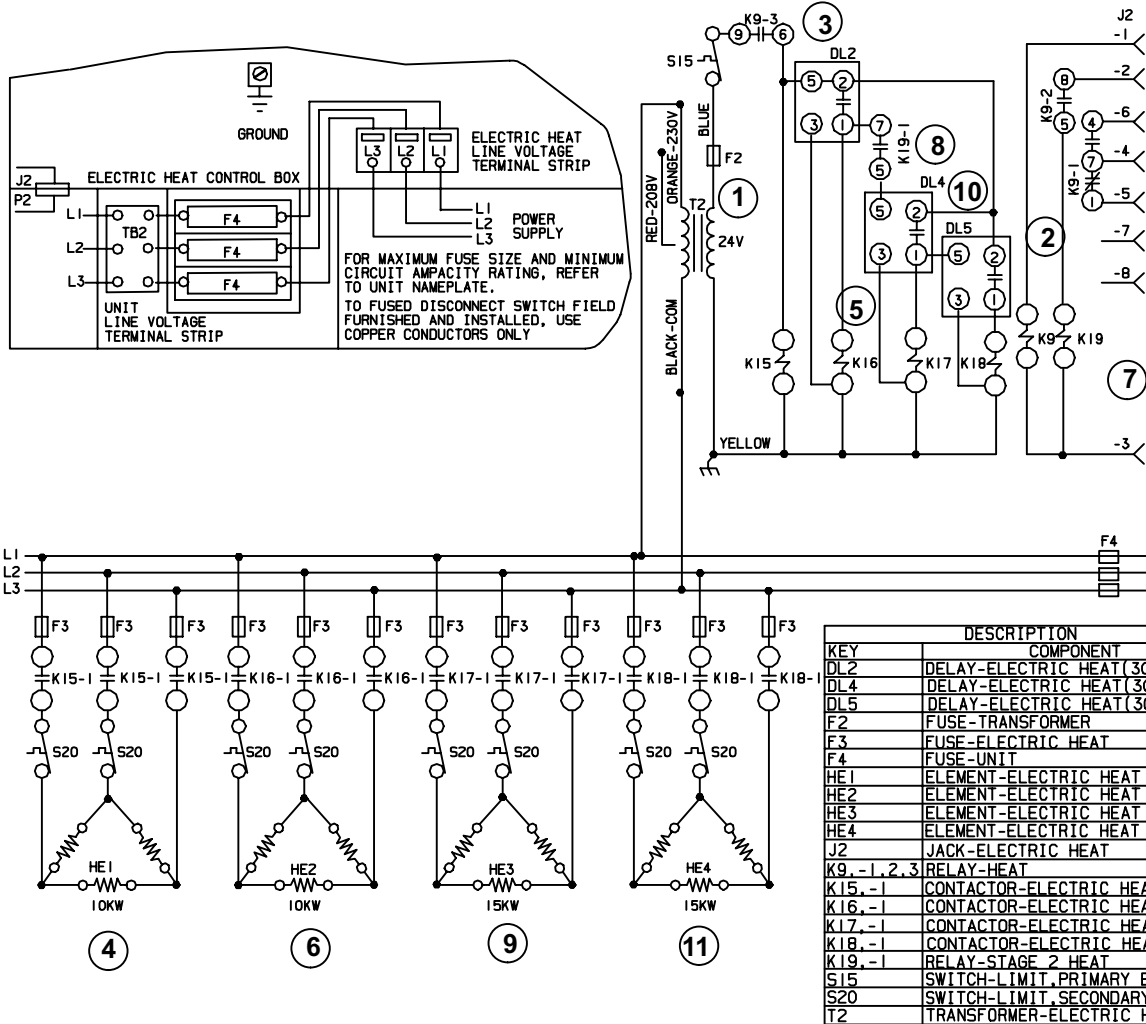

NOTE-For ECH16-15kW follow steps 1 through 4 (minus DL2). For ECH16-30, follow steps 1 through 5. For ECH16-40 follow steps 1 through 8 (minus DL5).

- 1-Control voltage in this heater is supplied by a separate transformer T2 which is powered at all times.
- 2-1st stage heating demand closes W1. W1 energizes relay K9.
- 3-When K9-1 switches, indoor blower contactor K3 is energized. The indoor blower is powered (and optional economizer opens to minimum position when K3-2 contacts close). When K9-2 closes, second stage heat is enabled. When K9-3 closes, control voltage passes through primary limit S15 to energize contactor K15 and time delay DL2.

- 4-When K15-1 closes, heating elements HE1 are energized. All elements are arranged in a "Delta" configuration for 208/230V operation.
- 5-DL2 closes 30 seconds later to energize contactor K16.
- 6-When K16-1 closes heating elements HE2 are energized.
- 7-Additional heating demand W2 passes through K9-2 to energize relay K19.
- 8-When K19-1 switches, time delay DL4 is energized. DL4 closes 30 seconds later to energize contactor K17 and time delay DL5.
- 9-When K17-1 closes heating elements HE3 are energized,
- 10-DL5 closes after 30 seconds to energize contactor K18.
- 11-When K18-1 closes, heating elements HE4 are energized.

WIRING DIAGRAM		4/99
HEATING-ELECTRIC		
ECH16-135-50-1, 2, 3-Y		
HEATING SECTION A4		
Supersedes Form No. 528,316W	New Form No. 529,231W	
©1998 Lennox Industries Inc.		Litho U.S.A.

ECH16-135-50 kW G & J VOLTAGE

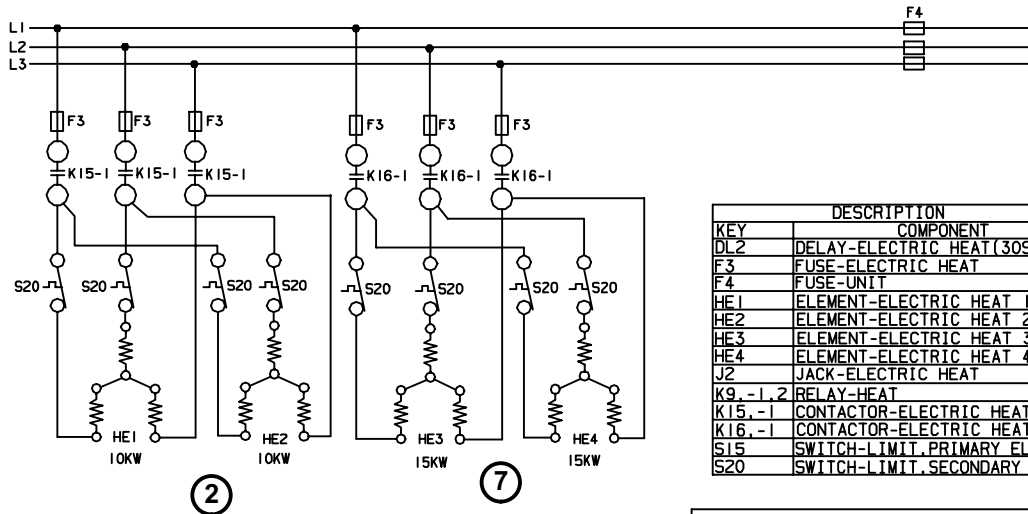
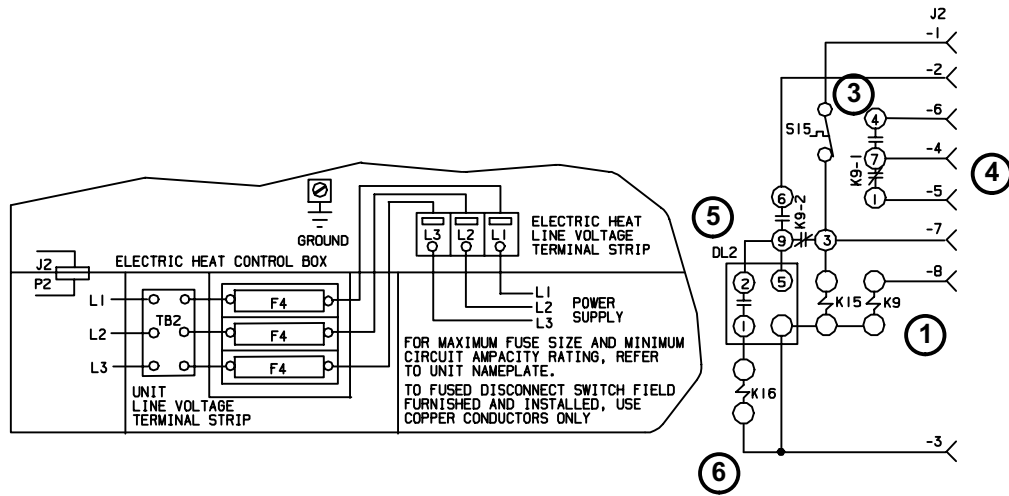

KEY	DESCRIPTION
DL2	DELAY-ELECTRIC HEAT (30SEC)
F3	FUSE-ELECTRIC HEAT
F4	FUSE-UNIT
HE1	ELEMENT-ELECTRIC HEAT 1
HE2	ELEMENT-ELECTRIC HEAT 2
HE3	ELEMENT-ELECTRIC HEAT 3
HE4	ELEMENT-ELECTRIC HEAT 4
J2	JACK-ELECTRIC HEAT
K9 - 1, 2	RELAY-HEAT
K15, - 1	CONTACTOR-ELECTRIC HEAT 1
K16, - 1	CONTACTOR-ELECTRIC HEAT 2
S15	SWITCH-LIMIT PRIMARY ELECT HT
S20	SWITCH-LIMIT SECONDARY ELECT HT

WIRING DIAGRAM		4/99
HEATING-ELECTRIC		
ECH16-135-50-1, 2, 3-G, J		
HEATING SECTION AB		
Supersedes Form No. 528, 320W		New Form No. 529, 235W
© 1999 Lennox Industries Inc.		Litho U.S.A.

NOTE-For ECH16-15kW, 20kW & 30kW, follow steps 1 through 4 (minus DL2).

Operation Sequence:

- 1- 1st stage heating demand closes W1. W1 passes through primary limits S15 to energize contactor K15 and relay K9. K15-1 contacts close and K9-1 and K9-2 both switch.
- 2- When K15-1 closes, heating elements HE1 and HE2 are both energized. The elements are arranged in a "Wye" configuration for 460V or 575V operation.
- 3- When K9-1 switches, indoor blower contactor K3 is energized. When K9-2 switches, time delay DL2 is enabled (circuit is closed to W2).
- 4- When K3 is energized, the indoor blower is powered (and optional economizer opens to minimum position when K3-2 contacts close).
- 5- Additional heating demand W2 passes through K9-2 to energize time delay DL2.
- 6- DL2 closes after 30 seconds. Contactor K16 is energized.
- 7- When K16-1 closes, heating elements HE3 and HE4 are energized.

ELECTROMECHANICAL THERMOSTAT WITH ECONOMIZER

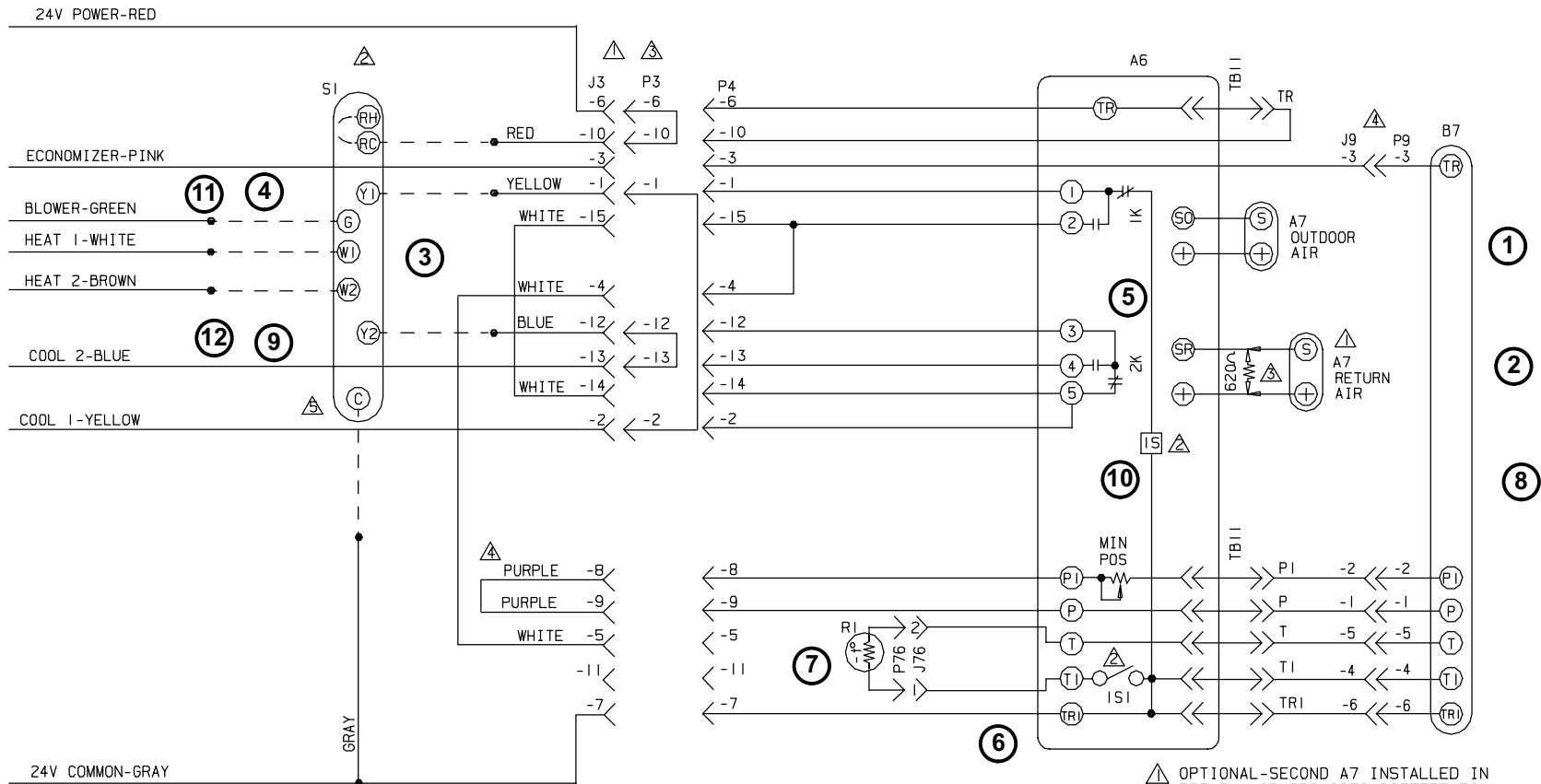

DESCRIPTION	
KEY	COMPONENT
J3	JACK-UNIT, ECONOMIZER
P3	PLUG-LESS ECONOMIZER
S1	THERMOSTAT-ROOM

--- LOW VOLTAGE FIELD WIRING
 _____ FACTORY WIRING

- ⚠ DO NOT CONNECT GRAY COMMON WIRE UNLESS THE THERMOSTAT HAS TERMINAL "C" COMMON. MOST ELECTROMECHANICAL THERMOSTATS DO NOT HAVE THE "C" TERMINAL
- ⚠ PURPLE JUMPER WIRE IS MADE LONG TO EXTEND INTO JUNCTION BOX
- ⚠ REMOVE P3 WHEN ECONOMIZER IS USED
- ⚠ THERMOSTAT SUPPLIED BY USER
- ⚠ J3 MAXIMUM LOAD 20VA 24VAC CLASS II

- ⚠ OPTIONAL-SECOND A7 INSTALLED IN RETURN AIR PROVIDES DIFFERENTIAL ENTHALPY CONTROL
- ⚠ WHEN IS RECEIVES POWER, ISI CLOSSES.
- ⚠ FACTORY INSTALLED 620 OHM, 1 WATT, 5% RESISTOR. REMOVE WHEN SECOND A7 SENSOR IS INSTALLED TO PROVIDE DIFFERENTIAL ENTHALPY CONTROL
- ⚠ J9 AND P9 MAY OR MAY NOT BE USED

WIRING DIAGRAM		11/99
ACCESSORIES		
ELECTROMECHANICAL THERMOSTAT FOR 16 & 20 SERIES VALUE LINE (2 HEAT, 2 COOL)		
THERMOSTAT-SECTION C1		
Supersedes Form No. 532, 928W	New Form No. 533, 392W	

DESCRIPTION	
KEY	COMPONENT
A6	CONTROL - ENTHALPY W7459A
A7	SENSOR-ENTHALPY
B7	MOTOR-DAMPER
J9	JACK-ECONOMIZER, MOTOR
J76	JACK-SENSOR ECONOMIZER
P4	PLUG-ECONOMIZER
P9	PLUG-ECONOMIZER, MOTOR
P76	PLUG-SENSOR ECONOMIZER
R1	SENSOR-SUPPLY AIR
TB11	TERMINAL STRIP

WIRING DIAGRAM		11/99
ACCESSORIES		
REMD-16-M EMDH-16-M MODULATING ECONOMIZER FOR VALUE LINE UNITS		
ECONOMIZER-SECTION D5		
Supersedes Form No.	New Form No. 533, 305W	

ELECTROMECHANICAL THERMOSTAT WITH ECONOMIZER

Operation Sequence:

- 1- Economizer outdoor air dampers drive full closed anytime blower B3 is not operating (switched by K3-2 in the unit).
- 2- Damper motor terminal TR is powered by unit contactor K3 when there is a blower demand or a heating demand. When 24VAC is applied between terminals TR and TR1, the damper motor is energized and the outdoor air dampers open to minimum position.
- 3- Blower B3 is energized (indirectly) by thermostat terminal G. On a cooling demand, thermostat terminal G energizes contactor K3 which in turn energizes the blower (refer to operation sequence on previous page for exact sequence). When K3 energizes, K3-1 closes to energize the blower and K3-2 closes to energize the economizer (see step 2) and open the outdoor air dampers to minimum position.

Enthalpy Low, 1st Stage Cool:

- 4- Initial cooling demand Y1 is sent to enthalpy control A6 and terminal 1.
- 5- Enthalpy control A6 has determined that outside air can be used for cooling and has switched internal relays 1K and 2K.
- 6- Cooling demand is routed through enthalpy control to energize internal relay 1S. Internal contacts 1S1 close to complete a circuit through damper motor terminals T and T1.
- 7- When 24 volts is applied across terminals T and T1 of damper motor, the damper motor energizes and outdoor air dampers open. Supply air sensor R1 varies the voltage across T and T1 and the outdoor air dampers open and adjust accordingly. 1st stage cooling is provided by outdoor air.

Enthalpy Low, 2nd Stage Cool:

- 8- Economizer outdoor air dampers remain open.
- 9- Additional cooling demand is routed from thermostat Y2 through enthalpy control terminals 3 and 5 to energize the 1st stage compressors. The 1st stage compressors provide all additional cooling.

Enthalpy High, 1st Stage Cool:

- 10-Enthalpy control internal relays 1K and 2K switch. Internal relay 1S is de-energized and 1S1 opens. Outdoor air dampers close to minimum position.
- 11-Cooling demand is sent from thermostat terminal Y1 through enthalpy control terminals 1 and 2 and through enthalpy control terminal 5 to energize the 1st stage compressors.

Enthalpy High, 2nd Stage Cool:

- 12-Additional cooling demand is sent from thermostat terminal Y2 through enthalpy control terminals 3 and 4 to energize the 2nd stage compressor.

SERVICE NOTES