

CB21 SERIES UNITS INCLUDING CB21, CBH21 and B21 / CH21 SERIES BLOWER COILS, ECB21 ELECTRIC HEAT and EFFICIENCY PLUS COMFORT MANAGEMENT SYSTEM (CCB1)

The CB21 is a high efficiency residential split system blower/coil featuring an electronically commutated direct drive motor (ECM) controlled by an electronic blower drive control (BDC).

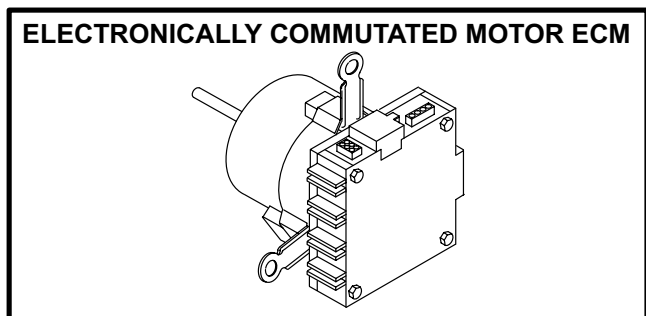

CB21 series units are designed to be matched with 21 series two-speed outdoor units. Several models are available in sizes ranging from 3 through 5 tons. All units are designed to use check type thermal expansion valve (TXV) as the primary expansion device.

Some CB21, CBH21 or B21 units may have the optional Efficiency Plus Comfort Management Control (CCB1) installed. The control is installed indoors adjacent to the indoor thermostat. Its purpose is to vary indoor blower speed in response to indoor humidity demand. When a 21 series outdoor unit is used, compressor speed can also be controlled by the CCB1 in response to indoor humidity demand.

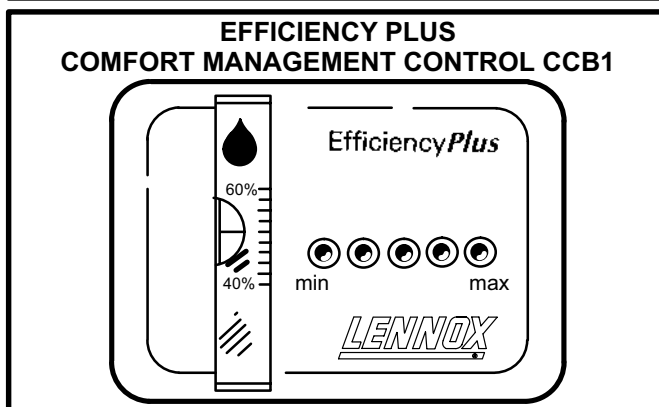
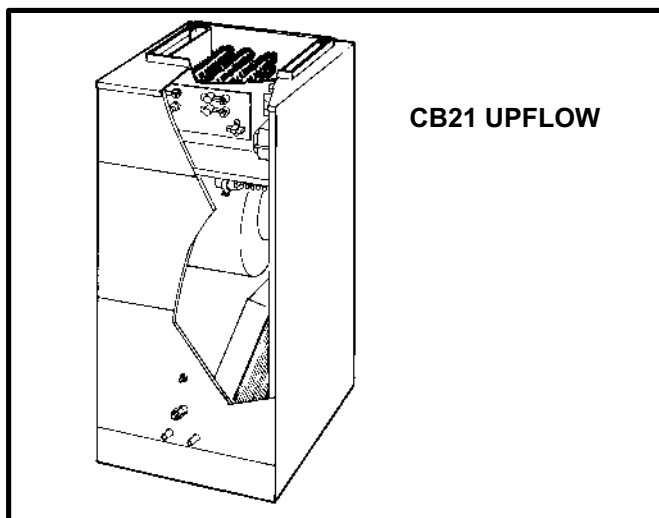

All specifications in this manual are subject to change.

SPECIFICATIONS

Model No.	CB21-41	CBH21-41	CB21-51	CBH21-51	CB21-65	CBH21-65	
Blower Section	----	----	----	B21-51/65	----	B21-51/65	
Indoor Coil Section	----	----	----	CH21-51	----	CH19-65	
Indoor Coil	Net face area (sq.ft.)	5.27	5.27	7.0	7.22	7.0	7.22
	Tube diameter (in.) & no. of rows	3/8 - 3	3/8 - 3	3/8 - 3	3/8 - 3	3/8 - 3	3/8 - 3
	Fins per inch	13	13	14	14	14	14
	Vapor line connection (in.) - flare	3/4	3/4	3/4	3/4	1-1/8 sweat	1-1/8 sweat
	Liquid line connection (in.) - flare	3/8	3/8	3/8	3/8	3/8	3/8
Condensate drain (mpt) in.	(2) 3/4	(2) 3/4	(2) 3/4	(2) 3/4	(2) 3/4	(2) 3/4	
Nominal cooling capacity (tons)	3		4		5		
Refrigerant	R-22		R-22		R-22		
Blower wheel nominal diameter x width (in.)	10 x 9		12 x 9		12 x 9		
Blower motor hp	1/2		1		1		
Electrical characteristics	208/230 v-60 hz-1 ph						

I-APPLICATION

CB21 series includes several different models. CB21 models are field convertible upflow or downflow units. CBH21 models are horizontal flow units only. The CBH21-51 is a two-piece cabinet composed of a B21-51/65 blower section connected to a CH21-51 indoor coil section; the CBH21-65 is also a two-piece cabinet composed of a B21-51/65 blower section connected to a CH19-65 indoor coil section.

The B21-51/65 cabinet includes blower and electrical controls. The CH21-51 cabinet includes a coil equipped for TXV (thermal expansion valve). The CH19-65 coil includes a RFCIII (refrigerant flow control) which must be converted to TXV for use with the 21 series system.

All major components (indoor blower / coils) must be matched according to Lennox recommendations for the compressor to be covered under warranty. Refer to the Engineering Handbook for approved system matchups. A misapplied system will cause erratic operation and can result in early compressor failure.

A-Unit Matchups

All CB21 series units must use thermal expansion valves as the primary expansion device. RFCIII is not an approved matchup. RFCIII to expansion valve changeover is covered in detail in this manual.

II-INDOOR CONTROLS

A-Indoor Thermostat S1

TABLE 1

THERMOSTAT / CPS21 TERMINAL STRIP DESIGNATION		
Terminal Designation	Cooling Mode Function	Heating Mode Function
R	24VAC Power	24VAC Power
G	Blower	---
X	Common	Common
Y1	Low Speed Compressor	Low/High Compressor
Y2	High Speed Compressor	---
W1	---	1st Stage Strip Heat
W2	---	2nd Stage Strip Heat (Em. Heat)
O	Reversing Valve	---
DS	Dehumidification Switch (see table 2)	---
W3*	---	3rd Stage Strip Heat (Em. Heat)

*Indoor thermostat may not be equipped with W3 terminal

CB21 and matching HP21 series units use a 2 heat/2 cool heat pump thermostat with optional emergency heat capability. Thermostat terminal designations are shown in table 1.

B-Comfort Control Board A20 (CCB1)

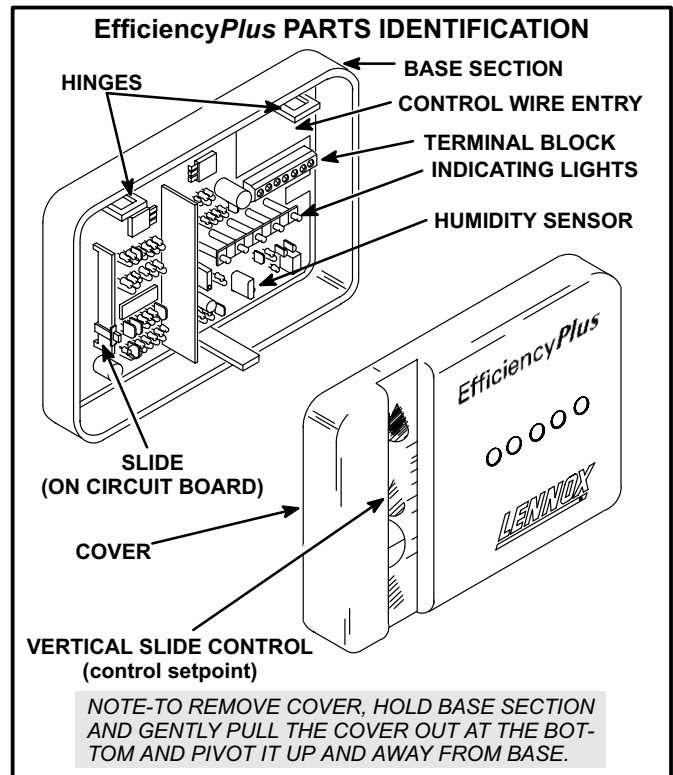

FIGURE 1

Optional Comfort Control Board (CCB1) A20 may be installed adjacent to the indoor thermostat (figure 1). The control monitors indoor humidity conditions and creates a dehumidification demand in response to indoor humidity just as the thermostat creates a cooling demand in response to indoor temperature. The CCB1 works in combination with the indoor thermostat to adjust compressor speed and indoor blower speed. Although the control provides a humidity cooling demand, only the thermostat can directly control compressor operation. The CCB cannot call for a compressor cycle by itself.

Principles of Cooling with Drier Air

The humidity comfort range for humans is between 40% and 60% relative humidity (RH). A vertical slide on the control allows the humidity setpoint to be adjusted within that comfort range. 50% RH is the recommended initial setpoint until personal comfort level is established. The personal comfort level will vary with

humidity as with temperature. For example, if air at 75°F and 50% RH is changed to 60% RH, the air will “feel” much warmer. Likewise, if the air is reduced to 40% RH, it will “feel” much cooler.

Even when inactive, the body evaporates a large amount of moisture away from the skin. This evaporation produces a cooling effect (during wintertime this phenomenon is called “wind-chill”). Dry air is capable of absorbing more moisture away from the skin thereby increasing the cooling effect.

When the CCB1 senses that the indoor humidity level is above the control setpoint, the control places the CB21 and outdoor unit in a dehumidification mode (in order to take advantage of the dry air cooling effect).

To produce drier air, the CB21 will slow down the speed of the air crossing the indoor coil. Because the air is moving much slower than normal, the indoor coil is allowed more time to remove moisture from the air (air passing the coil is allowed more time to reach the dew point e.g. more latent heat is removed from the air). At the same time the two-speed outdoor unit will switch to high-speed to produce a colder indoor coil. The colder indoor coil and slower moving air combine to produce drier supply air.

NOTE-The indoor blower speed is reduced in order to slow the airspeed across the indoor coil. The supply air exiting the unit may not feel as forceful. This is normal. Remember that when the unit is in dehumidification mode, the comfort level is increased because the unit is producing cooler, drier air.

The exact sequence of operation to produce cooler, drier air is described in the following section.

Operation

The CCB1 operates only during cooling mode. During normal cooling operation, when there is no indoor humidity demand, the unit operates as a straight two-speed cooling system. 1st stage thermostat demand energizes the compressor and indoor blower on low speed. Increased cooling demand energizes the compressor and indoor blower on high speed.

The control is equipped with a row of orange LED lights on its face which indicate the amount of relative humidity demand present. When one or more LEDs are lit, the control signals the CB21 to begin dehumidification mode. Table 2 shows system response to thermostat and CCB1 demand.

Calibration Precautions

Extreme care should be taken to avoid exposing the CCB1 to fumes from household chemicals. The humidity sensing element in the CCB1 is a precise component which can be damaged or thrown out of calibration by household chemicals and cleaning agents. Make sure all household chemicals are stored in a different room in the building. Also, use only mild diluted soapy water when cleaning the CCB1 cover or the area surrounding the CCB1. The sensing element cannot be field calibrated. The CCB1 contains no field repairable parts and must be replaced when damaged in this manner.

Agents which can damage the CCB1 include alcohol, benzene, chlorine and chlorine based solutions, acetone (nail polish remover), bug sprays and other household cleaners.

Calibration can also be adversely affected by the placement of the CCB1 with respect to the indoor thermostat, exterior doors and windows and supply air registers. Most thermostats have anticipation resistors which give off heat. If the CCB1 is installed directly above the indoor thermostat the humidity sensor calibration will be thrown off. If the CCB1 is installed directly above the indoor thermostat, it should be relocated to the side of the thermostat. Refer to CCB1 installation instructions.

Other Conditions Which Adversely Affect CCB1 Performance

Blower speed selection can adversely affect CCB1 performance. High speed blower taps should be selected to provide maximum sensible cooling while low speed taps should be selected to provide maximum humidity removal. Refer to CB21 and CCB1 application literature.

It is recommended that the indoor blower be left in AUTO mode at all times. During dehumidification mode, the indoor coil and drain pan may become saturated with moisture. If the indoor blower is left in ON mode, much of that moisture can be evaporated into the living space between thermostat demands. This can create a constant demand for humidity removal and may cause extended compressor run times.

The CCB1 may become indefinitely latched in the dehumidification mode when power to the unit is turned off. This condition can be caused by turning off power while dehumidification demand is present then turning on power when dehumidification demand is satisfied. If the CCB1 becomes stuck in this manner, it can be reset by removing thermostat demand then moving the CCB1 slide switch all the way down and back up to its setpoint.

How to unlatch CCB1

- 1- Force a cooling demand by setting thermostat to COOL mode and by moving thermostat lever to lowest position.
- 2- Move CCB1 slide control down to 40% relative humidity. CCB1 lights should come on.
- 3- Now, move CCB1 slide control back up to 60% relative humidity. The lights should go off.
- 4- Remove thermostat demand by moving thermostat lever to cycle unit off.

**TABLE 2
CCB1 TYPICAL OPERATING SEQUENCE**

OPERATING SEQUENCE		SYSTEM DEMAND		SYSTEM RESPONSE		
System Condition	Step	Thermostat Demand	*Relative Humidity (EfficiencyPlus Lights)	Compressor Speed	Blower CFM (Cooling)	Comments
Normal operation	1	Y1	Acceptable (None)	Low	Low	Compressor demand and indoor blower speed follow thermostat demand.
	2	Y2	Acceptable (None)	High	High	
Call for humidity removal during 1st stage thermostat demand.	1	Y1	Acceptable (None)	Low	Low	Dehumidification mode begins with next thermostat demand after initial thermostat demand is satisfied.
	2	Y1	Change to Slightly over setpoint (1)	Low	Low	
	3	Demand Satisfied	Slightly over setpoint (1)	Off	Off	
	4	Y1	Slightly over setpoint (1)	High	Low	
Significant increase in humidity during thermostat demand.	1	Y1	Acceptable (None)	Low	Low	If humidity increases significantly over setpoint or if slide switch is moved significantly, unit will immediately go into dehumidification mode (in presence of thermostat demand).
	2	Y1	Change to Significantly over setpoint (2 or more)	High	Low	
Humidity demand satisfied during thermostat demand.	1	Y1	Over Setpoint	High	Low	When humidity demand is satisfied, blower immediately shifts to high speed in order to hasten the end of the cycle. Unit can only shift out of dehumidification mode at beginning of next cycle.
	2	Y1	Change to Acceptable (None)	High	High	
	3	None	Acceptable (None)	Off	Off	
	4	Y1	Acceptable (None)	Low	Low	
Call for humidity removal during 2nd stage thermostat demand.	1	Y2	Acceptable (None)	High	High	Blower immediately changes speed in response to thermostat demand.
	2	Y2	Change to Slightly over setpoint (1)	High	Low	
	3	Y2	Acceptable (None)	High	High	
*Call for 1st stage cooling after call for humidity removal.	1	None	Slightly over setpoint (1)	Off	Off	Dehumidification mode (high speed compressor) begins with next thermostat demand after initial demand is satisfied.
	2	Y1	Slightly over setpoint (1)	Low	Low	
Call for 2nd stage cooling after call for humidity removal.	1	None	Slightly over setpoint (1)	Off	Off	Low speed blower (dehumidification speed) begins immediately with thermostat demand.
	2	Y2	Slightly over setpoint (1)	High	Low	
Call for cooling after significant increase in humidity.	1	None	Significantly over setpoint (2 or more)	Off	Off	If humidity increases significantly over setpoint or if slide switch is moved, unit immediately goes into dehumidification mode (in presence of thermostat demand).
	2	Y1 or Y2	Significantly over setpoint (2 or more)	High	Low	
Humidity demand satisfied between thermostat demands (unit off cycle).	1	None	Over setpoint (1 or more)	Off	Off	While unit is not operating (no thermostat demand) slide switch is moved down and back up. Blower and compressor operate at high speed until next thermostat demand.
	2	Y1 or Y2	Change to Acceptable (None)	High	High	

Note-When changing unit mode of operation from cooling to heating, indicating lights that are on will stay on until the first thermostat heating demand.

**IMPORTANT-If power to unit is turned on with CCB1 calling for humidity removal, outdoor unit may be locked into high speed indefinitely. To reset, move humidity slide switch all the way down then back up to desired setpoint (with unit running).*

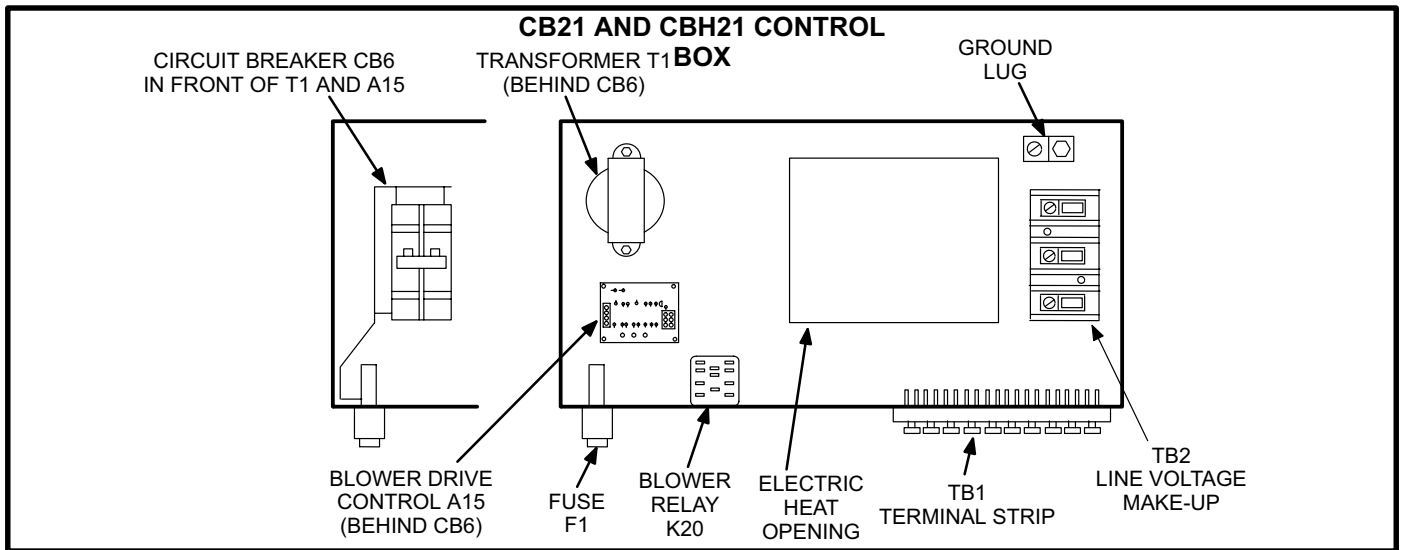

FIGURE 2

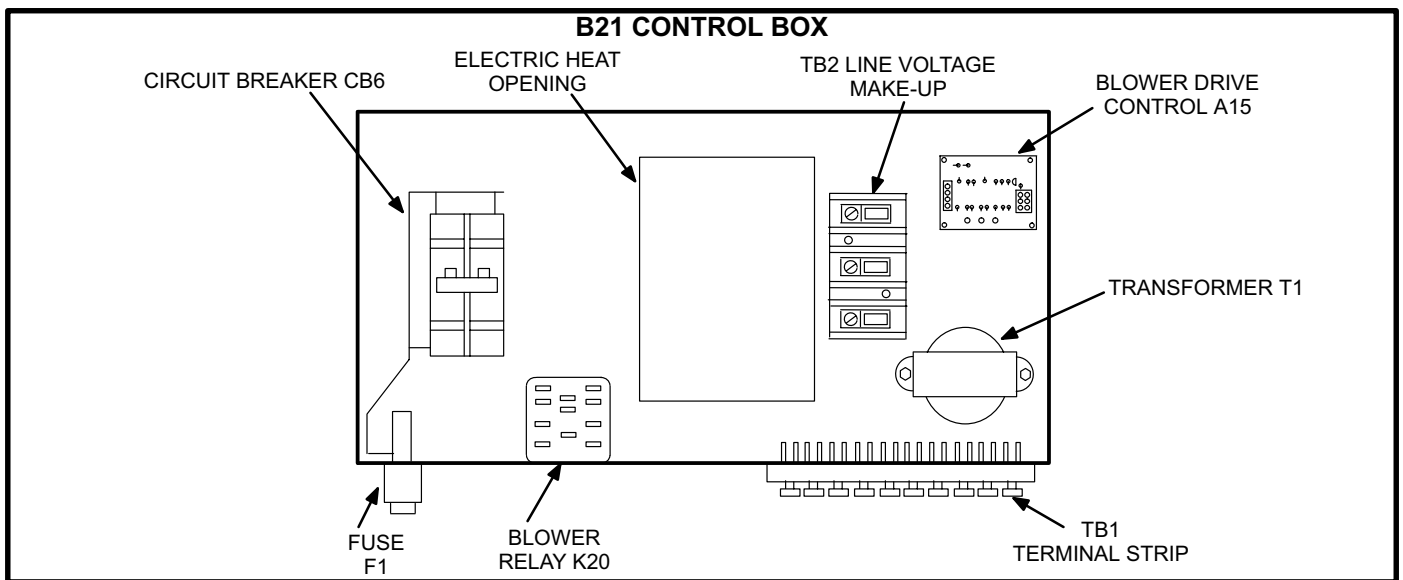

FIGURE 3

III-UNIT COMPONENTS

B21, CB21 and CBH21 control box is shown in figures 2 and 3. Optional electric heat fits through an opening located in the center of the control box. Filler plates cover this opening when no electric heat is used. Electric heat control arrangement is detailed in the electric heat section of this manual.

A-Transformer T1

All CB21 series units use a single line voltage to 24VAC transformer mounted in the control box. The transformer supplies power to the control circuits in the indoor and outdoor unit as well as the thermostat. Transformers are rated at 70VA and use two primary voltage taps as shown in figure 4.

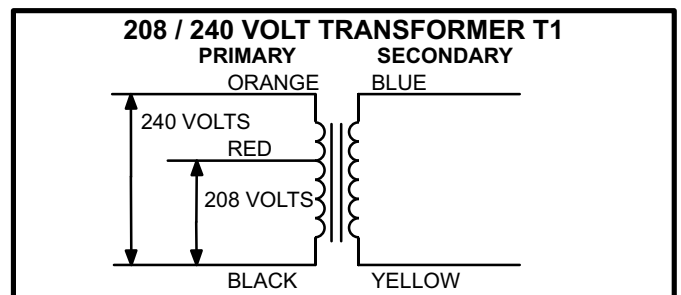

FIGURE 4

B-Fuse F1

All units are equipped with secondary voltage overcurrent fuse located in the unit control box. The fuse is connected in series with the blue 24 volt transformer output wire. It is used to protect all 24V controls which are powered by transformer T1. The fuse is rated 3.2A at 300V.

C-Terminal Strip TB1

All CB21, CBH21 and B21 units are equipped with a low voltage terminal strip located in the control box. The strip is used for making up all indoor thermostat and outdoor unit low voltage wiring connections (see figures 2 and 3).

CB21 series units require jumper wires to be field installed on the unit terminal strip. Jumper connections used differ depending on the application as shown in table 3.

TABLE

CB21 UNITS FIELD INSTALLED JUMPERS REQUIRED FOR TERMINAL STRIP TB1		
Humidity Control	Outdoor Unit	Jumpers Required
With CCB1 Humidity Control	Single-Speed Heat Pump	Y1 to Y2
	Two-Speed Heat Pump	none
	Single-Speed Condensing Unit	Y1 to Y2 and O to R
	Two-Speed Condensing Unit	O to R
Without CCB1 Humidity Control	Single-Speed Heat Pump	DS to Y1
	Two-Speed Heat Pump	DS to Y2
	Single-Speed Condensing Unit	DS to Y1 and O to R
	Two-Speed Condensing Unit	DS to Y2 and O to R

D-Circuit Breaker CB6

CB21 units are equipped with a line voltage circuit breaker (CB6) protecting the blower motor (B3) and its control circuits (T1 and A15). The circuit breaker is a two-pole, 15 amp 120/240vac manual reset switch located in the control box. The switch fits through a knockout in the cabinet and may be accessed without removing the access panel.

E-Blower Relay K20

All units use a single SPDT relay to energize the blower motor in response to heating demand. The relay coil is energized when the 1st stage electric heat relay closes. When K20 is energized, its N.O. contacts close to energize jackplug JP45 pin 3 (located on blower drive control A15). When JP45 is energized, the blower drive control immediately energizes the blower on heating speed.

Optional electric heating elements are sequenced so that blower relay K20 operates on a first on/last off basis.

F-Blower Drive Control A15 (BDC)

Blower drive control A15, located in the unit control box, provides an interface between the analog 24VAC indoor thermostat signal and the direct current digital signal to the blower motor. The control is responsible for energizing the blower motor in response to thermostat demand and for converting thermostat demand from 24VAC to 24VAC halfwave rectified (half-rectified, see figure 5). The ECM motor controller (inside the blower motor) is responsible for selecting the blower speed.

NOTE-24VAC half-rectified, when measured with a meter, may appear as a lower or higher voltage depending on the make of the meter. Rather than attempting to measure the output voltage of A15, follow the diagnostics outlined in this manual when troubleshooting the unit.

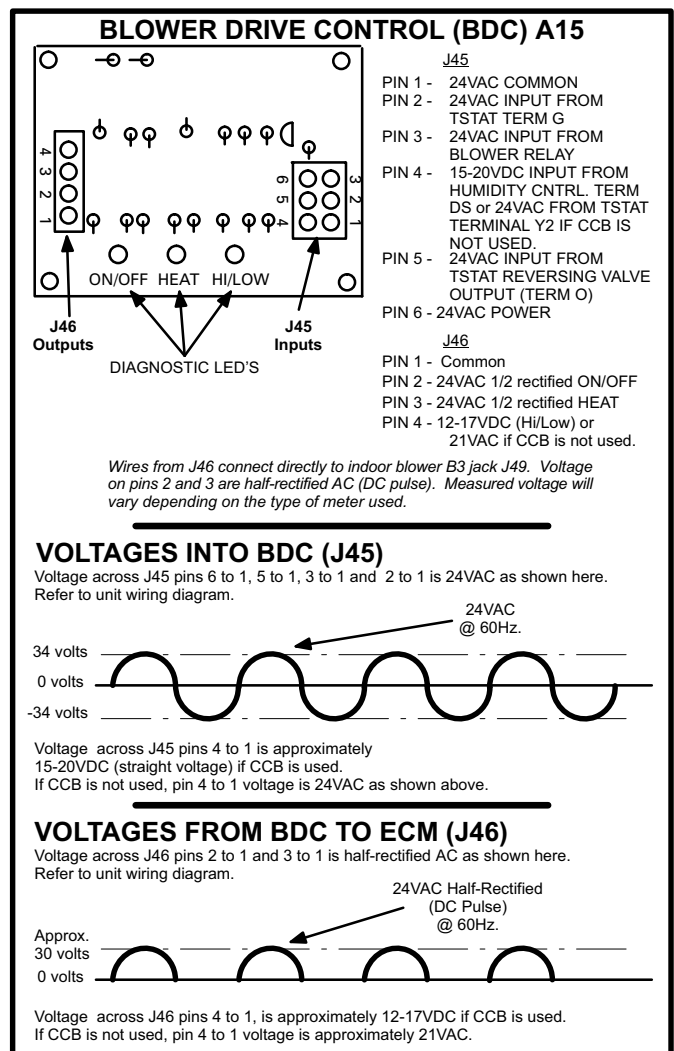

FIGURE 5

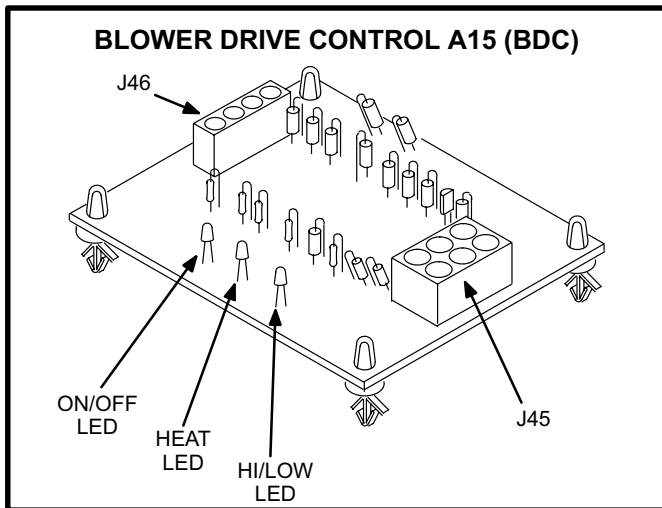

FIGURE 6

Diagnostic LED Lights: Cooling Mode

Three diagnostic LED lights are provided on the control for troubleshooting. The three lights (figure 6) are “ON/OFF,” “HI/LOW” and “HEAT.” In cooling mode, the ON/OFF LED indicates the blower is operating on low speed. It is lit when 24VAC thermostat demand is supplied to the control (jackplug JP45 pin 2). The ON/OFF LED and HI/LOW LED both light to indicate the blower is operating on high speed (15-20VDC from CCB1 terminal DS or 24VAC from Y2 if CCB1 is not used). During dehumidification mode, the CCB1 turns off the DS output and the blower operates on low speed.

Diagnostic LED Lights: Heating Mode

The heat light is energized when 24VAC is supplied to the unit, however, when a cooling demand is present, the light is not energized.

During heating mode, the HEAT light is energized at all times (with or without thermostat demand). The HEAT light is tied electrically to J45 pin 5. Pin 5 receives 24VAC power from the indoor thermostat reversing valve output. When the reversing valve output is off (indicating that the unit is in heating mode), the BDC HEAT light is on.

The ON/OFF and HEAT lights are both energized when the blower is operating on heating speed. During heating operation, the blower operates on HEATING speed regardless of compressor speed or electric heat operation. 2nd stage thermostat demand energizes electric heat but does not change blower speed (or BDC lights). If outdoor temperature drops enough to close the speed control thermostat in the outdoor unit, the compressor goes to high speed but the indoor blower speed does not change (nor do the BDC lights).

The ON/OFF LED may be delayed by the action of thermal heat relays in the ECB21. For example, when the unit is in EM HEAT mode, the ON/OFF light energizes after the thermal heat relay closes and de-energizes after the thermal heat relay opens.

If the unit is switched from a heating demand to a 2nd stage cooling demand, all three lights may be energized for a short time. During this period, the blower operates on heating speed. When the thermal heat relay cools and opens, the HEAT light de-energizes and the blower switches to high speed.

G-Blower / Motor B3 (ECM)

CB21 series units use a single-phase variable-speed ECM (electronically commutated motor, see figure 7). A solid-state controller is permanently attached to the motor.

TABLE 4

ECM BLOWER MOTOR - CCW ROTATION			
Unit	Volts	Phase	HP
CB21/CBH21-41	208/230	1	1/2
CB21/CBH21-51	208/230	1	1
CB21/CBH21-65	208/230	1	1

CB21 series blower motor ratings are shown in table 4. All CB21 blower motors are single phase. An external run capacitor is not used. The motor uses permanently lubricated ball type bearings.

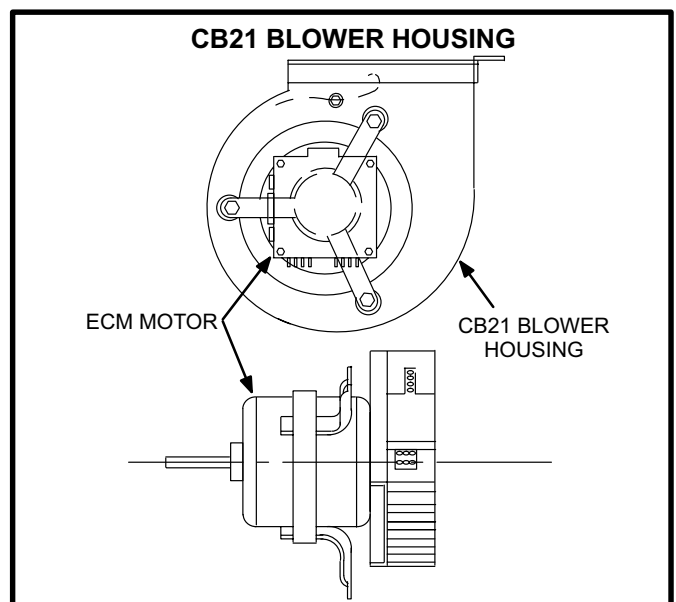

FIGURE 7

What is an ECM?

An electronically commutated motor (ECM) is a three-phase d.c. brushless motor with a permanent-magnet type rotor (figure 8). Because this motor has a permanent magnet rotor it does not need brushes like conventional D.C. motors. ECM internal components are shown in figure 9. The stator windings are split into three poles which are electrically connected to the controller. This arrangement allows the motor windings to be turned on and off in sequence by the controller.

The controller is primarily an a.c. to d.c. converter. Converted d.c. power is used to drive the motor. The ECM controller also contains a microprocessor which monitors varying conditions inside the motor (such as motor workload). For example, the controller uses sensing devices to know what position the rotor is in at any given time. By sensing the position of the rotor and then switching the motor windings on and off in sequence, the rotor shaft turns the blower.

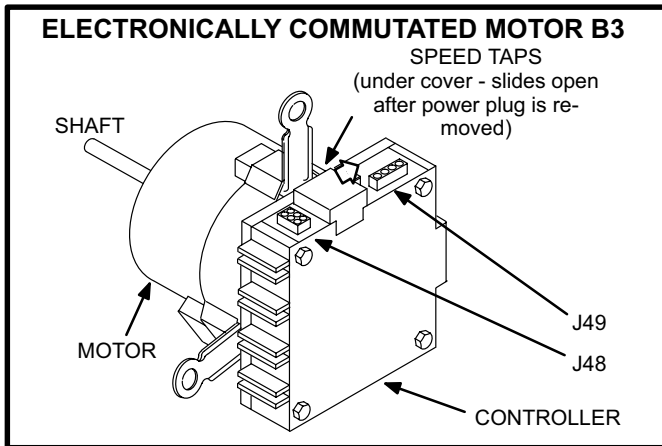

FIGURE 8

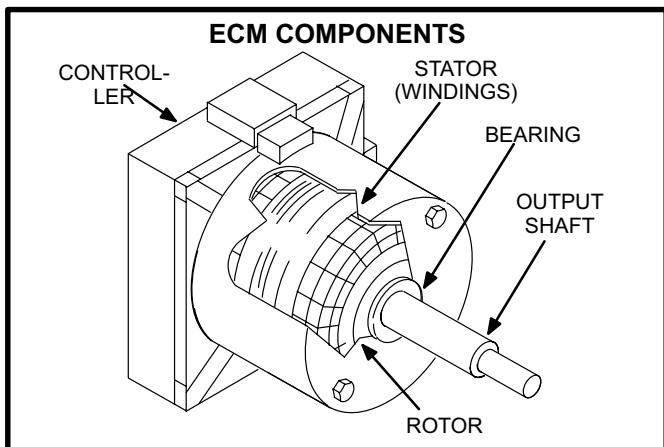

FIGURE 9

Internal Operation

Each time the controller switches a stator winding (figure 9) on and off, it is called a "pulse." The length of time each pulse stays on is called the "pulse width." By varying the pulse width (figure 10), the controller varies the motor speed (called "pulse-width modulation"). This allows for precise control of motor speed and allows the motor to compensate for varying load conditions as sensed by the controller. In this case, the controller monitors the static workload on the motor and varies motor rpm in order to maintain constant airflow (cfm).

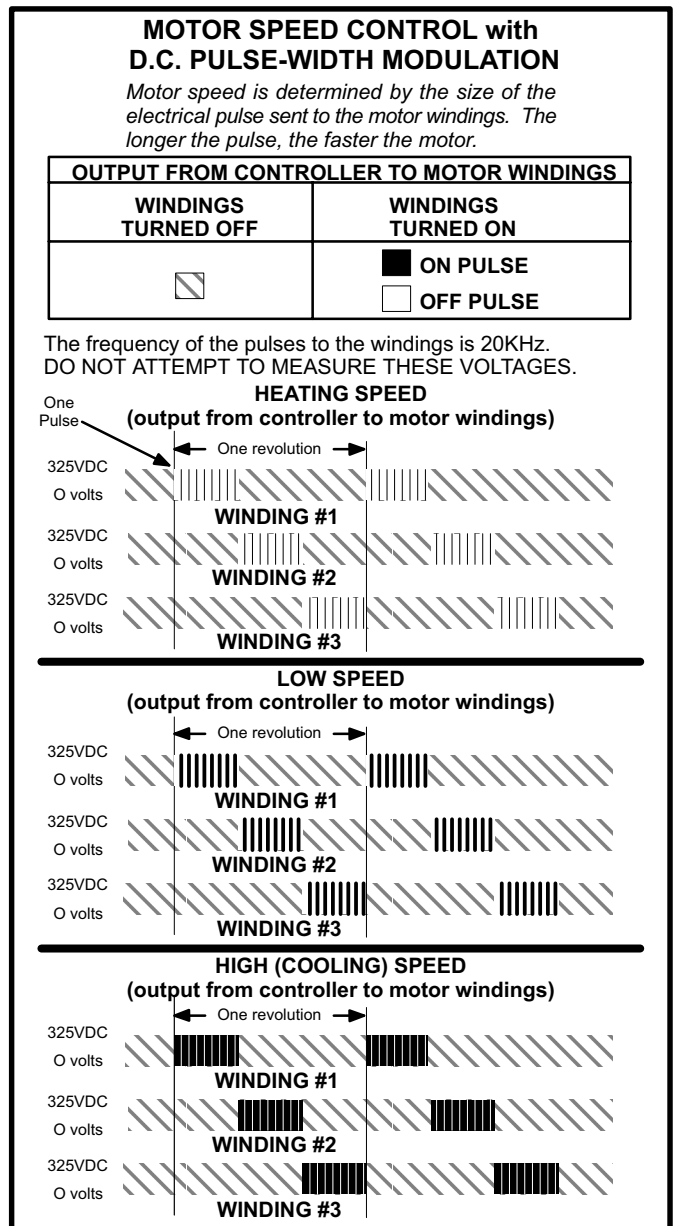
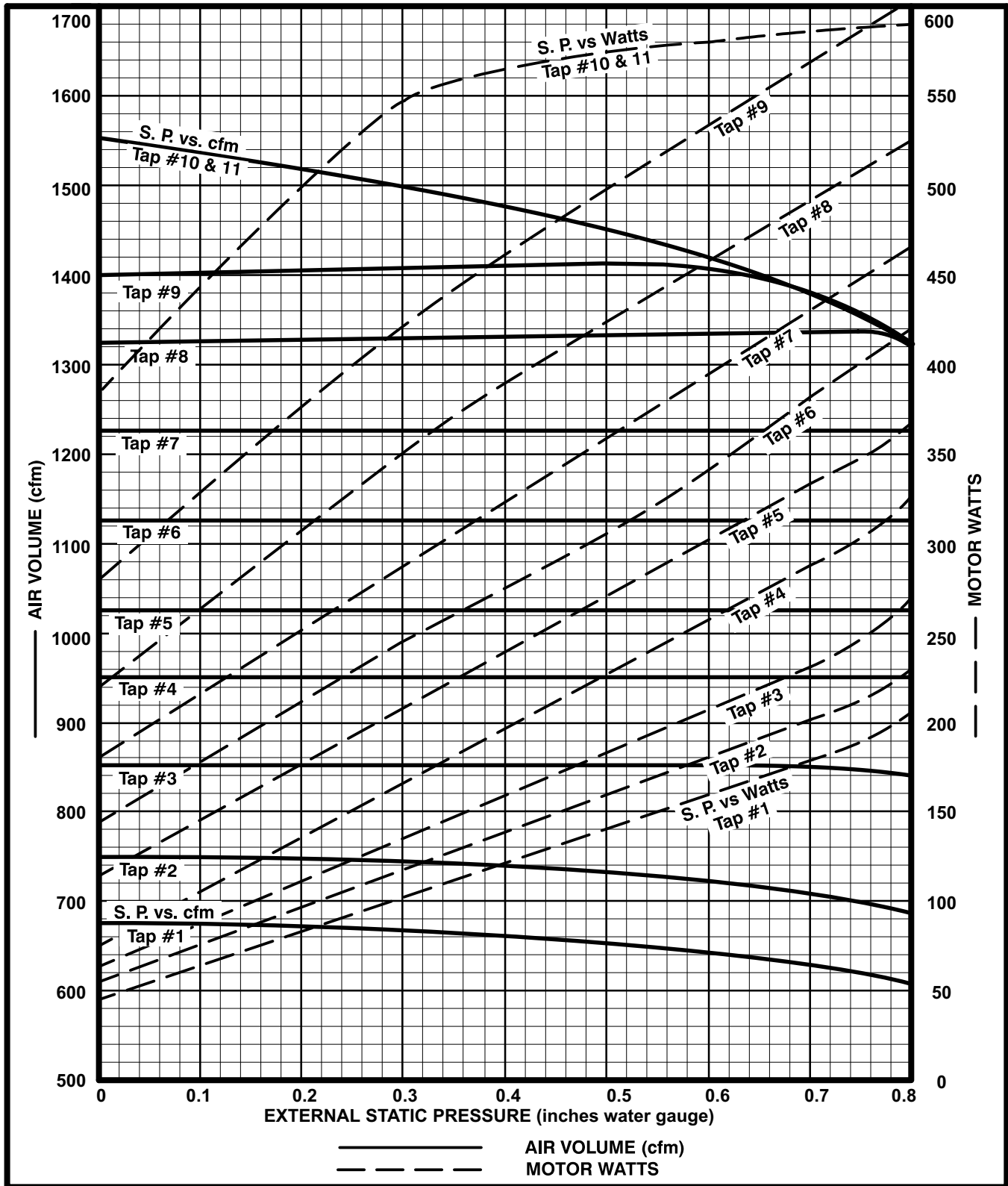

FIGURE 10

TABLE 5
CB21-41 AND CBH21-41 BLOWER PERFORMANCE CURVE



NOTE- All cfm is measured external to the unit with air filter and electric heat .

TABLE 6
CB21-51/65 AND CBH21-51/65 BLOWER PERFORMANCE CURVE
1 Horsepower (ECM) Electronically Commutated Motor

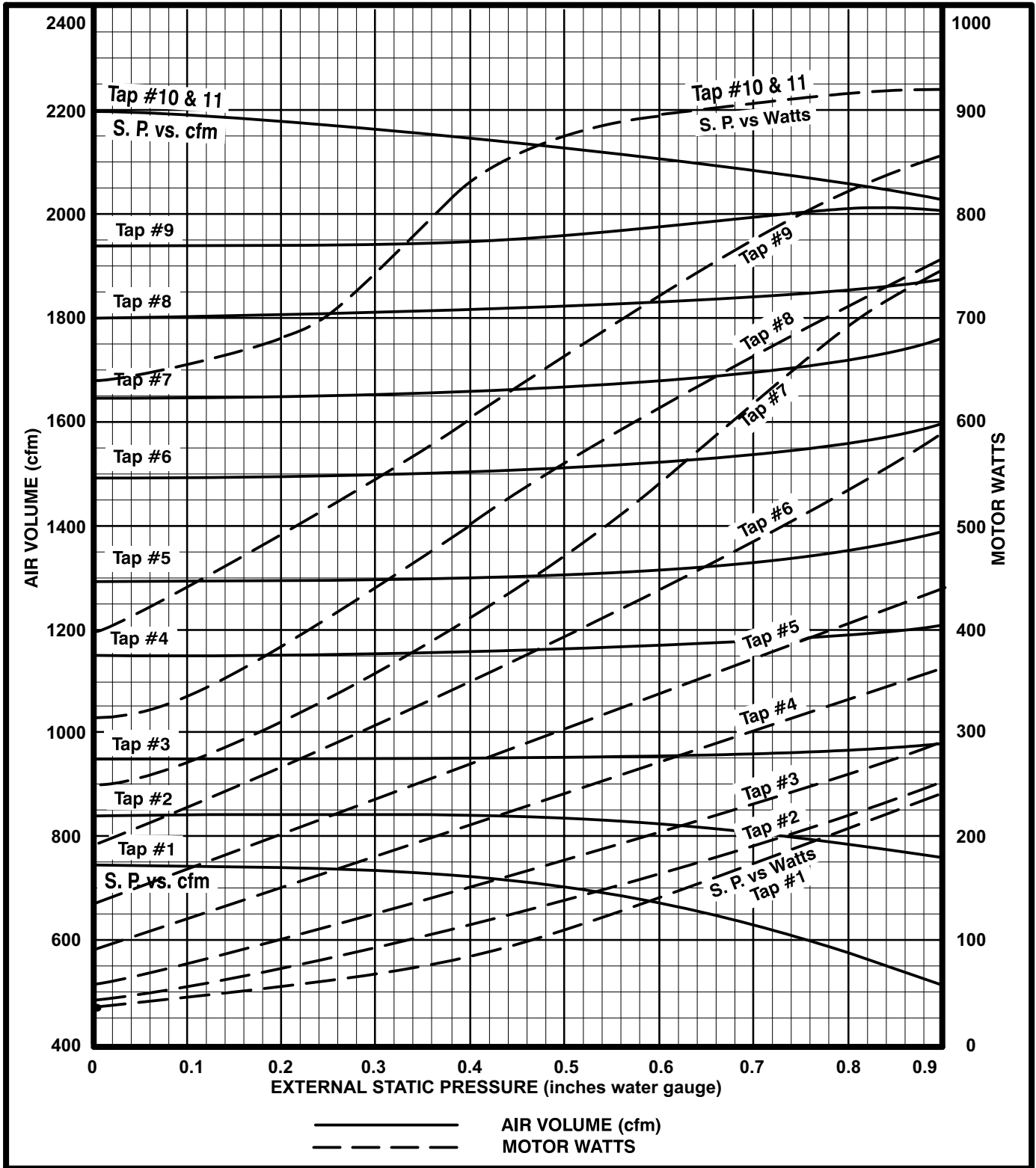

NOTE- All cfm is measured external to the unit with air filter and electric heat .

Motor Startup

The motor is equipped with eleven taps which are driven by the integral controller. The controller is capable of controlling three of the eleven taps. Typically, a low speed tap is energized during outdoor unit low speed cooling operation and when dehumidification is required. A higher speed tap is energized during outdoor unit high speed operation. A third speed tap is selected during heating operation.

The motor controller is driven by thermostat and dehumidification demand from blower drive control A15 and internal sensing devices.

Motor rpm is continually adjusted to maintain constant static pressure against the blower wheel. The controller monitors the static work load on the motor and motor amp-draw to determine the amount of rpm adjustment. Blower rpm may be adjusted any amount in order to maintain a constant cfm as shown in blower ratings table 11. Tables 5 and 6 show how the cfm remains relatively stable over a broad range of static pressure. Since the blower constantly adjusts rpm to maintain a specified cfm, motor rpm is not rated. Hence, the terms “blower speed” and “speed tap” in this manual, on the unit wiring diagram and on blower B3 refer to blower cfm regardless of motor rpm.

Initial Power-up

When line voltage is applied to the ECM, there will be a large inrush of power lasting less than 1/4 second. This inrush charges a bank of DC filter capacitors inside the ECM controller. If the disconnect switch is bounced when the disconnect is closed, the disconnect contacts may become welded. Try not to bounce the disconnect switch when applying power to the unit.

The DC filter capacitors inside the ECM controller are connected electrically to the speed tap wires. The capacitors take approximately 5 minutes to bleed down when the disconnect is opened. For this reason it is necessary to wait at least 5 minutes after turning off power to the unit before attempting to change speed taps.

CAUTION - ELECTRICAL SHOCK HAZARD — DISCONNECT POWER FROM UNIT AND WAIT AT LEAST FIVE MINUTES TO ALLOW CAPACITORS TO DISCHARGE BEFORE ATTEMPTING TO ADJUST MOTOR SPEED TAP SETTINGS. FAILURE TO WAIT MAY CAUSE PERSONAL INJURY OR DEATH.

When the motor begins startup, the motor gently vibrates back and forth for a moment. This is normal. During this time the electronic controller is determining the exact position of the rotor. Once the motor begins turning, the controller slowly eases the motor up to speed (this is called “soft-start”). The motor may take as long as 10-15 seconds to reach full speed. If the motor does not reach 200rpm within 13 seconds, the motor shuts down. Then the motor will immediately attempt a restart. The shut-down feature provides protection in case of a frozen bearing or blocked blower wheel. The motor attempts to start up to eight times. If the motor does not start after the eighth try, the controller locks out. The controller can be reset by momentarily turning off power to the unit.

External Operation (Speed Tap Priority)

Figure 11 shows the two quick-connect jacks (J48 and J49) which connect the motor to the CB21. Jack J48 is the power plug and jack J49 connects the unit controls to the motor. The power plug must be removed to gain access to the speed taps.

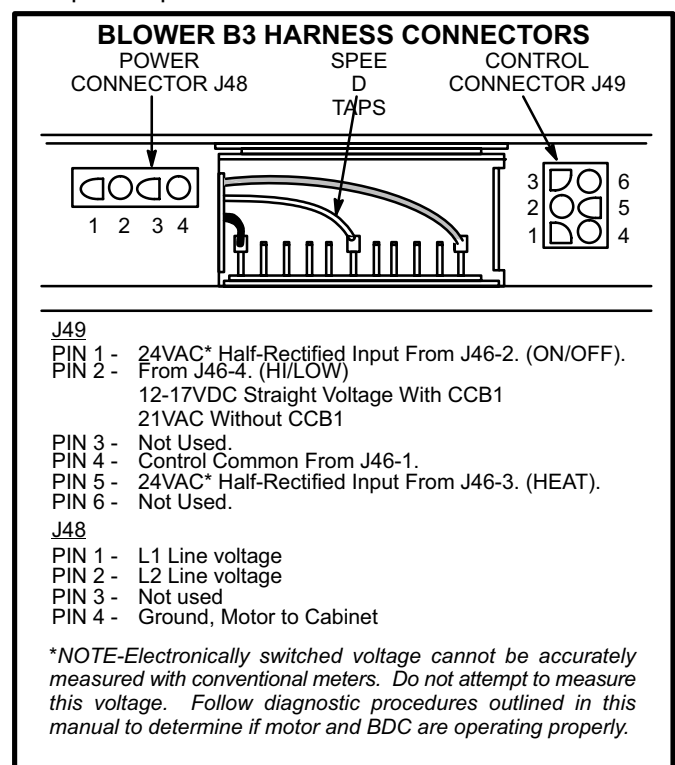

FIGURE 11

Line voltage must be applied to J48 pins 1 and 2 in order for the motor to operate. When control voltage is applied to J49 pin 1 (low speed cooling or during dehumidification), the motor is energized on low speed. When voltage is applied to J49 pin 2 in addition to pin1 (high speed cooling), the blower is energized on high speed. When voltage

is applied to J49 pin 5 (heating demand), the blower is energized on heating speed. The motor assigns priority to J49 pin 5 so that if a call for cooling and a call for heating are concurrent, the call for heating overrides and the blower operates on heating speed.

Blower CFM (Speed) Adjustment

All units are factory wired to the appropriate speed taps in both heat pump and cooling applications with or without electric heat. No field wiring is required. Table 7 shows the factory set blower speeds. All speeds shown are minimums. Do not change motor taps to operate at speeds lower than those shown in table 8. Maximum cooling speed taps are shown in figure 9. Recommended speed taps for other matchups are shown in table 10. Blower motor and cfm performance ratings are shown in table 11.

TABLE 7

FACTORY BLOWER SPEED SETTINGS			
Unit	Low Speed Cooling Tap	High Speed Cooling Tap	Heating Speed Tap
CB21-41 CBH21-41	3	5	6
CB21-51 CBH21-51	2	7	6
CB21-65 CBH21-65	4	8	7

TABLE 8

MINIMUM BLOWER SPEED TAPS FOR HEATING				
HEAT PUMP	BLOWER COIL	ELECTRIC HEAT ONLY	HEAT PUMP ONLY	HEAT PUMP WITH ELEC. HEAT
HP21-411	CB21-41-1P CBH21-41-1P	8	6	8
HP21-511	CB21-51-1P B21/CH21-51-1P	8	6	8
HP21-651	CB21-65-1P B21/CH21-65-1P	8	7	9

TABLE 9

MAXIMUM BLOWER SPEED TAPS FOR COOLING		
HEAT PUMP	BLOWER COIL	WITH HEAT PUMP
HP21-411	CB21-41-1P CBH21-41-1P	5
HP21-511	CB21-51-1P B21/CH21-51-1P	7
HP21-651	CB21-65-1P B21/CH21-65-1P	8

CAUTION - ELECTRICAL SHOCK HAZARD — DISCONNECT POWER FROM UNIT AND WAIT AT LEAST FIVE MINUTES TO ALLOW CAPACITORS TO DISCHARGE BEFORE ATTEMPTING TO ADJUST MOTOR SPEED TAP SETTINGS. FAILURE TO WAIT MAY CAUSE PERSONAL INJURY OR DEATH.

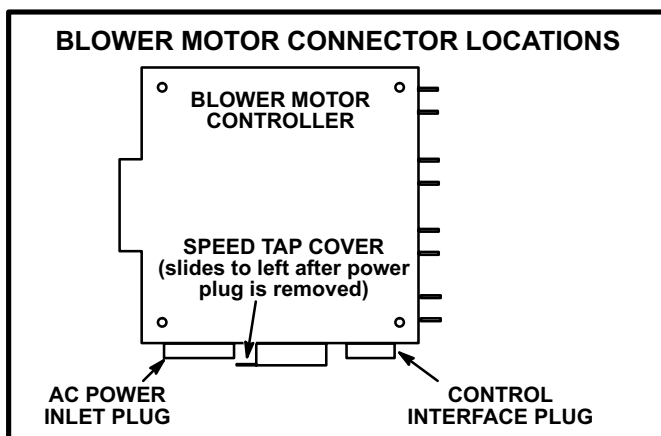

FIGURE 12

Use the following procedure to change blower speed selection for high, low or heat speed selection:

- 1- Disconnect line voltage from unit.
- 2- Disconnect AC power plug P48 from motor/controller. See figure 11.
- 3- Slide tap cover toward AC power plug. See figure 12.
- 4- Remove the appropriate speed connector and place it on the proper tap. See figure 13.
- 5- When all connections are made to proper taps, close tap cover and reconnect AC power plug to motor/controller and reconnect line voltage to unit.

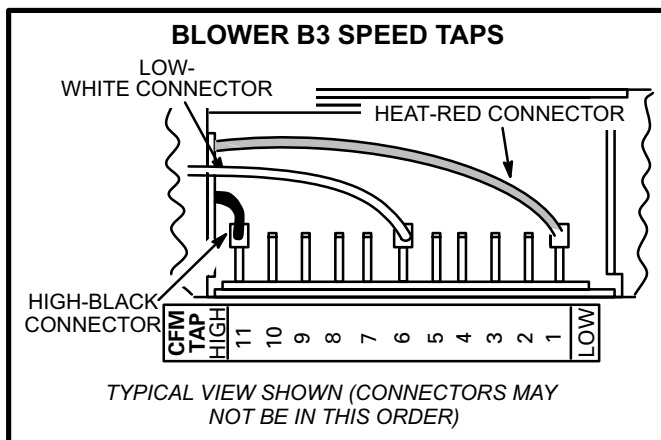

FIGURE 13

If any of the tap wires are left disconnected, the motor reverts to default speed taps. If the black or red wires are left off, the motor defaults to tap 11. If the white wire is left off, the motor defaults to tap 5.

TABLE 10

RECOMMENDED BLOWER SPEED TAP SETTINGS FOR CB21 SERIES UNITS				
Blower Coil Unit Model Number	Outdoor Unit Model Number	*Recommended Blower Speed Tap Settings		
		Cooling High Speed	Cooling Low Speed	Heating Speed **Heat Pump Only
CB21-41 CBH21-41	HP14-261/411V, HP14-213/413V	5	3	4
	HP19-311, HP21-411, HP21-413	5	3	6
	HP18-461V, HP20-461	6	3	7
	HP18-411V, HP18-413V, HP20-411, HP19-411, HP19-413, HP22-411	7	3	6
	HS18-411, HS18-413, HS18-461, HS18-463, HS16-411V, HS16-461V, HS19-411V, HS19-413V, HS19-461V, HS19-463V, HS22-411V, HS22-461V, HS14-411V, HS14-413V	7	3	**
CB21-51 CBH21-51	HP19-411, HP19-413, HP22-411	5	2	6
	HP18-461V, HP19-461, HP19-463, HP20-461, HP22-461	6	2	7
	HP18-511V, HP18-513V, HP19-511, HP19-513, HP14-311/511V, HP14-313/513V, HP21-511, HP21-513	7	2	6
	HS18-411, HS18-413, HS16-411V, HS19-411V, HS19-413V, HS22-411V	5	2	**
	HS18-461, HS18-463, HS18-511, HS18-513, HS16-461V, HS16-511V, HS16-513V, HS19-461V, HS19-463V, HS19-511V, HS19-513V, HS22-461V	6	2	**
	HS14-411V, HS14-413V	6	2	**
	HS14-511V, HS14-513V	7	2	**
	HS14-651V, HS14-653V	8	3	**
CB21-65 CBH21-65	HP18-651V, HP18-653V, HP19-511, HP19-513, HP19-651, HP19-653, HP14-411/651V, HP14-413/653V, HP21-651, HP21-653	8	4	7
	HS18-511, HS18-513, HS18-651, HS18-653, HS16-511V, HS16-513V, HS16-651V, HS19-511V, HS19-513V, HS19-651V, HS19-653V, HS14-511V, HS14-513V, HS14-651V, HS14-653V	8	4	**

*Necessary to achieve published ratings. See installation instructions for methods of changing speed.

**Speeds shown for heat pump match without electric heat. For combinations with electric heat, see ECB21 installation instructions for appropriate speed settings and method of changing speed taps.

TABLE 11

CB21 AND CBH21 BLOWER PERFORMANCE												
Unit*		Air Volume (cfm) and Electrical Characteristics @ Various Speeds										
		Speed Tap 1	Speed Tap 2	Speed Tap 3	Speed Tap 4	Speed Tap 5	Speed Tap 6	Speed Tap 7	Speed Tap 8	Speed Tap 9	Speed Tap 10	Speed Tap 11
CB21-41 CBH21-41	cfm	675	750	850	925	1025	1125	1225	1325	1400	1550	1550
	LRA	Not Applicable, Controller locks out when motor stalls.										
	FLA range	Refer to table 5										
CB21-51, CBH21-51 CB21-65, CBH21-65	cfm	750	850	950	1150	1300	1500	1650	1800	1950	2100	2100
	LRA	Not Applicable, Controller locks out when motor stalls.										
	FLA range	Refer to table 6										

*Operating at 0.00 thru 0.60 in. wg. External Static Pressure.

TABLE 12

CB21 SERIES UNITS - BLOWER MOTOR ACTIVE TAPS*					
Unit		CB21 TB1 Terminal Strip Jumpers Required	Active Blower Tap		
Indoor	Outdoor		Cooling Mode		Heating Mode
			No CCB1 Demand	With CCB1 Demand	
With CCB1 Humidity Control	Two-Speed Heat Pump	None	Low Compressor - White Tap High Compressor - Black Tap Fan Only - White Tap	High Compressor - White Tap Fan Only - White Tap	All Heating - Red Tap Fan Only - Red Tap
	Two-Speed Condensing Unit	O to R	Low Compressor - White Tap High Compressor - Black Tap Fan Only - White Tap	High Compressor - White Tap Fan Only - White Tap	All Heating - Red Tap Fan Only - White Tap
	Single-Speed Heat Pump	Y1 to Y2	Compressor - Black Tap Fan Only - White Tap	Compressor - White Tap Fan Only - White Tap	All Heating - Red Tap Fan Only - Red Tap
	Single-Speed Condensing Unit	O to R and Y1 to Y2	Compressor - Black Tap Fan Only - White Tap	Compressor - White Tap Fan Only - White Tap	All Heating - Red Tap Fan Only - White Tap
Without CCB1 Humidity Control	Two-Speed Heat Pump	DS to Y2	Low Compressor - White Tap High Compressor - Black Tap Fan Only - White Tap		All Heating - Red Tap Fan Only - Red Tap
	Two-Speed Condensing Unit	DS to Y2 and O to R	Low Compressor - White Tap High Compressor - Black Tap Fan Only - White Tap		All Heating - Red Tap Fan Only - White Tap
	Single-Speed Heat Pump	DS to Y1	Compressor - Black Tap Fan Only - White Tap		All Heating - Red Tap Fan Only - Red Tap
	Single-Speed Condensing Unit	DS to Y1 and O to R	Compressor - Black Tap Fan Only - White Tap		All Heating - Red Tap Fan Only - White Tap

*Refer to figure 13.

Precautions

If the CB21 or its ECM motor is improperly or inadequately grounded, the ECM motor may cause television interference (commonly known as RF or radio frequency interference). The interference is caused by the internal switching frequency of the motor controller (see figure 14). TV interference may show up as small specks or lines which randomly appear on the TV screen accompanied by pops or clicks in the sound. Before attempting any service, make sure the indoor unit is causing the interference. To check, disconnect power to the indoor unit then check the TV for continued signs of interference.

TV interference may be stopped by making sure the motor is solidly grounded to the cabinet (metal to metal) and by making sure the cabinet is solidly grounded. If TV interference persists, make sure the television (and all affected RF appliances) are moved away from the CB21. Also make sure affected appliances are connected to a separate electrical circuit.

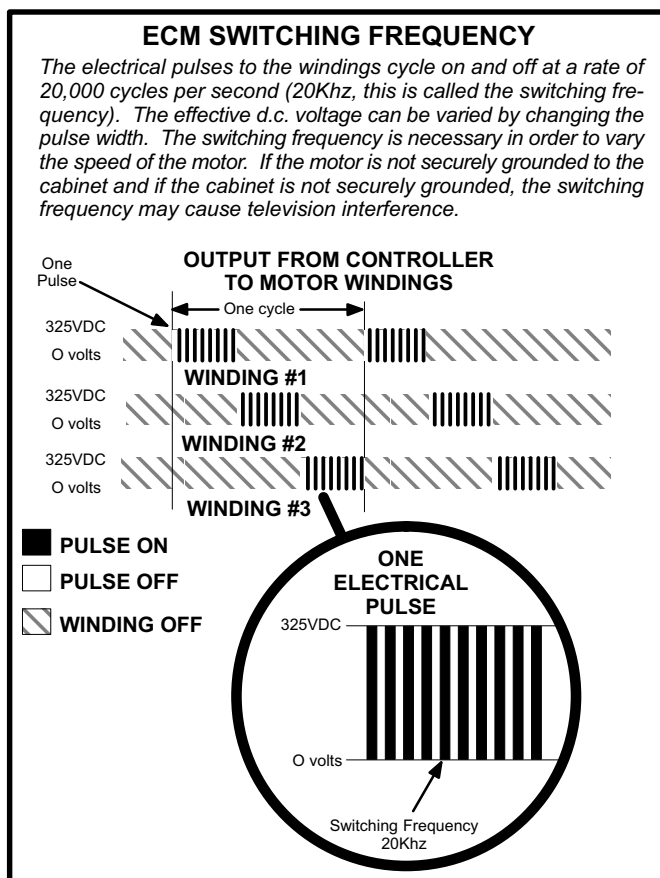
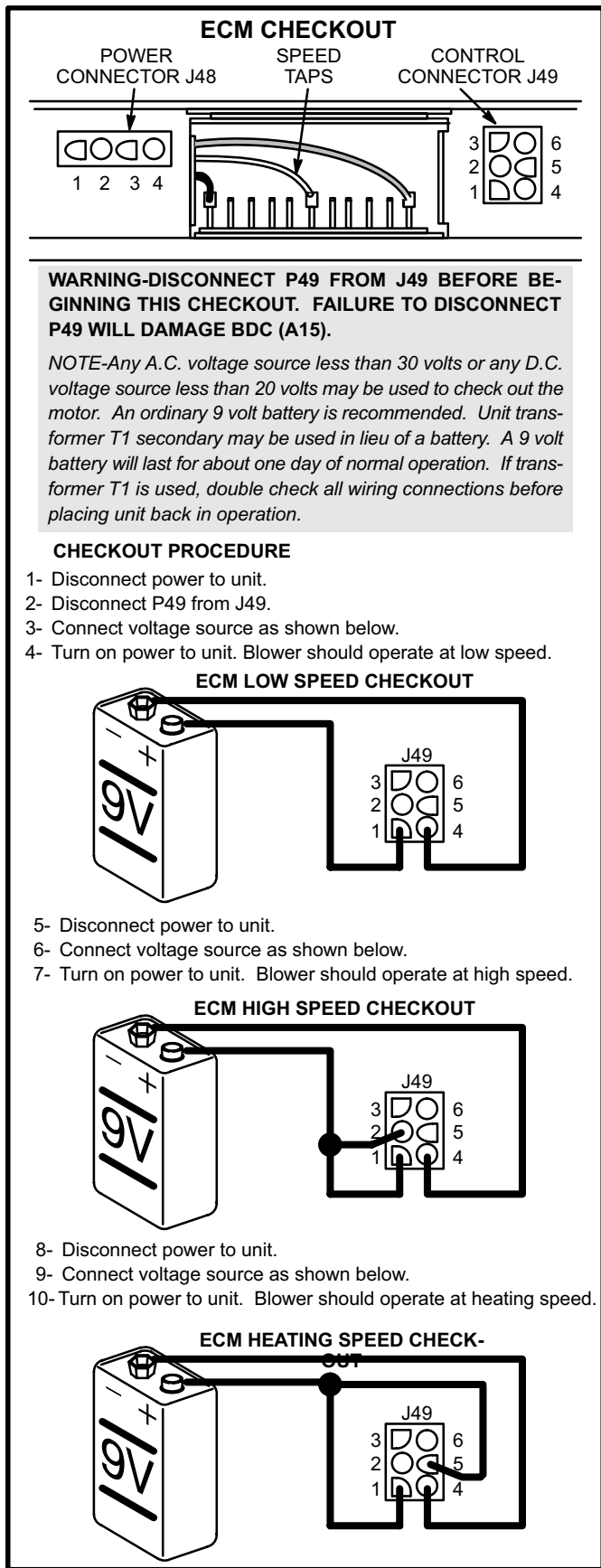

FIGURE 14



**FIGURE
15**

Motor and BDC Checkout

Figure 15 shows the ECM checkout procedure. The checkout procedure may be used to determine if either the ECM (B3) or BDC (A15) must be replaced. Follow the procedure outlined in table 15. If the ECM does not operate properly it must be replaced. If the ECM appears to be operating properly, replace the BDC (A15).

WARNING-DO NOT ATTEMPT TO REPAIR THE ECM (B3) OR BDC (A15). THERE ARE NO FIELD SERVICEABLE PARTS IN EITHER OF THESE COMPONENTS. IF EITHER COMPONENT APPEARS TO BE FAULTY AFTER FOLLOWING THIS CHECKOUT PROCEDURE, SIMPLY REPLACE THE ENTIRE COMPONENT, THEN RECHECK FOR UNIT OPERATION.

H-Coil

All CB21 series units have dual coils arranged in a "V" configuration. Each coil has three rows of copper tubes fitted with ripple-edged aluminum fins. An expansion distributor feeds multiple parallel circuits through the coils.

CB21/CBH21 coils are equipped with flare connections and provisions for field installed internally mounted expansion valves. See table 13. CB21 and CBH21 units require field installed expansion device. Heat pump system matches require externally equalized check/expansion valves. Refer to figure 17 for installation of expansion valve. An adaptor (provided in installation bag assembly) is used between liquid line and expansion valve. Refer to outdoor unit installation instructions for proper application, installation and refrigeration charge for particular systems.

A screen type strainer in the liquid line connector prohibits debris from entering the coil during cooling mode. If the refrigerant system is opened for service, the liquid line connector should be removed and the strainer cleaned.

TABLE 13

COIL UNIT	REFRIGERANT LINE CONNECTIONS			
	LIQUID LINE		VAPOR LINE	
	INCHES	MM	INCHES	MM
CB21/CBH21-41	3/8 male flare	10	3/4 male flare	19
CB21/CBH21-51	3/8 male flare	10	3/4 male flare	19
CB21/CBH21-65	3/8 male flare	10	1-1/8 sweat connection	29

I-RFCIII Flow Control Device

RFCIII is a primary expansion mechanism which controls the flow of refrigerant through the coil in both cooling and heating modes. An RFCIII orifice is factory installed in all 19 series indoor units (CH19 coil is used in combination with B21 blower to make a CBH21-65). All 21 series units use a thermal expansion valve as the primary expansion device. The factory installed RFCIII orifice must be removed when the expansion valve is field installed.

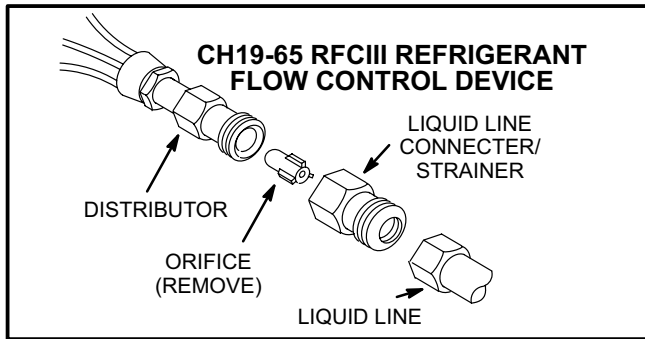

FIGURE 16

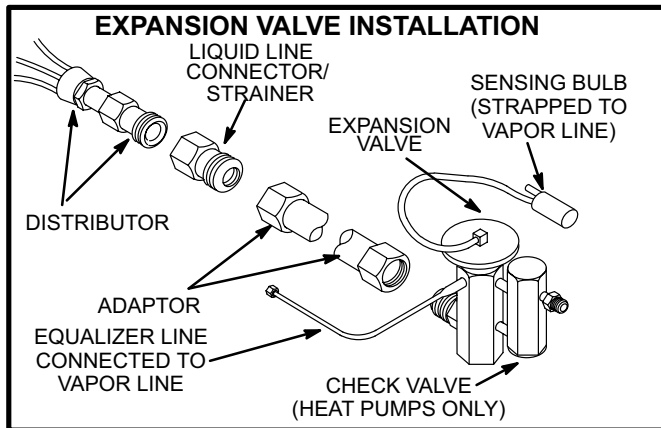

FIGURE 17

WARNING-RFC ORIFICE MUST BE REMOVED FROM CH19-65 COIL WHEN USED WITH 21 SERIES COMPONENTS. IF THE ORIFICE IS LEFT IN PLACE, SYSTEM PERFORMANCE MAY BE ADVERSELY AFFECTED.

The components used in RFCIII systems are shown in figure 16. When an expansion valve is used, the same components shown in figure 16 are used *but the orifice must be removed (see figure 17)*. RFCIII liquid line connector/strainer and distributor are left in place and the liquid line connects to the expansion valve check valve.

IV-OPTIONAL ECB21 ELECTRIC HEAT

A-Electric Heat Components

ECB21 parts arrangement is shown in figures 18, 19, 20 and 21. All ECB21 units consist of electric heating elements exposed directly to the airstream. Elements are sequenced on and off by heat relays in response to thermostat demand.

B-Matchups and Ratings

Tables 14 and 15 show all possible CB21 to ECB21 matchups. Also shown in the tables are ECB21 electrical ratings.

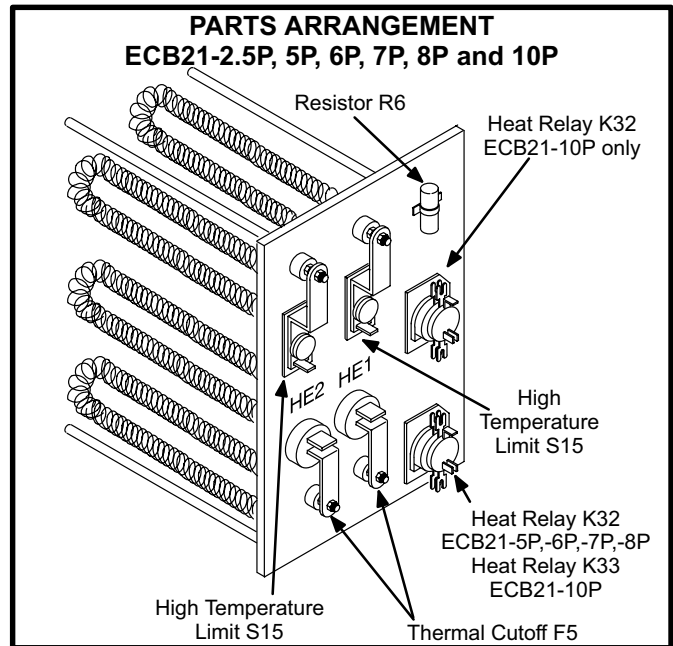

FIGURE 18

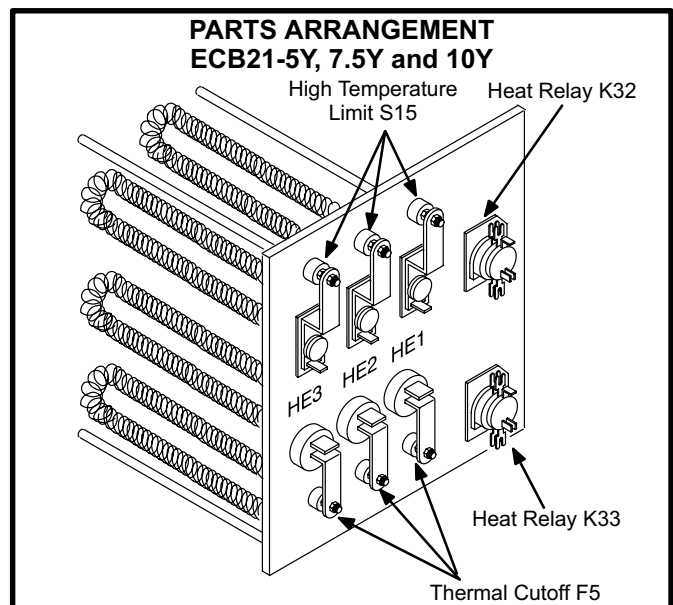

FIGURE 19

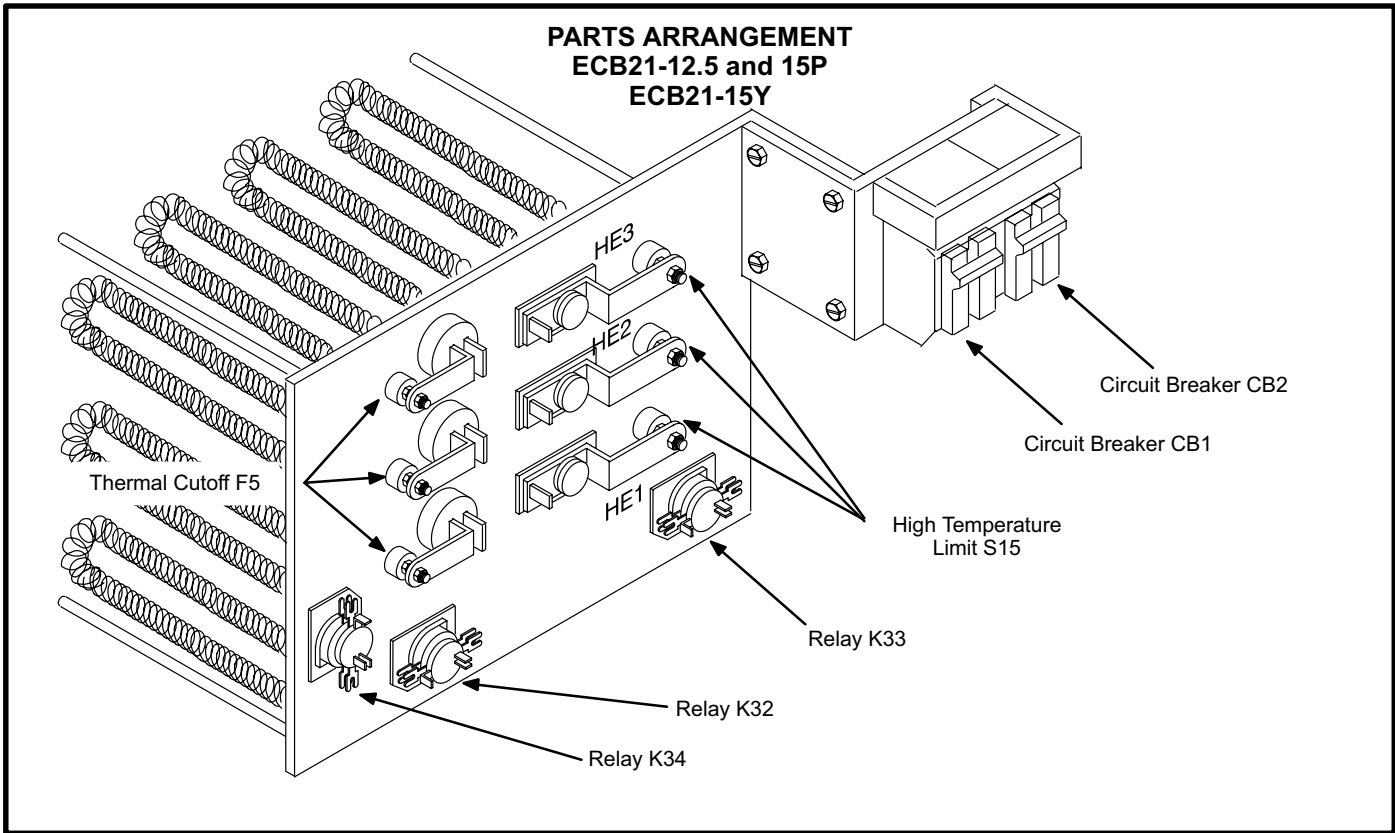

FIGURE 20

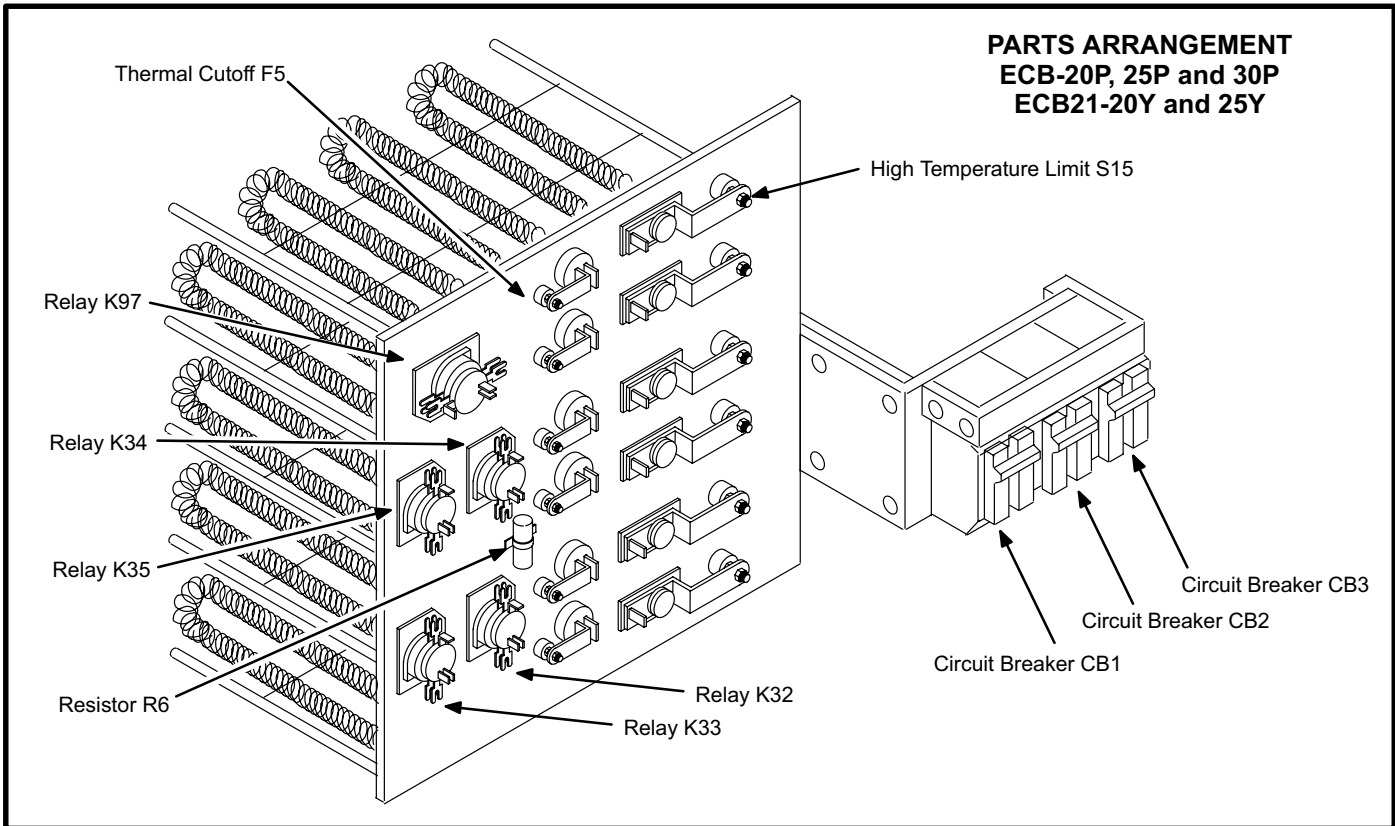

FIGURE 21

CB21 & CBH21 - 41 OPTIONAL ELECTRIC HEAT DATA (TABLE 14)

Electric Heat Unit Model No.	No. of Steps & phase	Volts Input	kw Input	Btuh Input	*Minimum Circuit Ampacity		
					Circuit 1**	Circuit 2***	Circuit 3
ECB21-5	1 step 1 phase	208	3.8	12,800	6.8	22.7	----
		220	4.2	14,300	6.8	23.9	----
		230	4.6	15,700	6.8	25.0	----
		240	5.0	17,100	6.8	26.0	----
ECB21-5	3 steps 3 phase	208	3.8	12,800	6.8	13.0	----
		220	4.2	14,300	6.8	13.9	----
		230	4.6	15,700	6.8	14.4	----
		240	5.0	17,100	6.8	15.0	----
ECB21-6	2 steps 1 phase	208	4.5	15,400	6.8	27.2	----
		220	5.0	17,100	6.8	28.4	----
		230	5.5	18,800	6.8	30.0	----
		240	6.0	20,500	6.8	31.3	----
ECB21-7	2 steps 1 phase	208	5.3	17,900	6.8	31.7	----
		220	5.9	20,100	6.8	33.5	----
		230	6.4	21,900	6.8	34.9	----
		240	7.0	23,900	6.8	36.5	----
ECB21-7.5	3 steps 3 phase	208	5.6	19,200	6.8	19.5	----
		220	6.3	21,500	6.8	20.6	----
		230	6.9	23,500	6.8	21.6	----
		240	7.5	25,600	6.8	22.5	----
ECB21-8	2 steps 1 phase	208	6.0	20,500	6.8	36.2	----
		220	6.7	22,900	6.8	38.1	----
		230	7.3	25,100	6.8	39.9	----
		240	8.0	27,300	6.8	41.7	----
ECB21-10	2 steps 1 phase	208	7.5	25,600	6.8	45.0	----
		220	8.4	28,700	6.8	47.7	----
		230	9.2	31,400	6.8	49.9	----
		240	10.0	34,100	6.8	52.2	----
ECB21-10	3 steps 3 phase	208	7.5	25,600	6.8	26.0	----
		220	8.4	28,700	6.8	27.5	----
		230	9.2	31,400	6.8	28.9	----
		240	10.0	34,100	6.8	30.2	----
ECB21-12.5	3 steps 1 phase	208	9.4	32,000	6.8	37.7	18.9
		220	10.5	35,800	6.8	39.9	19.9
		230	11.5	39,200	6.8	41.6	20.8
		240	12.5	42,600	6.8	43.3	21.8
ECB21-15	3 steps 1 phase	208	11.3	38,400	6.8	45.2	22.7
		220	12.6	43,000	6.8	47.7	23.9
		230	13.5	47,000	6.8	49.9	25.0
		240	15.0	51,200	6.8	52.2	26.0
ECB21-15	3 steps 3 phase	208	11.3	38,400	6.8	39.2	----
		220	12.6	43,000	6.8	41.3	----
		230	13.5	47,000	6.8	43.3	----
		240	15.0	51,200	6.8	45.2	----
ECB21-20	4 steps 1 phase	208	15.0	51,200	6.8	45.0	45.0
		220	16.8	57,300	6.8	47.8	47.8
		230	18.4	62,700	6.8	49.9	49.9
		240	20.0	68,200	6.8	52.2	52.2

*Refer to National Electrical Code manual to determine wire, fuse and disconnect size requirements. Use wires suitable for at least 167°F.

**Unit Circuit Ampacity without electric heat.

***1st stage heating element.

CB21 & CBH21 - 51 & 65 OPTIONAL ELECTRIC HEAT DATA (TABLE 15)

Electric Heat Unit Model No.	No. of Steps & phase	Volts Input	kw Input	Btuh Input	*Minimum Circuit Ampacity			
					Circuit 1	Circuit 2	Circuit 3	Circuit 4
ECB21-5	1 step 1 phase	208	3.8	12,800	11.0	22.7	----	----
		220	4.2	14,300	11.0	23.9	----	----
		230	4.6	15,700	11.0	25.0	----	----
		240	5.0	17,100	11.0	26.0	----	----
ECB21-5	1 step 3 phase	208	3.8	12,800	11.0	13.0	----	----
		220	4.2	14,300	11.0	13.9	----	----
		230	4.6	15,700	11.0	14.4	----	----
		240	5.0	17,100	11.0	15.0	----	----
ECB21-6	2 steps 1 phase	208	4.5	15,400	11.0	27.2	----	----
		220	5.0	17,100	11.0	28.4	----	----
		230	5.5	18,800	11.0	30.0	----	----
		240	6.0	20,500	11.0	31.3	----	----
ECB21-7	2 steps 1 phase	208	5.3	17,900	11.0	31.7	----	----
		220	5.9	20,100	11.0	33.5	----	----
		230	6.4	21,900	11.0	34.9	----	----
		240	7.0	23,900	11.0	36.5	----	----
ECB21-7.5	3 steps 3 phase	208	5.6	19,200	11.0	19.5	----	----
		220	6.3	21,500	11.0	20.6	----	----
		230	6.9	23,500	11.0	21.6	----	----
		240	7.5	25,600	11.0	22.5	----	----
ECB21-8	2 steps 1 phase	208	6.0	20,500	11.0	36.2	----	----
		220	6.7	22,900	11.0	38.1	----	----
		230	7.3	25,100	11.0	39.9	----	----
		240	8.0	27,300	11.0	41.7	----	----
ECB21-10	2 steps 1 phase	208	7.5	25,600	11.0	45.0	----	----
		220	8.4	28,700	11.0	47.7	----	----
		230	9.2	31,400	11.0	49.9	----	----
		240	10.0	34,100	11.0	52.2	----	----
ECB21-10	3 steps 3 phase	208	7.5	25,600	11.0	26.0	----	----
		220	8.4	28,700	11.0	27.5	----	----
		230	9.2	31,400	11.0	28.9	----	----
		240	10.0	34,100	11.0	30.2	----	----
ECB21-12.5	3 steps 1 phase	208	9.4	32,000	11.0	37.7	18.9	----
		220	10.5	35,800	11.0	39.9	19.9	----
		230	11.5	39,200	11.0	41.6	20.8	----
		240	12.5	42,600	11.0	43.4	21.8	----
ECB21-15	3 steps 1 phase	208	11.3	38,400	11.0	45.2	22.7	----
		220	12.6	43,000	11.0	47.7	23.9	----
		230	13.5	47,000	11.0	49.9	25.0	----
		240	15.0	51,200	11.0	52.2	26.0	----
ECB21-15	3 steps 3 phase	208	11.3	38,400	11.0	39.2	----	----
		220	12.6	43,000	11.0	41.3	----	----
		230	13.5	47,000	11.0	43.3	----	----
		240	15.0	51,200	11.0	45.2	----	----
ECB21-20	4 steps 1 phase	208	15.0	51,200	11.0	45.0	45.0	----
		220	16.8	57,300	11.0	47.8	47.8	----
		230	18.4	62,700	11.0	49.9	49.9	----
		240	20.0	68,200	11.0	52.2	52.2	----
ECB21-20	6 steps 3 phase	208	15.0	51,200	11.0	26.0	26.0	----
		220	16.8	57,300	11.0	27.6	27.6	----
		230	18.4	62,700	11.0	28.9	28.9	----
		240	20.0	68,200	11.0	30.2	30.2	----
ECB21-25	5 steps 1 phase	208	18.8	64,100	11.0	45.0	45.0	22.7
		220	21.0	71,700	11.0	47.8	47.8	23.9
		230	23.0	78,300	11.0	49.9	49.9	25.0
		240	25.0	85,300	11.0	52.2	52.2	26.0
ECB21-25	6 steps 3 phase	208	18.8	64,100	11.0	32.7	32.7	----
		220	21.0	71,700	11.0	34.4	34.4	----
		230	23.0	78,300	11.0	36.0	36.0	----
		240	25.0	85,300	11.0	37.7	37.7	----
ECB21-30	6 steps 1 phase	208	22.5	76,900	11.0	45.0	45.0	45.0
		220	25.2	86,000	11.0	47.8	47.8	47.8
		230	27.5	94,000	11.0	49.9	49.9	49.9
		240	30.0	102,400	11.0	52.2	52.2	52.2

*Refer to National Electrical Code manual to determine wire, fuse and disconnect size requirements. Use wires suitable for at least 167°F.

1-Thermal (Heat) Relay

Thermal sequencing (heat) relays are used to energize heating elements in all ECB21 series units. A heat relay is a N.O. relay with a resistive element for a coil and a bimetal disk actuating the contacts. When the relay is energized, the internal resistance heats the bimetal disk causing the contacts to close. When the relay is de-energized, the disk cools and the contacts open.

A sequencing relay has multiple contacts. Each set of contacts is connected to a separate bimetal disk. When the relay is energized, internal resistance heats the bimetal disks at different rates causing the contacts to close at different times. The contacts are calibrated to operate on a first on/last off basis. In some heat relays, all or part of the contacts may be physically connected (not electrically connected) together so that they open and close at the same time. Other re-

lays have two resistive coils; each with its own set of contacts. These relays operate as two independent relays. Figure 22 shows a typical heat relay. Table 16 describes the heat relays used in ECB21 series units.

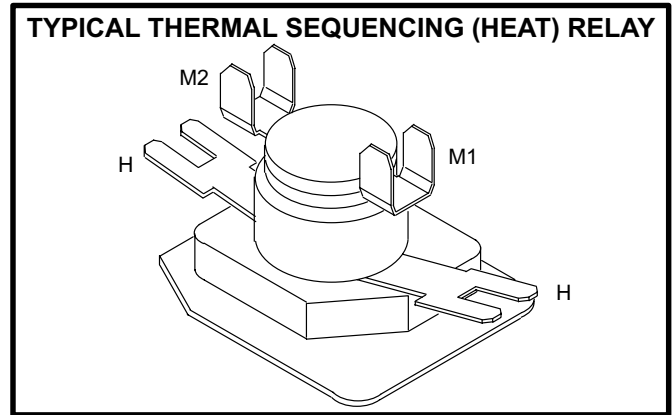
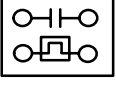
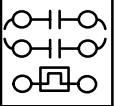
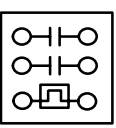
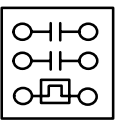

FIGURE 22

TABLE 16

Heat Relay	Operation	Coil	ECB21 USAGE*				
			K32	K33	K34	K35	K97
M2  M1 H	ONE TIMING M1-M2 closes 1-60 sec. after H-H is energized and opens 1-45 sec. after H-H is de-energized.	24VAC	ECB21-5-P	---	---	---	---
			---	ECB21-10-P	---	---	---
			---	---	ECB21-12.5-P	---	---
			---	---	ECB21-15-P	---	ECB21-30-P
M1  M2 M3 M4 H	SINGLE TIMING Both sets of contacts actuate together. Contacts close 1-60 sec. after H-H is energized and open 1-45 sec. after H-H is de-energized.	24VAC	---	---	ECB21-20-P	---	---
			ECB21-25-P	---	---	---	---
			ECB21-30-P	---	---	---	---
M2  M1 M3 M4 H	TWO TIMINGS CONTROL VOLTAGE COIL Both sets of contacts close 1-110 after H-H is energized and open 1-110 sec. after H-H is de-energized. Terminals M1-M2 operate on a first on last off basis.	24VAC	ECB21-6-P	---	---	---	---
			ECB21-7-P	---	---	---	---
			ECB21-8-P	---	---	---	---
			ECB21-10-P	---	---	---	---
			ECB21-12.5-P	ECB21-12.5-P	---	---	---
			ECB21-15-P	ECB21-15-P	---	---	---
			ECB21-20-P	ECB21-20-P	---	---	---
			---	ECB21-25-P	---	ECB21-25-P	---
			---	ECB21-30-P	---	ECB21-30-P	---
			ECB21-5-Y	ECB21-5-Y	---	---	---
			ECB21-7.5-Y	ECB21-7.5-Y	---	---	---
			ECB21-10-Y	ECB21-10-Y	---	---	---
ECB21-15-Y	ECB21-15-Y	---	---	---			
ECB21-20-Y	ECB21-20-Y	ECB21-20-Y	ECB21-20-Y	ECB21-20-Y			
ECB21-25-Y	ECB21-25-Y	ECB21-25-Y	ECB21-25-Y	ECB21-25-Y			
M2  M1 M3 M4 H	TWO TIMINGS LINE VOLTAGE COIL Both sets of contacts close 1-110 after H-H is energized and open 1-110 sec. after H-H is de-energized. Terminals M1-M2 operate on a first on last off basis.	240VAC	---	---	ECB21-25-P	---	---
			---	---	ECB21-30-P	---	---

*Refer to Unit Wiring Diagram.

2-Resistor R6

ECB21 series units have one or two thermal (heat) relays connected directly to the indoor thermostat (terminal W1.) A resistor is used in parallel with the heat relay (K32) coil in all applications which use a single heat relay connected to thermostat demand (for example, refer to ECB21-5-P diagram in back of this manual). If two heat relays are connected to the thermostat, the relays are connected in parallel and no resistor is used (for example, refer to the ECB21-5-Y unit wiring diagram in back of this manual).

TABLE 17

Units Equipped with Resistor R6	Resistor Rating
ECB21-5-P	150 ohm ± 10% 10 watt
ECB21-6-P	
ECB21-7-P	
ECB21-8-P	
ECB21-10-P	
ECB21-25-P	
ECB21-30-P	

The resistor reduces the effects of inrush current on the thermostat. Heat relays used in ECB21 series units draw approximately 0.7 amps each immediately after being energized. As the relay coil heats and resistance builds, the current subsides. Within a few seconds after being energized, the current is reduced to minimum level (approximately 0.18 amps each). The resistors used in ECB21 series units are shown in Table 17. The resistor is located on the ECB21 control panel.

3-Heating Elements

Optional ECB21 electric heat is composed of helix wound nichrome bare heating elements which are exposed directly to the airstream. Heating elements are energized directly by the heat relays. Once energized, heat transfer is instantaneous. Small kw units use a single heating element connected to line voltage by way of a heat relay and safety limits. All other units use multiple small kw elements connected in parallel. The kw rating of each element is added together to reach the total kw rating of the unit. Each element is energized independently by a thermal sequencing (heat) relay and is protected by safety limits. Heating elements used in ECB21 series units are listed in table 18.

TABLE 18

Unit	Total Watts	Elements	
		Number of Elements	Watts Each
ECB21-5-P	5000 @ 240V	1	5000
ECB21-6-P	6000 @ 240V	2	3000
ECB21-7-P	7000 @ 240V	2	3500
ECB21-8-P	8000 @ 240V	2	4000
ECB21-10-P	10000 @ 240V	2	5000
ECB21-12.5-P	12500 @ 240V	3	4167
ECB21-15-P	15000 @ 240V	3	5000
ECB21-20-P	20000 @ 240V	4	5000
ECB21-25-P	25000 @ 240V	5	5000
ECB21-30-P	30000 @ 240V	6	5000
ECB21-5-Y	5000 @ 240V	3	1667
ECB21-7.5-Y	7500 @ 240V	3	2500
ECB21-10-Y	10000 @ 240V	3	3333
ECB21-15-Y	15000 @ 240V	3	5000
ECB21-20-Y	20000 @ 240V	6	3333
ECB21-25-Y	25000 @ 240V	6	4167

4-High Temperature (Thermal) Cutoff F5

All ECB21 series units use a high temperature (thermal) cutoff fuse connected in series with each element (figure 23). The fuse provides secondary high temperature protection to each element. The fuses are ceramic non-resettable fusible links which must be replaced after being tripped. Each cutoff is factory preset to open at 333°F ± 3°F.

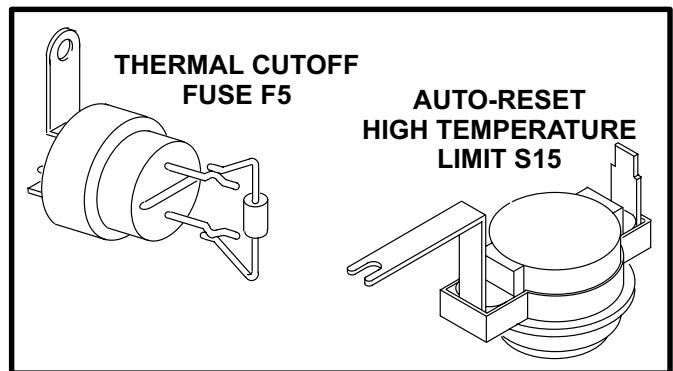

FIGURE 23

5-High Temperature Limits S15

Each ECB21 uses an auto-reset type high temperature limit connected in series with each heating element (figure 23). The high temperature limit is used as a primary limit. If the switch exceeds its factory preset limit (table 19), it opens and cuts out only the element it is connected to.

TABLE 19

ECB21 High Temperature Limit Control S15		
Unit	No. of Limits	Description
ECB21-5-P	1	SPST Normally Closed Open @ 150°F ± 5°F on rise Close @ 115°F ± 7°F on rise auto-reset
ECB21-6-P	2	
ECB21-7-P	2	
ECB21-8-P	2	
ECB21-10-P	2	
ECB21-12.5-P	3	
ECB21-15-P	3	
ECB21-25-P	5	
ECB21-5-Y	3	
ECB21-7.5-Y	3	
ECB21-10-Y	3	
ECB21-15-Y	3	
ECB21-20-Y	6	
ECB21-25-Y	6	
ECB21-20-P	4	SPST Normally Closed Open @ 150°F ± 5°F on rise Close @ 110°F ± 7°F on rise auto-reset
ECB21-30-P	6	SPST Normally Closed Open @ 140°F ± 5°F on rise Close @ 105°F ± 7°F on rise auto-reset

6-Circuit Breakers CB1, CB2, CB3

Larger sized 208/230 volt single and three-phase units (12.5kw and larger) are equipped with circuit breakers for line voltage overcurrent protection. Circuit breakers used in ECB21 series units are shown in table 20.

The ECB21 circuit breakers are connected to line voltage and are wired in parallel with each other and unit circuit breaker CB6. With ECB21 installed CB1, CB2 and CB3 are physically located adjacent to unit circuit breaker CB6.

TABLE 20

ECB21 ELECTRIC HEAT CIRCUIT BREAKER RATINGS			
Unit	Circuit Breaker (CB1)	Circuit Breaker 2 (CB2)	Circuit Breaker 3 (CB3)
ECB21-12.5-P	2 pole 45 amp 120/240vac	2 pole 25 amp 120/240vac	---
ECB21-15-P	2 pole 60 amp 120/240vac	2 pole 30 amp 120/240vac	---
ECB21-20-P	2 pole 60 amp 120/240vac	2 pole 60 amp 120/240vac	---
ECB21-25-P	2 pole 60 amp 120/240vac	2 pole 60 amp 120/240vac	2 pole 30 amp 120/240vac
ECB21-30-P	2 pole 60 amp 120/240vac	2 pole 60 amp 120/240vac	2 pole 60 amp 120/240vac
ECB21-15-Y	3 pole 50 amp 240vac	---	---
ECB21-20-Y	3 pole 35 amp 240vac	3 pole 35 amp 240vac	---
ECB21-25-Y	3 pole 40 amp 240vac	3 pole 40 amp 240vac	---

V-WIRING DIAGRAMS AND OPERATING SEQUENCE

A-Field Wiring

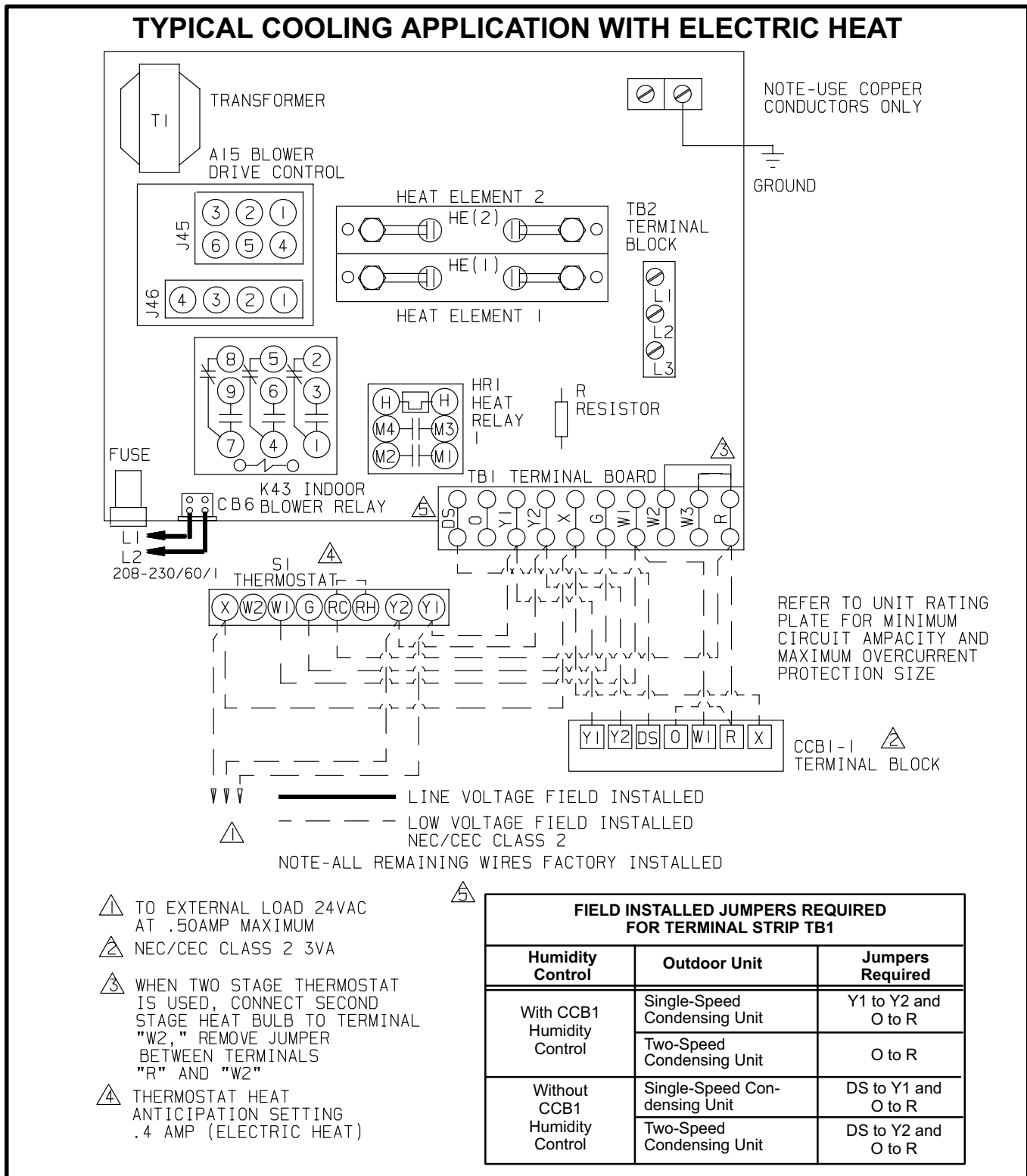
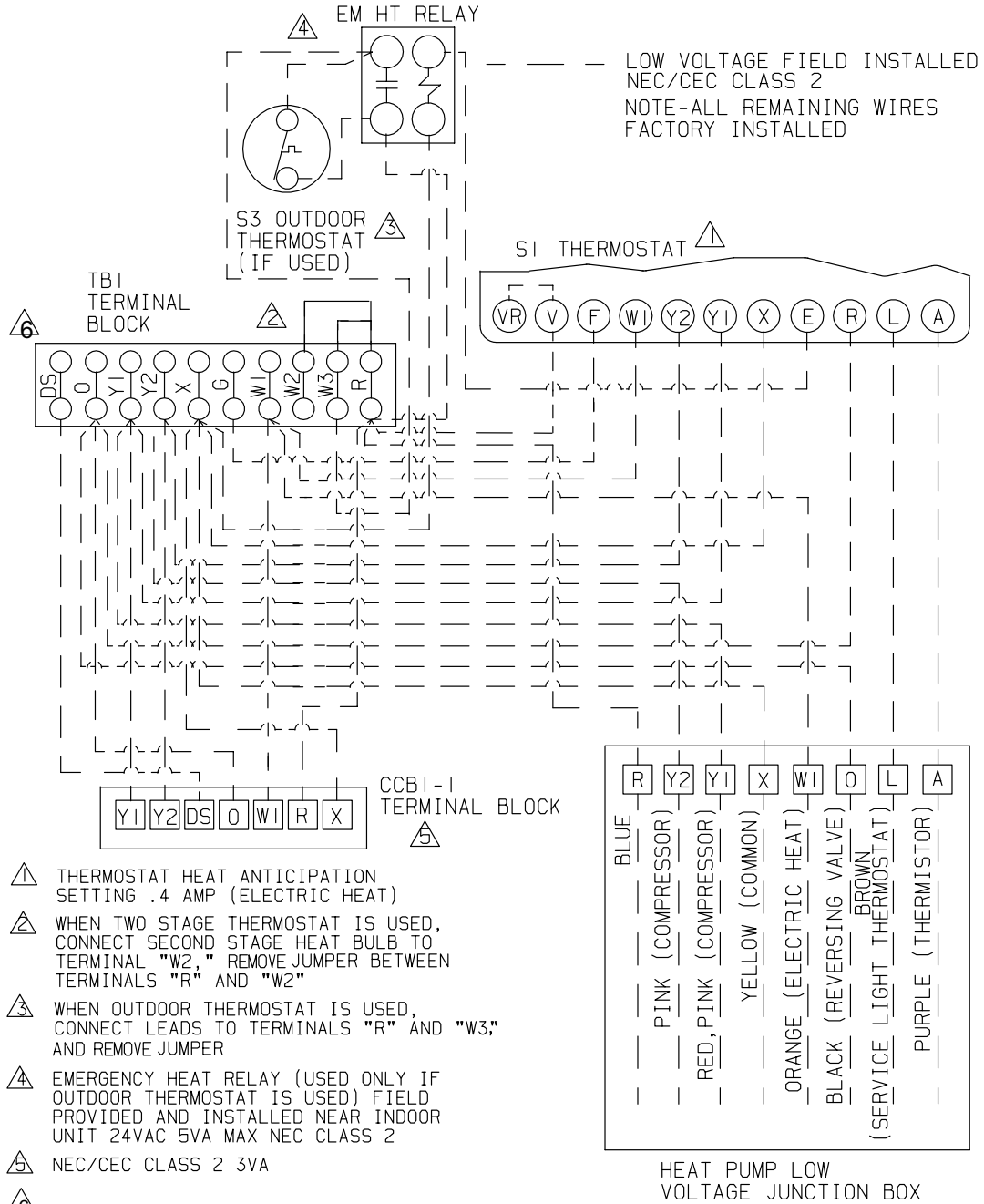

FIGURE 24

HEAT PUMP WITH ELECTRIC HEAT



FIELD INSTALLED JUMPERS REQUIRED FOR TERMINAL STRIP TB1		
Humidity Control	Outdoor Unit	Jumpers Required
With CCB1 Humidity Control	Single-Speed Heat Pump	Y1 to Y2
	Two-Speed Heat Pump	none
Without CCB1 Humidity Control	Single-Speed Heat Pump	DS to Y1
	Two-Speed Heat Pump	DS to Y2

FIGURE 25

FIELD WIRING FOR ECB21 5 KW SINGLE-PHASE HEATERS

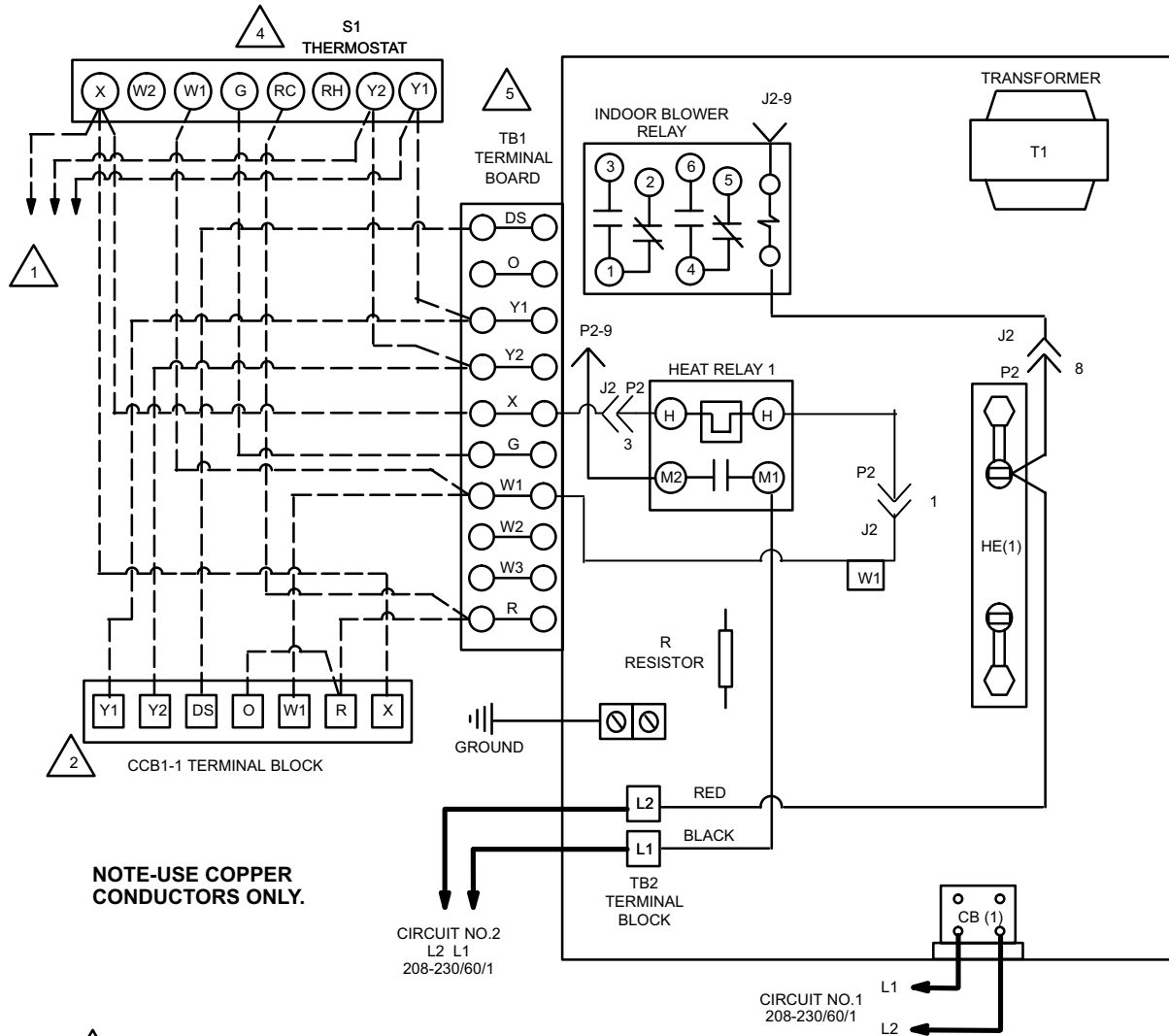

1 TO EXTERNAL LOAD 24VAC AT .50 AMP MAXIMUM.

2 NEC/CEC CLASS 2 3VA

3 SEE FIGURE 25 FOR TYPICAL HEAT PUMP T'STAT WIRING. EMERGENCY HEAT RELAY (USED ONLY IF OUTDOOR THERMOSTAT IS USED) FIELD-PROVIDED AND INSTALLED NEAR INDOOR UNIT. 24VAC 5VA MAXIMUM NEC CLASS 2.

4 THERMOSTAT HEAT ANTICIPATION SETTING .4 AMP (ELECTRIC HEAT)

5 REFER TO JUMPER APPLICATION TABLES IN TYPICAL HEAT PUMP OR COOLING WIRING DIAGRAMS IN THIS MANUAL.

MINIMUM WIRE SIZE	
UNIT	WIRE SIZE
CB21-41/51/65 (CKT #1)	14
ECB21-5.0-1P (CKT #2)	10

— LINE VOLTAGE FIELD INSTALLED
 - - - LOW VOLTAGE FIELD INSTALLED
 NEC/CEC CLASS 2

NOTE-ALL OTHER WIRES FACTORY INSTALLED

FIGURE 26

FIELD WIRING FOR ECB21 6, 7, OR 8 KW SINGLE-PHASE HEATERS

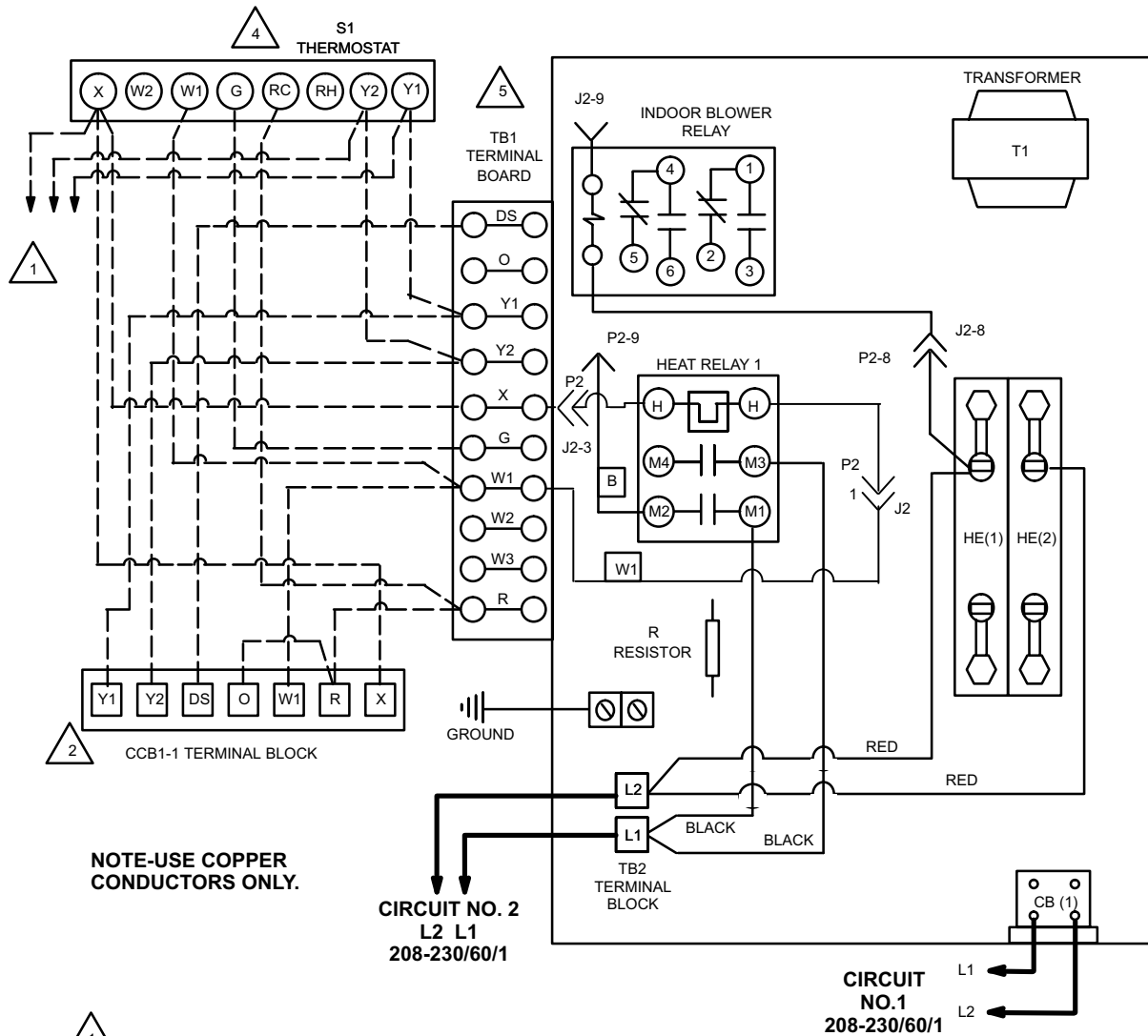

NOTE-USE COPPER CONDUCTORS ONLY.

1 TO EXTERNAL LOAD 24VAC AT .50 AMP MAXIMUM.

2 NEC/CEC CLASS 2 3VA

3 SEE FIGURE 25 FOR TYPICAL HEAT PUMP T'STAT WIRING. EMERGENCY HEAT RELAY (USED ONLY IF OUTDOOR THERMOSTAT IS USED) FIELD-PROVIDED AND IN-STALLED NEAR INDOOR UNIT. 24VAC 5VA MAXIMUM NEC CLASS 2.

4 THERMOSTAT HEAT ANTICIPATION SETTING .4 AMP (ELECTRIC HEAT)

5 REFER TO JUMPER APPLICATION TABLES IN TYPICAL HEAT PUMP OR COOLING WIRING DIAGRAMS IN THIS MANUAL.

MINIMUM WIRE SIZE	
UNIT	WIRE SIZE
CB21-41/51/65 (CKT # 1)	14
ECB21-6.0-1P (CKT # 2)	8
ECB21-7.0-1P (CKT # 2)	8
ECB21-8.0-1P (CKT # 2)	6

— LINE VOLTAGE FIELD INSTALLED
 - - - LOW VOLTAGE FIELD INSTALLED
 NEC/CEC CLASS 2

NOTE-ALL OTHER WIRES FACTORY INSTALLED

FIGURE 27

FIELD WIRING FOR ECB21 10.0 KW SINGLE-PHASE HEATER

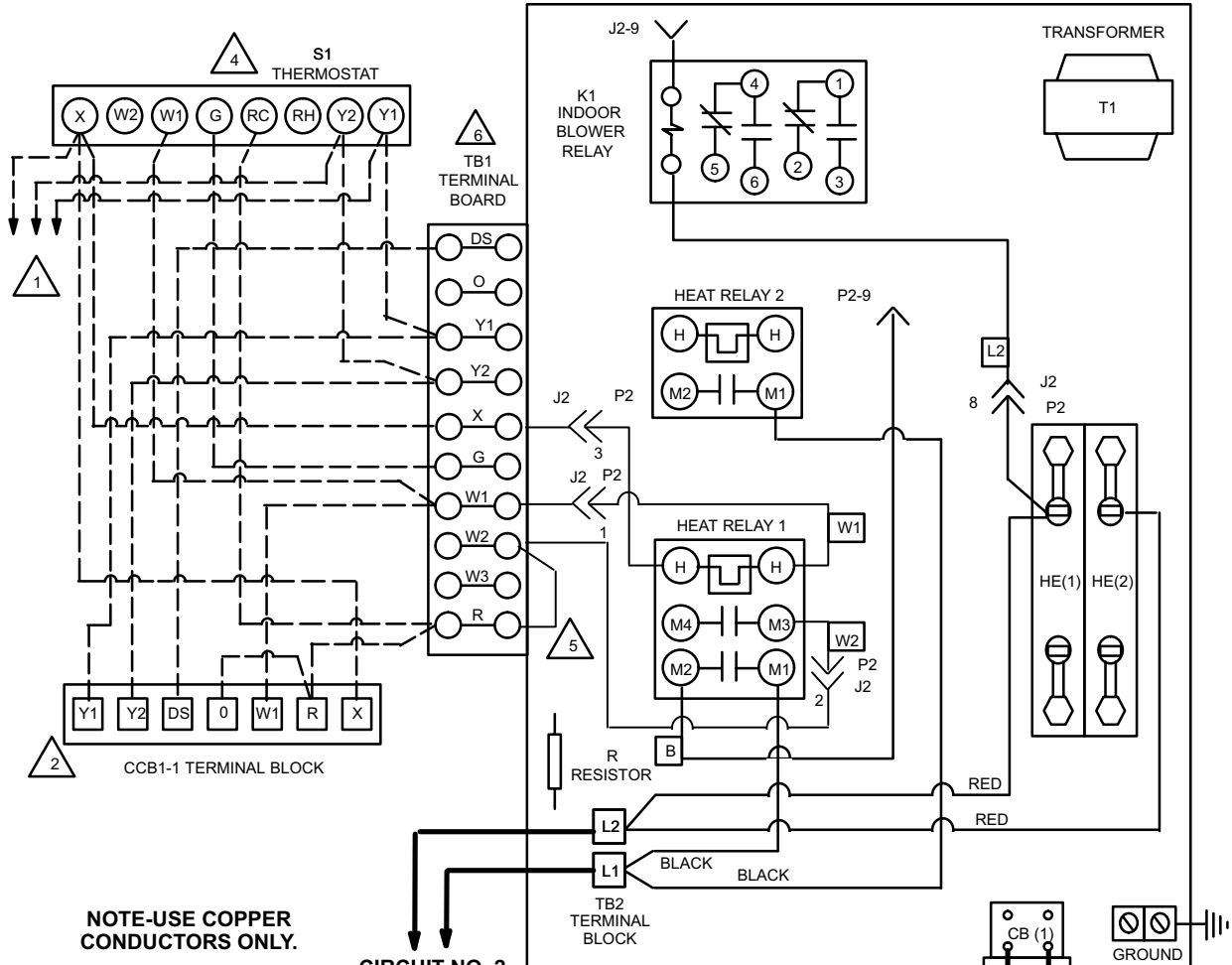

NOTE-USE COPPER CONDUCTORS ONLY.

CIRCUIT NO. 2
L2 L1
208-230/60/1

CIRCUIT NO. 1
L1
208-230/6/0/1

- 1 TO EXTERNAL LOAD 24VAC AT .50 AMP MAXIMUM.
- 2 NEC/CEC CLASS 2
- 3 SEE FIGURE 25 FOR TYPICAL HEAT PUMP T'STAT WIRING. EMERGENCY HEAT RELAY (USED ONLY IF OUTDOOR THERMOSTAT IS USED) FIELD-PROVIDED AND INSTALLED NEAR INDOOR UNIT. 24VAC 5VA MAXIMUM NEC/CEC CLASS 2.
- 4 THERMOSTAT HEAT ANTICIPATION SETTING .4 AMP (ELECTRIC HEAT)
- 5 WHEN TWO-STAGE T'STAT IS USED, CONNECT SECOND-STAGE HEAT BULB TO TERMINAL "W2." REMOVE JUMPER BETWEEN TERMINALS "R" AND "W2."
- 6 REFER TO JUMPER APPLICATION TABLES IN TYPICAL HEAT PUMP OR COOLING WIRING DIAGRAMS IN THIS MANUAL.

MINIMUM WIRE SIZE	
UNIT	WIRE SIZE
CB21-41/51/65 (CKT # 1)	14
ECB21-10.0-1P (CKT # 2)	6

— LINE VOLTAGE
 - - - LOW VOLTAGE
 NEC/CEC CLASS 2

NOTE-ALL OTHER WIRES
 FACTORY INSTALLED

FIGURE 28

FIELD WIRING FOR ECB21 12.5, 15.0 OR 20.0 KW SINGLE-PHASE HEATERS

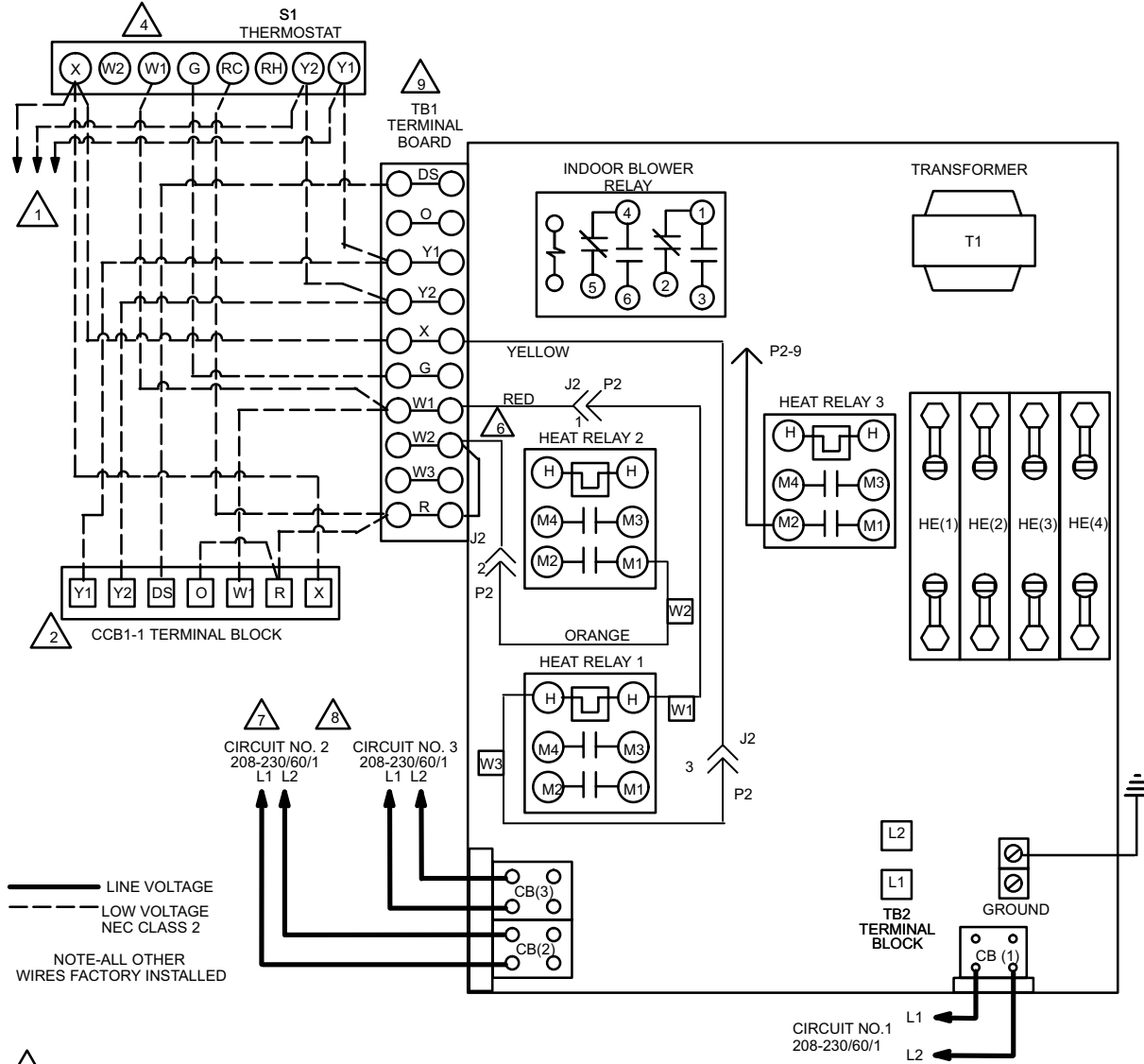

- △ 1 TO EXTERNAL LOAD 24VAC AT .50 AMP MAXIMUM.
- △ 2 NEC/CEC CLASS 2 3VA
- △ 3 SEE FIGURE 25 FOR TYPICAL HEAT PUMP T'STAT WIRING. EMERGENCY HEAT RELAY (USED ONLY IF OUTDOOR THERMOSTAT IS USED) FIELD-PROVIDED AND INSTALLED NEAR INDOOR UNIT. 24VAC 5VA MAXIMUM NEC/CEC CLASS 2.
- △ 4 THERMOSTAT HEAT ANTICIPATION SETTING .4 AMP (ELECTRIC HEAT)
- △ 5 CONNECTIONS AT TERMINALS "E" AND "X" OF THERMOSTAT (S1) ONLY IF EMERGENCY HEAT RELAY IS USED.
- △ 6 WHEN TWO-STAGE T'STAT IS USED, CONNECT SECOND-STAGE HEAT BULB TO TERMINAL "W2." REMOVE JUMPER BETWEEN TERMINALS "R" AND "W2."
- △ 7 REFER TO SINGLE DISCONNECT POWER SOURCE RATING PLATE ON INDOOR UNIT FOR MIN. CIRCUIT AMPACITY, MIN. WIRE SIZES AND MAX. OVERCURRENT PROTECTION.
- △ 8 USE COPPER CONDUCTORS ONLY.

△ 9 REFER TO JUMPER APPLICATION TABLES IN TYPICAL HEAT PUMP OR COOLING WIRING DIAGRAMS IN THIS MANUAL.

MINIMUM WIRE SIZE	
UNIT	WIRE SIZE
CB21-41/51/65 (CKT#1)	14
ECB21-12.5-1P (Ckt.#2)	8 (75 °C)
ECB21-12.5-1P (Ckt.#3)	10 (75 °C)
ECB21-15.0-1P (Ckt.#2)	6 (75 °C)
ECB21-15.0-1P (Ckt.#3)	10 (75 °C)
ECB21-20.0-1P (Ckt.#2)	6 (75 °C)
ECB21-20.0-1P (Ckt.#3)	6 (75 °C)

FIGURE 29

FIELD WIRING FOR ECB21 25 OR 30 KW SINGLE-PHASE HEATERS

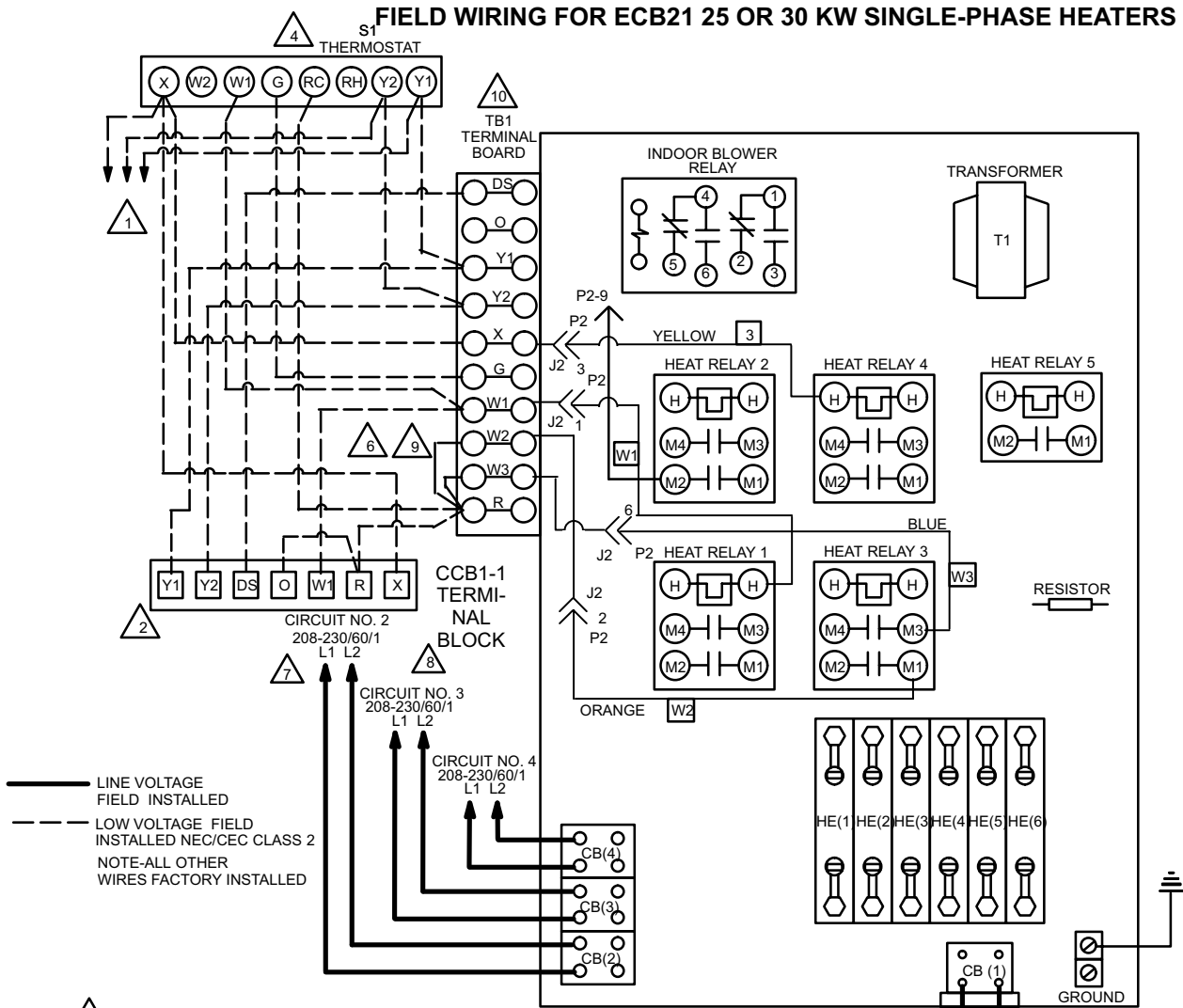

— LINE VOLTAGE FIELD INSTALLED
 - - - LOW VOLTAGE FIELD INSTALLED NEC/CEC CLASS 2
 NOTE-ALL OTHER WIRES FACTORY INSTALLED

1 TO EXTERNAL LOAD 24VAC AT .50 AMP MAXIMUM.

2 NEC/CEC CLASS 2 3VA

3 SEE FIGURE 7 FOR TYPICAL HEAT PUMP T'STAT WIRING. EMERGENCY HEAT RELAY (USED ONLY IF OUTDOOR THERMOSTAT IS USED) FIELD-PROVIDED AND INSTALLED NEAR INDOOR UNIT. 24VAC 5VA MAXIMUM NEC CLASS 2.

4 THERMOSTAT HEAT ANTICIPATION SETTING .4 AMP (ELECTRIC HEAT)

5 CONNECTIONS AT TERMINALS "E" AND "X" OF THERMOSTAT (S1) ONLY IF EMERGENCY HEAT RELAY IS USED.

6 WHEN TWO-STAGE T'STAT IS USED, CONNECT SECOND-STAGE HEAT BULB TO TERMINAL "W2." REMOVE JUMPER BETWEEN TERMINALS "R" AND "W2."

7 REFER TO SINGLE DISCONNECT POWER SOURCE RATING PLATE ON INDOOR UNIT FOR MIN. CIRCUIT AMPACITY, MIN. WIRE SIZES AND MAX. OVERCURRENT PROTECTION.

8 USE COPPER CONDUCTORS ONLY.

9 WHEN OUTDOOR THERMOSTAT IS USED, CONNECT LEADS TO TERMINALS "R" AND "W3" AND REMOVE JUMPER

UNIT	MINIMUM WIRE SIZE		
	CKT.#2	CKT.#3	CKT.#4
ECB21-25.0	6 (75 C)	6 (75 C)	10 (75 C)
ECB21-30.0	6 (75 C)	6 (75 C)	6 (75 C)
CB21-41/51/65 (CKT.#1)	14		

10 REFER TO JUMPER APPLICATION TABLES IN TYPICAL HEAT PUMP OR COOLING WIRING DIAGRAMS IN THIS MANUAL.

FIGURE 30

FIELD WIRING FOR ECB21 5, 7.5, 10 AND 15 Kw THREE-PHASE HEATERS

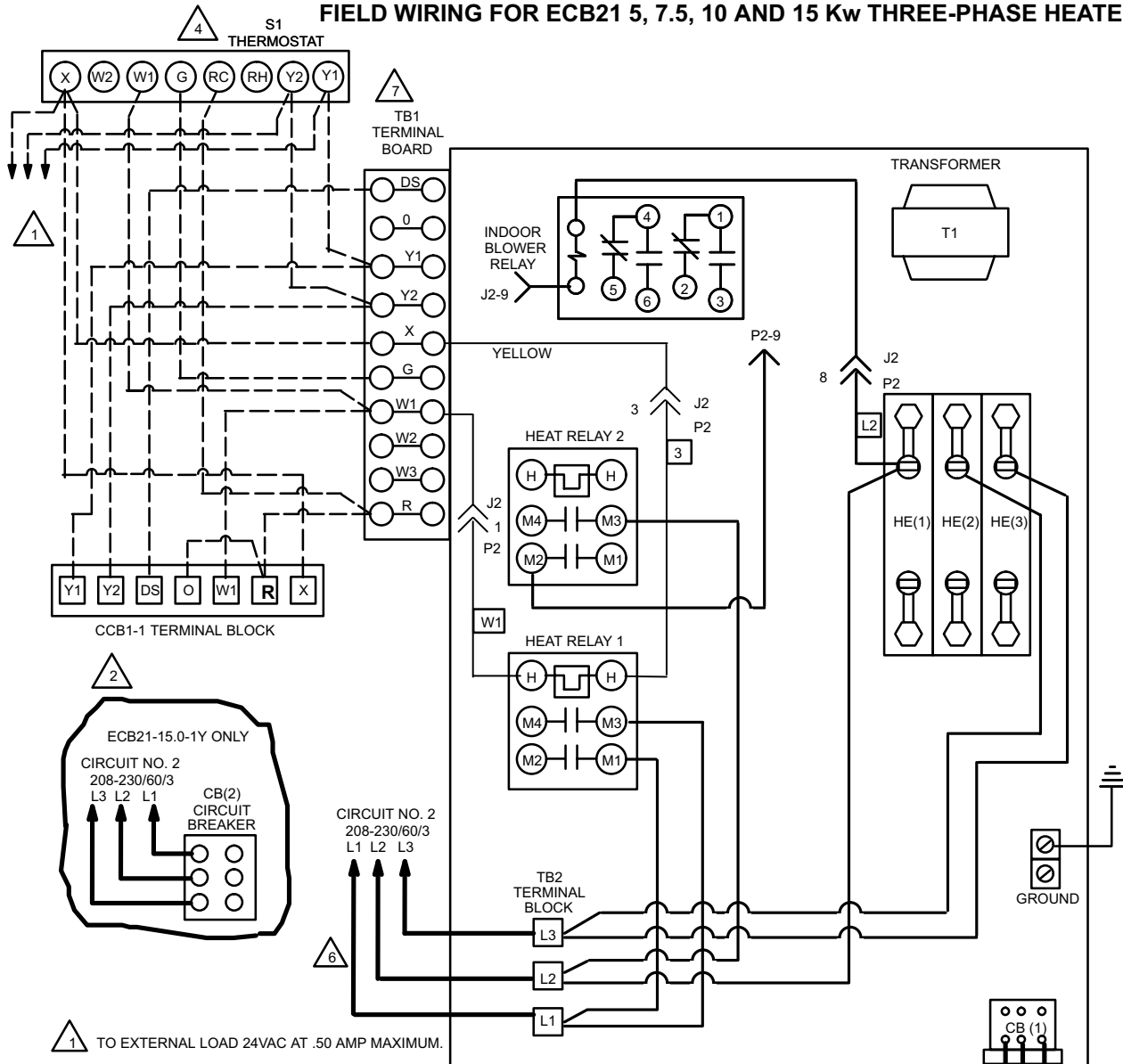

- 1** TO EXTERNAL LOAD 24VAC AT .50 AMP MAXIMUM.
- 2** NEC/CEC CLASS 2 3VA
- 3** SEE FIGURE 25 FOR TYPICAL HEAT PUMP T'STAT WIRING.
EMERGENCY HEAT RELAY (USED ONLY IF OUTDOOR THERMOSTAT IS USED) FIELD-PROVIDED AND INSTALLED NEAR INDOOR UNIT. 24VAC 5VA MAXIMUM
- 4** NEC THERMOSTAT HEAT ANTICIPATION SETTING .4 AMP (ELECTRIC HEAT)
- 5** CONNECTIONS AT TERMINALS "E" AND "X" OF THERMOSTAT (S1) ONLY IF EMERGENCY HEAT RELAY IS USED.
- 6** USE COPPER CONDUCTORS ONLY.

MINIMUM WIRE SIZE	
UNIT	WIRE SIZE
CB21-41/51/65 (CKT #1)	14
ECB21-5.0-1Y (CKT #2)	14
ECB21-7.5-1Y (CKT #2)	12
ECB21-10.0-1Y (CKT #2)	10A (75 C)
ECB21-15.0-1Y (CKT #2)	8 (75 C)

7 REFER TO JUMPER APPLICATION TABLES IN TYPICAL HEAT PUMP OR COOLING WIRING DIAGRAMS IN THIS MANUAL.

LINE VOLTAGE FIELD INSTALLED
 LOW VOLTAGE FIELD INSTALLED
 NEC/CEC CLASS 2
 NOTE-ALL OTHER WIRES FACTORY INSTALLED

FIGURE 31

FIELD WIRING FOR ECB21 20, 25 Kw THREE-PHASE HEATERS

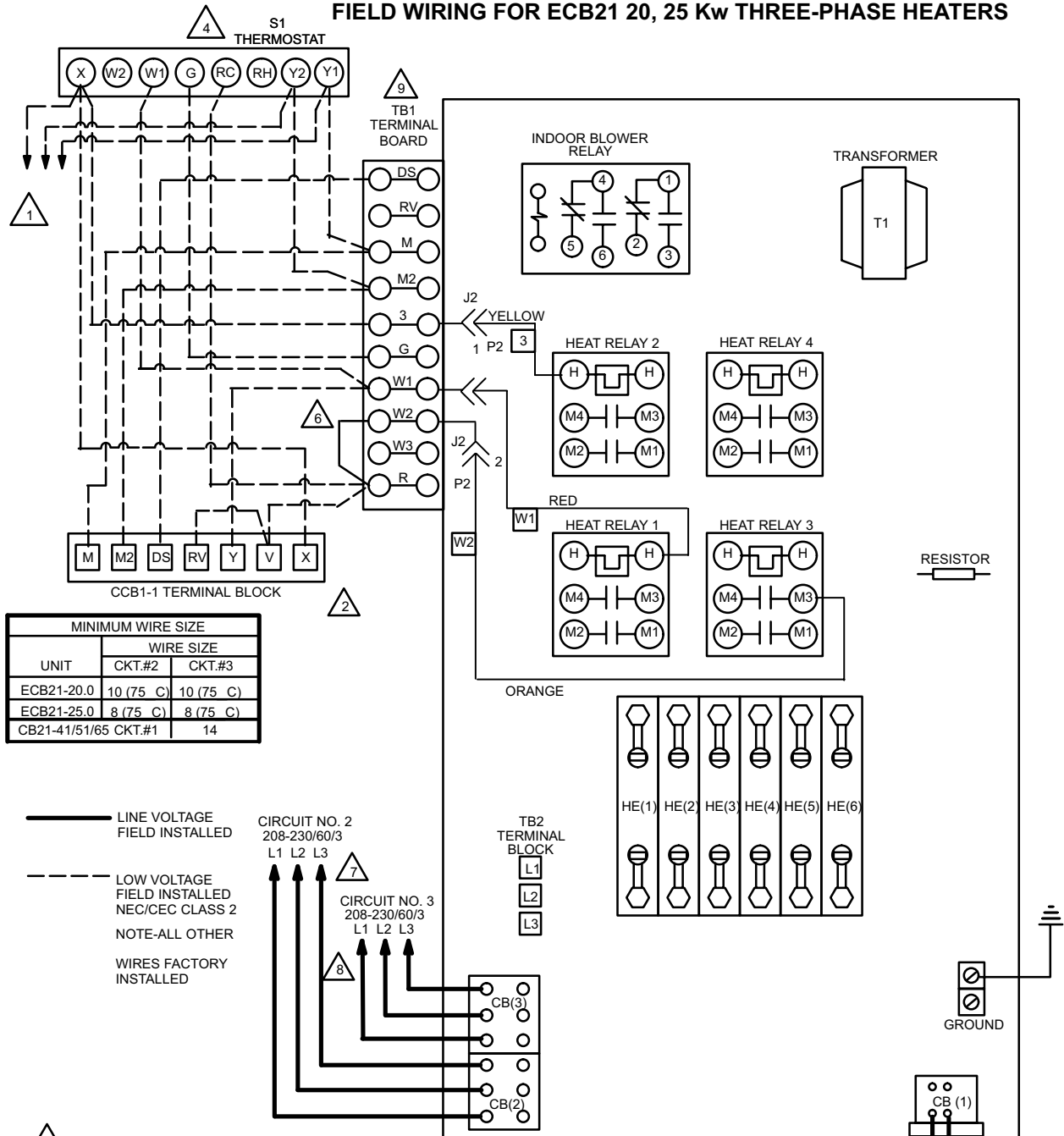

UNIT	WIRE SIZE	
	CKT.#2	CKT.#3
ECB21-20.0	10 (75 C)	10 (75 C)
ECB21-25.0	8 (75 C)	8 (75 C)
CB21-41/51/65 CKT.#1	14	

— LINE VOLTAGE FIELD INSTALLED
 - - - LOW VOLTAGE FIELD INSTALLED
 NEC/CEC CLASS 2
 NOTE-ALL OTHER WIRES FACTORY INSTALLED

- 1 TO EXTERNAL LOAD 24VAC AT .50 AMP MAXIMUM.
- 2 NEC/CEC CLASS 2 3VA.
- 3 SEE FIGURE 25 FOR TYPICAL HEAT PUMP T'STAT WIRING. EMERGENCY HEAT RELAY (USED ONLY IF OUTDOOR THERMOSTAT IS USED) FIELD-PROVIDED AND INSTALLED NEAR INDOOR UNIT. 24VAC 5VA MAXIMUM NEC/CEC CLASS 2.
- 4 THERMOSTAT HEAT ANTICIPATION SETTING .4 AMP (ELECTRIC HEAT).
- 5 CONNECTIONS AT TERMINALS "E" AND "X" OF THERMOSTAT (S1) ONLY IF EMERGENCY HEAT RELAY IS USED.
- 6 WHEN TWO-STAGE T'STAT IS USED, CONNECT SECOND-STAGE HEAT BULB TO TERMINAL "W2." REMOVE JUMPER BETWEEN TERMINALS "R" AND "W2."
- 7 REFER TO SINGLE DISCONNECT POWER SOURCE RATING PLATE ON INDOOR UNIT FOR MIN. CIRCUIT AMPACITY, MIN. WIRE SIZES AND MAX. OVERCURRENT PROTECTION.
- 8 USE COPPER CONDUCTORS ONLY.
- 9 REFER TO JUMPER APPLICATION TABLES IN TYPICAL HEAT PUMP OR COOLING WIRING DIAGRAMS IN THIS MANUAL.

FIGURE 32

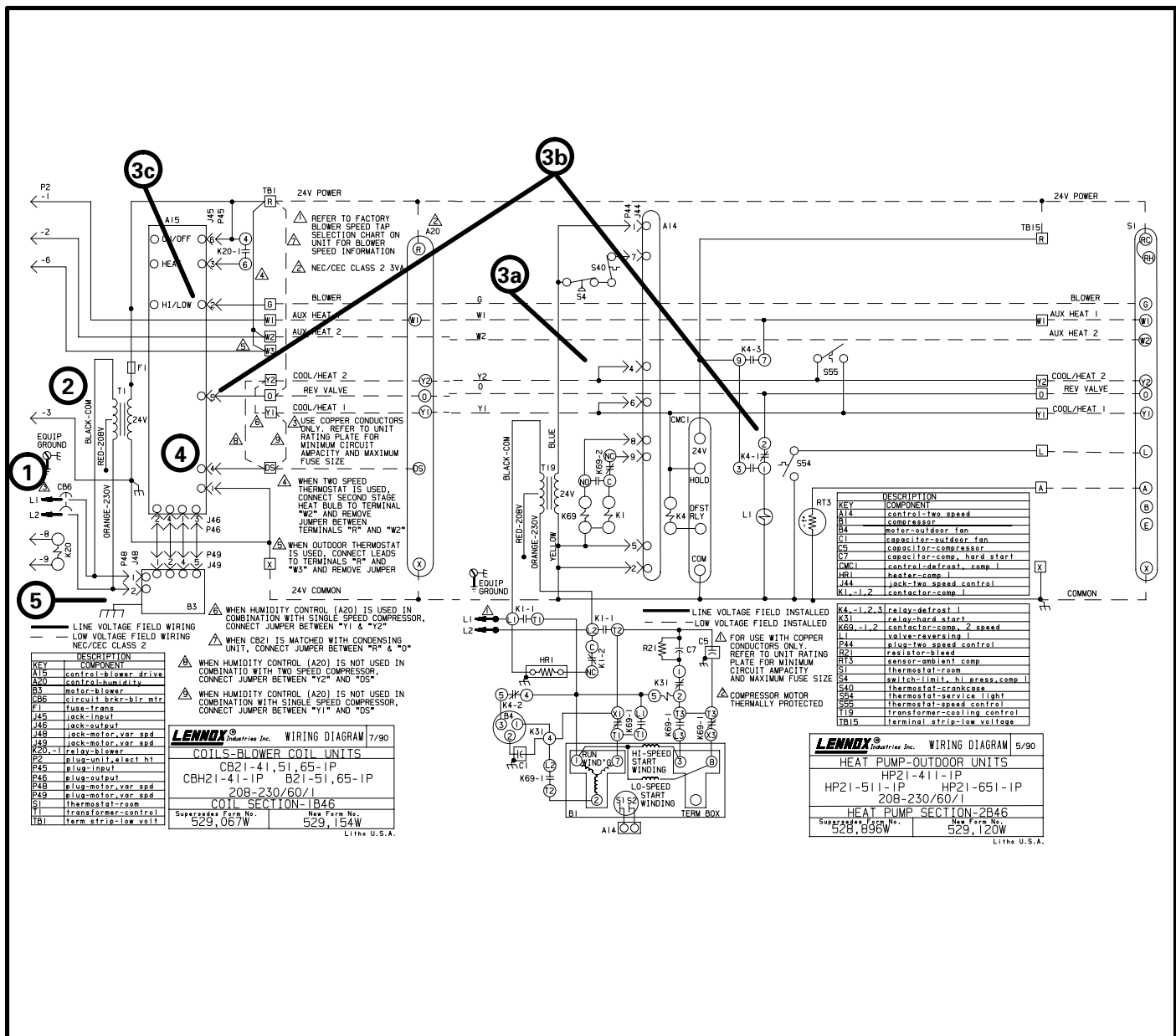

FIGURE 33

B-CB21 OPERATING SEQUENCE

- 1- When disconnect is closed, line voltage is supplied to unit through circuit breaker CB6.
- 2- Transformer T1 supplies 24VAC power to indoor thermostat, indoor unit and outdoor unit controls. Outdoor unit (HP21) controls operated by T1 (indoor unit transformer) include two-speed control, speed control thermostat, contactor coils, defrost control and defrost relay.
- 3- 1st stage demand energizes TB1-Y1, TB1-O and TB1-G:
 - a- TB1-Y1 energizes TSC (J44 pin 6). Speed control thermostat S55 and defrost control terminal HOLD. Defrost control initializes timing sequence. Compressor begins operating after TSC time delay.

- b- TB1-O energizes the reversing valve, CCB1 (A20) terminal O and BDC jack J45 pin 5. J45 pin 5 signals the BDC that the unit is in cooling mode and the blower should operate on one of the two cooling speeds.
- c- TB1-G energizes J45 pin 2. J45 pin 2 signals the BDC (A15) that a cooling demand is present and to begin blower startup.
- 4- If BDC (A15) is receiving voltage signal from CCB1 pin "DS" (A20), blower operates at high speed. If BDC is not receiving voltage from CCB1, blower operates at low speed Refer to section III-F-Blower Drive Control A15 and section III-G-Blower / Motor B3 for more information on the interaction between the blower motor and the BDC.
- 5- Blower motor begins operating at low speed or high speed as determined by the BDC (A15).

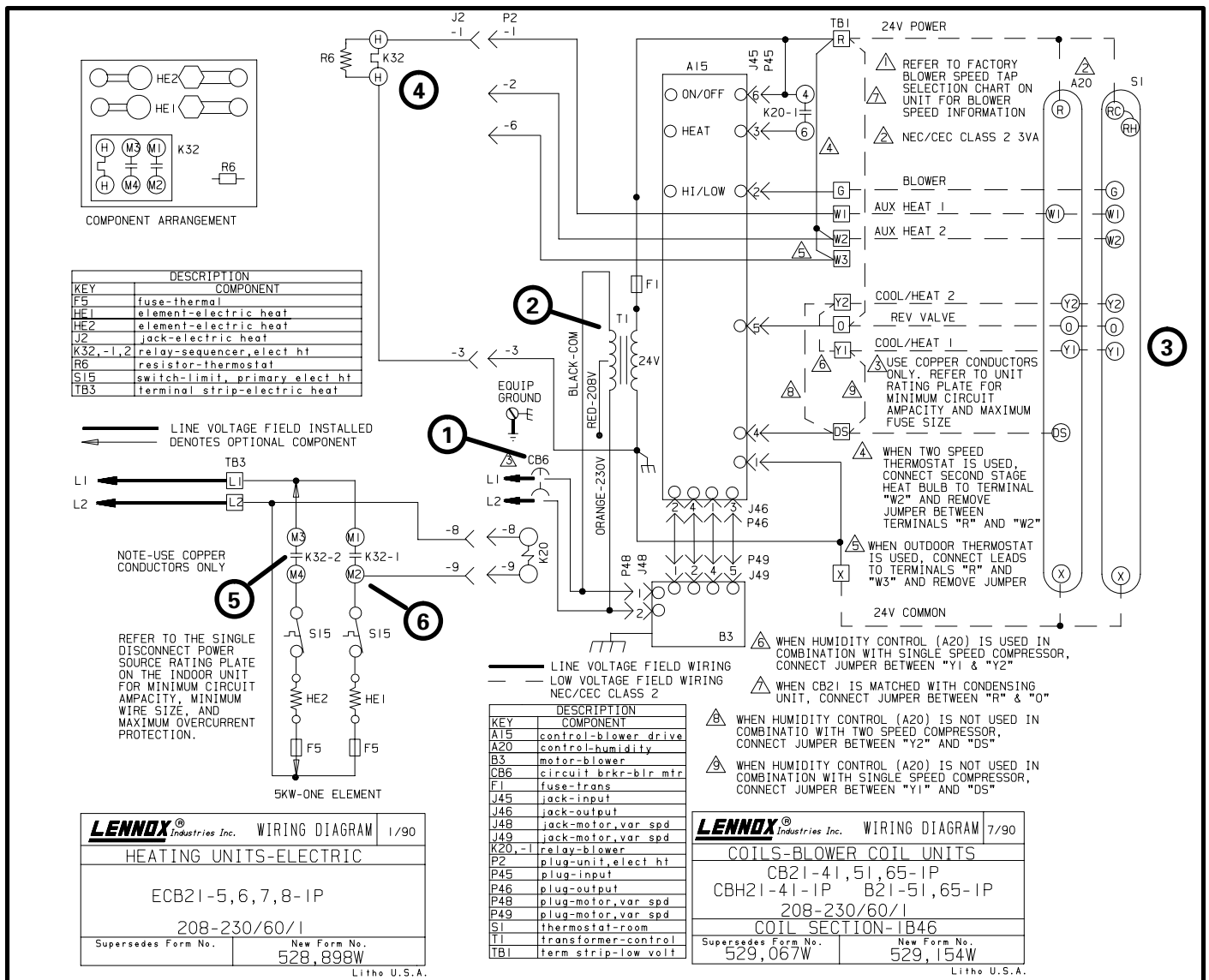

FIGURE 34

C-ECB21-5, -6, -7 and -8 SINGLE PHASE OPERATING SEQUENCE

- 1- When disconnect is closed, line voltage is supplied to blower-coil unit through circuit breaker CB6.
- 2- Transformer T1 supplies 24VAC power to indoor thermostat, indoor unit and outdoor unit controls. Outdoor unit (HP21) controls operated by T1 (indoor unit transformer) include two-speed control, speed control thermostat, contactor coils, defrost control and defrost relay.
- 3- 1st stage heating demand energizes TB1-Y1. TB1-Y1 energizes TSC, speed control thermostat S55 and defrost control terminal HOLD. Defrost control initializes timing sequence. Compressor starts and unit runs in heating mode. Compressor speed is regulated by speed control thermostat in outdoor unit.

NOTE-The lack of a reversing valve output from the indoor thermostat (TB1-O) indicates to the BDC (A15) that the unit is in heating mode. Upon receiving a demand, the BDC signals the blower (B3) to operate on heating speed.

- 4- 2nd stage heating demand energizes TB1-W1 (1st stage bulb continues to run compressor). Heat relay K32 and resistor R6 are energized. Within 1-110 seconds, contacts K32-1 close to energize the heating elements (followed by K32-2 if so equipped),
- 5- When K32-1 closes, relay K20 and heating element HE1 are energized. K20-1 closes to send a heating demand to BDC (A15) jack J45 pin 3. Blower begins operating on heating speed. When K32-2 closes, heating element HE2 is energized.
- 6- When heating demand stops, heat relay K32 cycles off on a last-on first-off basis.
- 7- When there is a call for emergency heat, the compressor is locked-out and the electric heating elements handle all heating demand. Operation sequence does not change.

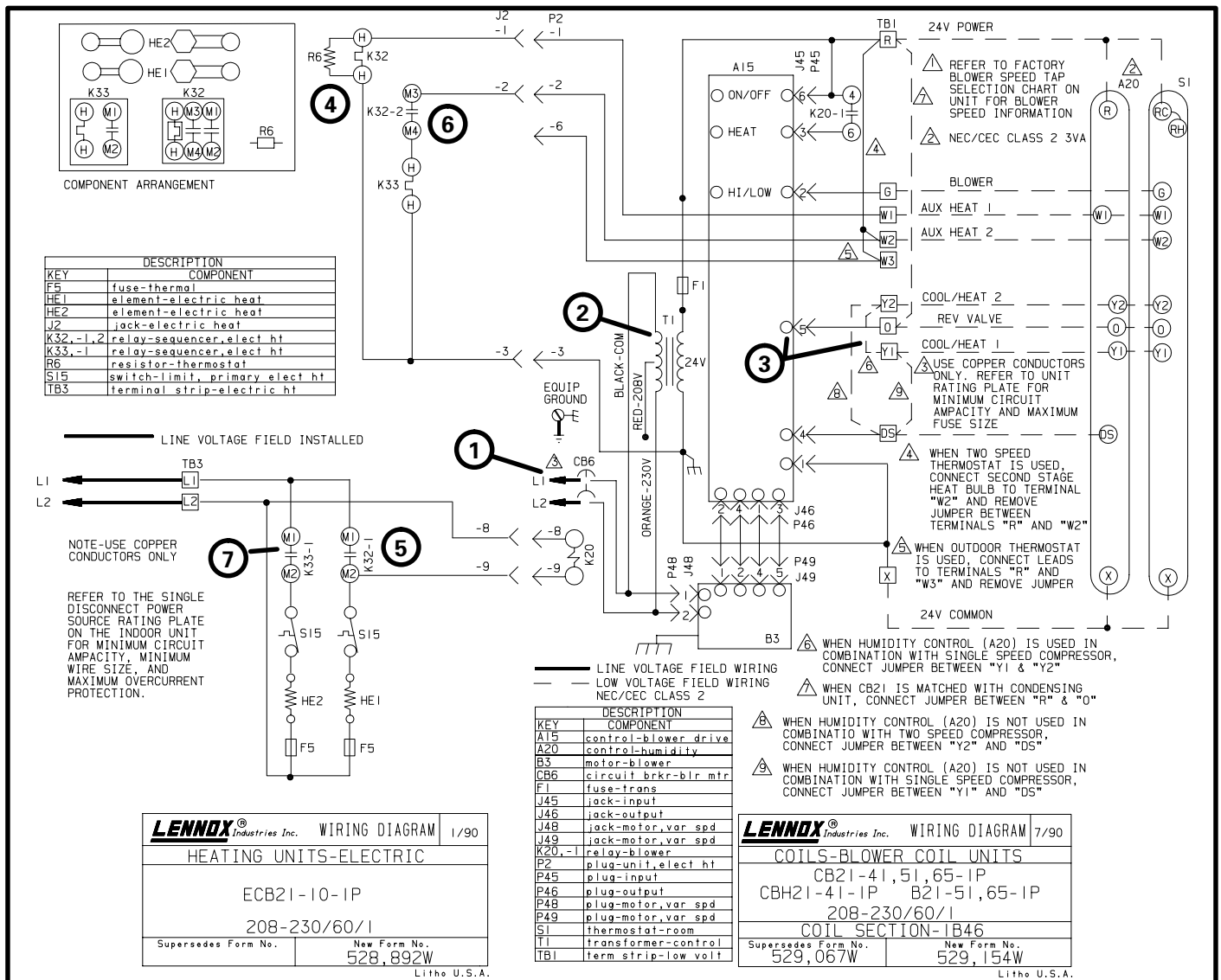

FIGURE 35

D-ECB21-10 SINGLE PHASE OPERATING SEQUENCE

- 1- When disconnect is closed, line voltage is supplied to blower-coil unit through circuit breaker CB6.
- 2- Transformer T1 supplies 24VAC power to indoor thermostat, indoor unit and outdoor unit controls. Outdoor unit (HP21) controls operated by T1 (indoor unit transformer) include two-speed control, speed control thermostat, contactor coils, defrost control and defrost relay.
- 3- 1st stage heating demand energizes TB1-Y1. TB1-Y1 energizes TSC, speed control thermostat S55 and defrost control terminal HOLD. Defrost control initializes timing sequence. Compressor start and unit runs in heating mode. Compressor speed is regulated by speed control thermostat in outdoor unit.

NOTE-The lack of a reversing valve output from the indoor thermostat (TB1-O) indicates to the BDC (A15) that the unit is in heating mode. Upon receiving a demand, the BDC signals the blower (B3) to operate on heating speed.

- 4- 2nd stage heating demand energizes TB1-W1 (1st stage bulb continues to run compressor). Heat relay K32 and resistor R6 are energized. Within 1-110 seconds, contacts K32-1 close to energize the heating elements (followed by K32-2 if so equipped),
- 5- When K32-1 closes, relay K20 and 1st stage heating element (HE1) are energized. K20-1 closes to send a heating demand to BDC (A15) jack J45 pin 3. Blower begins operating on heating speed.
- 6- When K32-2 closes, heat relay K33 is energized. Within 1-110 sec. K33-1 closes to energize heating element HE2.
- 7- When heating demand stops, heat relays K32 and K33 cycle off on a last-on first-off basis.
- 8- When there is a call for emergency heat, the compressor is locked-out and the electric heating elements handle all heating demand. Operation sequence does not change.

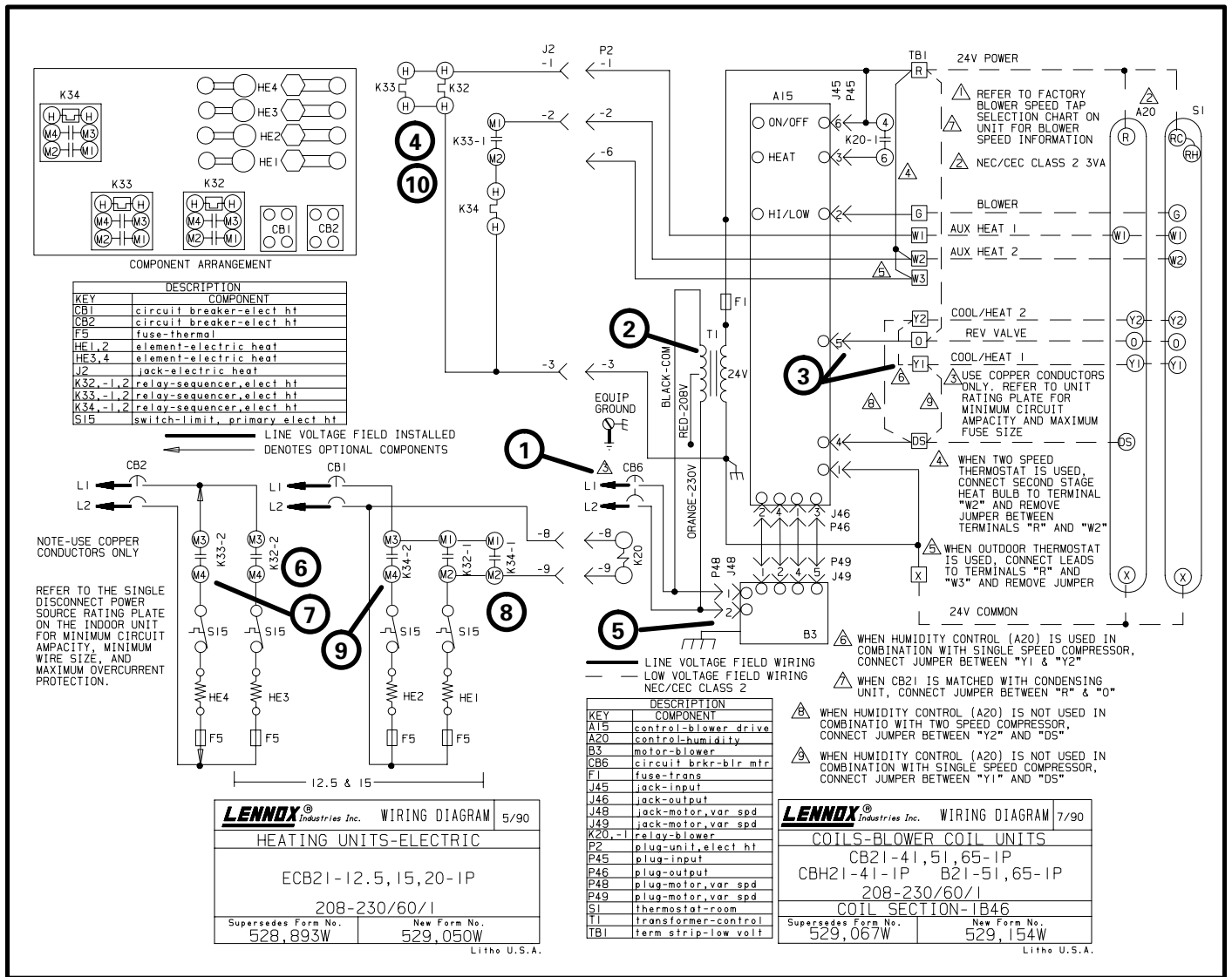

FIGURE 36

E-ECB21-12.5, -15, -20 SINGLE PHASE OPERATING SEQUENCE

- When disconnect is closed, line voltage is supplied to blower-coil unit through circuit breaker CB6.
- Transformer T1 supplies 24VAC power to indoor thermostat, indoor unit and outdoor unit controls. Outdoor unit (HP21) controls operated by T1 (indoor unit transformer) include two-speed control, speed control thermostat, contactor coils, defrost control and defrost relay.
- 1st stage heating demand energizes TB1-Y1. TB1-Y1 energizes TSC, speed control thermostat S55 and defrost control terminal HOLD. Defrost control initializes timing sequence. Compressor start and unit runs in heating mode. Compressor speed is regulated by speed control thermostat in outdoor unit.

NOTE-The lack of a reversing valve output from the indoor thermostat (TB1-O) indicates to the BDC (A15) that the unit is in heating mode. Upon receiving a demand, the BDC signals the blower (B3) to operate on heating speed.

- 2nd stage heating demand energizes TB1-W1 (1st stage bulb continues to run compressor). Heat relays K32 and K33 are energized. Within 1-110 seconds, contacts K32-1 and K33-1 close to energize the heating elements.
- When K32-1 closes, 1st stage heating element (HE1) and blower relay K20 are energized. When K34-1 closes, blower relay (K20) is latched-in. K20-1 closes to send a heating demand to BDC (A15) jack J45 pin 3. Blower begins operating on heating speed.
- When K32-2 closes, heating element HE3 is energized.
- When K33-2 closes, heat relay K34 is energized. Within 1-110 seconds, contacts K34-1 close to energize 2nd stage heating elements followed by K34-2.
- When K34-1 closes, heating element HE1 is energized (redundant).
- When K34-2 closes, heating element HE4 is energized.
- When heating demand stops, heat relays K32, K33 and K34 cycle off on a last-on first-off basis.
- When there is a call for emergency heat, the compressor is locked-out and the electric heating elements handle all heating demand. Operation sequence does not change.