

## CB21V WITH ICM2+ MOTOR SERIES UNITS INCLUDING CBH21V, CH21V, and B21V

This supplement is to be used with CB21 Unit Information Manual (Corp. 9020-L8). All CB21V series units use TXV expansion valves. The CB21V units feature direct drive multi-speed blower motors. The integrated control motor (ICM2+) is controlled by an electronic blower drive control (BDC2). The supplement will give only information pertaining to the integrated control motor (ICM2+) and the electronic blower drive control (BDC2).

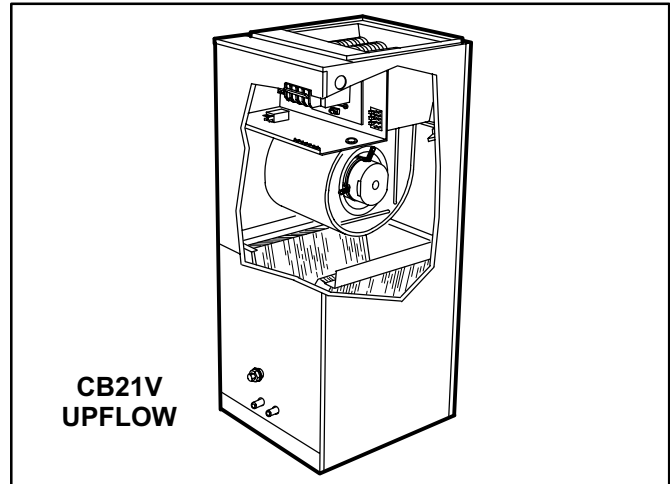

### I-Blower Motors

CB21V units use a three-phase, electronically controlled d.c. brushless motor (controller converts single phase a.c. to three phase d.c.), with a permanent-magnet-type rotor (figure 1). Because this motor has a permanent magnet rotor it does not need brushes like conventional D.C. motors. Internal components are shown in figure 1. The stator windings are split into three poles which are electrically connected to the controller. This arrangement allows motor windings to be turned on and off in sequence by the controller.

A solid-state controller is permanently attached to the motor. The controller is primarily an a.c. to d.c. converter. Converted d.c. power is used to drive the motor. The controller contains a microprocessor which monitors varying conditions inside motor (such as motor workload).

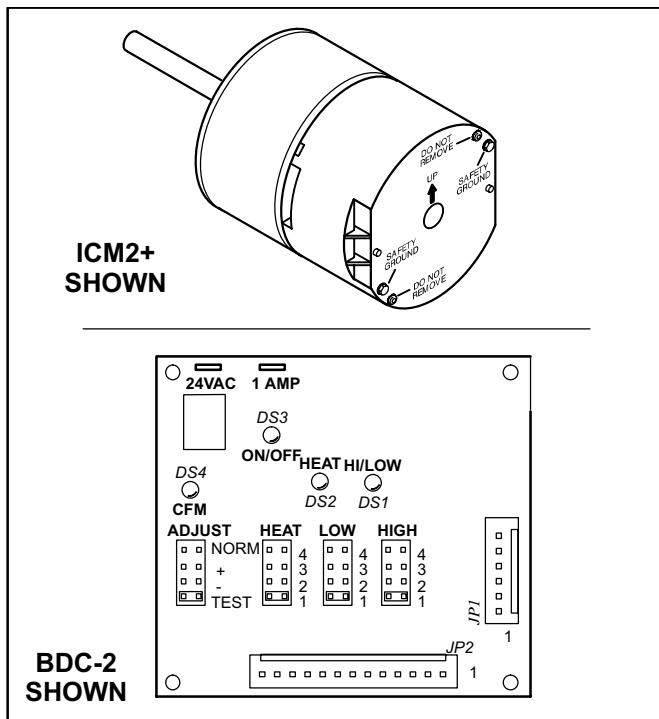

### SPECIFICATIONS

Model No.	CB21V-41	CBH21V-41	CB21V-51	CBH21V-51	CB21V-65	CBH21V-65	
Blower Section	----	----	----	B21V-51/65	----	B21V-51/65	
Indoor Coil Section	----	----	----	CH21-51	----	CH19-65	
Indoor Coil	Net face area - ft. <sup>2</sup> (m <sup>2</sup> )	5.27 (0.49)	5.27 (0.49)	7.0 (0.65)	7.22 (0.67)	7.0 (0.65)	7.22 (0.67)
	Tube diameter - in. (mm)	3/8 (9.5)	3/8 (9.5)	3/8 (9.5)	3/8 (9.5)	3/8 (9.5)	3/8 (9.5)
	Fins per inch (fins per m)	13 (512)	13 (512)	14 (551)	14 (551)	14 (551)	14 (551)
	Vapor line connection - in.(mm)-sweat	3/4 (19)	3/4 (19)	7/8 (22.2)	7/8 (22.2)	1-1/8 (28)	1-1/8 (28)
	Liquid line connection - in.(mm)-sweat	3/8 (9.5)	3/8 (9.5)	3/8 (9.5)	3/8 (9.5)	3/8 (9.5)	3/8 (9.5)
Condensate drain - in. (mm)	(2) 3/4 (19)	(2) 3/4 (19)	(2) 3/4 (19)	(2) 3/4 (19)	(2) 3/4 (19)	(2) 3/4 (19)	
Nominal cooling capacity - tons (kW)	3 (10.6)		4 (14.1)		5 (17.6)		
Refrigerant	HCFC-22		HCFC-22		HCFC-22		
Blower wheel nominal diameter x width - in. (mm)	10 x 9 (254 x 229)		12 x 9 (317 x 229)		12 x 9 (317 x 229)		
Blower motor - hp (W)	1/2 (373)		1 (746)		1 (746)		
Electrical characteristics	208/230 volt - 60 hertz - 1 phase						

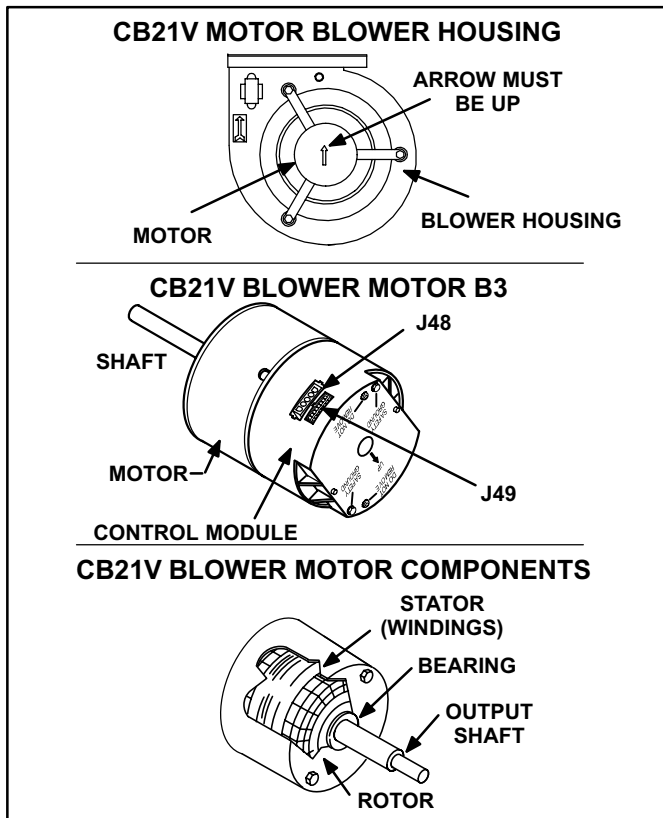

FIGURE 1

## ▲ IMPORTANT

In all applications make sure embossed arrow on the motor is pointing up (perpendicular to the blower housing opening). This assures that condensation will run out, should there be any.

The controller uses sensing devices to know what position the rotor is in at any given time. By sensing the position of the rotor and switching the motor windings on and off in sequence, the rotor shaft turns the blower. CB21V series blower motor ratings are listed in the unit specifications on page 1. All CB21V blower motors use single phase power. An external run capacitor is not used. The motor uses permanently lubricated ball-type bearings.

### A-Internal Operation

Each time the controller switches a stator winding (figure 1) on and off, it is called a “pulse.” The length of time each pulse stays on is called the “pulse width.” By varying the pulse width (figure 2), the controller varies motor speed (called “pulse-width modulation”). This allows for precise control of motor speed and allows the motor to compensate for varying load conditions as sensed by the controller. In this case, the controller monitors the static workload on the motor and varies motor rpm in order to maintain constant airflow (cfm).

The motor is equipped with twelve incremental taps which are driven by the integral controller. The controller is capable of controlling three of the twelve taps.

The motor controller is driven by the BDC-2. The BDC-2 receives its demand (PWM signal or fixed 24 VAC or VDC signal) from optional controls such as the Harmony zone control system, Efficiency Plus Humidity Control (CCB1) or a conventional thermostat.

Motor rpm is continually adjusted internally to maintain constant static pressure against the blower wheel. The controller monitors the static work load on the motor and motor amp-draw to determine the amount of rpm adjustment. Blower rpm may be adjusted any amount in order to maintain a constant cfm as shown in Blower Ratings Tables. Tables 1 through 6 shows the ICM-2 motor watts at various external static pressures and adjustment taps. The amount of adjustment is determined by the incremental taps which are used and the amount of motor loading sensed internally. Since the blower constantly adjusts rpm to maintain a specified cfm, motor rpm is not rated. Hence, the terms “blower speed” and “speed tap” in this manual, on the unit wiring diagram and on blower B3 refer to blower cfm regardless of motor rpm.

When Harmony is used, speed taps are overridden and a PWM signal generated by the Harmony controller continuously varies motor speed based upon zone demand.

### B-Initial Power Up

When line voltage is applied to B3, there will be a large inrush of power lasting less than 1/4 second. This inrush charges a bank of DC filter capacitors inside the controller. If the disconnect switch is bounced when the disconnect is closed, the disconnect contacts may become welded. Try not to bounce the disconnect switch when applying power to the unit.

The DC filter capacitors inside the controller are connected electrically to the speed tap wires. The capacitors take approximately 5 minutes to discharge when the disconnect is opened. For this reason it is necessary to wait at least 5 minutes after turning off power to the unit before attempting to change speed taps.

### C-Motor Start-Up

When B3 begins start-up, the motor gently vibrates back and forth for a moment. This is normal. During this time the electronic controller is determining the exact position of the rotor. Once the motor begins turning, the controller slowly eases the motor up to speed (this is called “soft-start”). The motor may take as long as 10-15 seconds to reach full speed. If the motor does not reach 200rpm within 13 seconds, the motor shuts down. Then the motor will immediately attempt a restart. The shutdown feature provides protection in case of a frozen bearing or blocked blower wheel. The motor may attempt to start eight times. If the motor does not start after the eighth try, the controller locks out. Reset controller by momentarily turning off power to unit.

**TABLE 1  
CB21V-41-2P AND CBH21V-41-2P BLOWER MOTOR WATTS**

Motor Speed Tap	Motor Watts @ Various External Static Pressure (in. wg.) With Adjust Tap = "Norm"								
	0.0	0.1	0.2	0.3	0.4	0.5	0.6	0.7	0.8
High Cool Tap 1	110	135	160	180	200	220	240	260	280
High Cool Tap 2	140	165	185	210	235	260	280	300	320
High Cool Tap 3	220	240	270	295	330	355	385	415	440
High Cool Tap 4	265	295	325	360	390	425	450	475	500
Low Cool Tap 1	60	75	95	110	120	135	150	170	190
Low Cool Tap 2	70	90	110	130	145	160	180	195	220
Low Cool Tap 3	90	110	130	150	170	185	210	230	255
Low Cool Tap 4	110	135	160	180	200	220	240	260	280
Heat Tap 1	140	165	185	210	235	260	280	300	320
Heat Tap 2	195	225	245	270	295	325	345	375	395
Heat Tap 3	220	240	270	295	330	355	385	415	440
Heat Tap 4	265	295	325	360	390	425	450	475	500

**TABLE 2  
CB21V-41-2P AND CBH21V-41-2P BLOWER MOTOR WATTS**

Motor Speed Tap	Motor Watts @ Various External Static Pressure (in. wg.) With Adjust Tap = " + "								
	0.0	0.1	0.2	0.3	0.4	0.5	0.6	0.7	0.8
High Cool Tap 1	145	175	195	220	245	270	295	320	330
High Cool Tap 2	185	210	235	260	285	310	340	360	390
High Cool Tap 3	290	325	365	395	430	460	485	510	540
High Cool Tap 4	360	400	445	480	510	545	575	605	610
Low Cool Tap 1	70	90	110	125	145	165	185	200	220
Low Cool Tap 2	85	110	130	155	175	195	210	235	255
Low Cool Tap 3	120	140	165	190	210	230	250	275	290
Low Cool Tap 4	145	170	195	220	240	265	290	310	325
Heat Tap 1	185	210	230	255	280	305	330	355	385
Heat Tap 2	220	245	280	305	335	365	395	420	450
Heat Tap 3	295	320	360	395	430	455	485	510	540
Heat Tap 4	360	400	445	480	510	545	575	605	610

**TABLE 3  
CB21V-41-2P AND CBH21V-41-2P BLOWER MOTOR WATTS**

Motor Speed Tap	Motor Watts @ Various External Static Pressure (in. wg.) With Adjust Tap = " - "								
	0.0	0.1	0.2	0.3	0.4	0.5	0.6	0.7	0.8
High Cool Tap 1	85	100	120	140	160	180	200	220	240
High Cool Tap 2	105	125	145	170	190	210	230	250	270
High Cool Tap 3	160	190	215	240	260	285	305	325	350
High Cool Tap 4	195	220	245	265	290	315	345	370	395
Low Cool Tap 1	40	55	75	90	105	120	135	150	160
Low Cool Tap 2	50	70	85	100	115	135	145	160	180
Low Cool Tap 3	65	85	105	120	140	155	170	190	210
Low Cool Tap 4	85	100	120	140	160	175	195	215	235
Heat Tap 1	105	125	145	170	190	210	230	250	270
Heat Tap 2	120	150	175	195	220	245	270	285	305
Heat Tap 3	160	190	215	240	260	285	305	325	350
Heat Tap 4	195	220	245	265	290	315	245	370	395

**TABLE 4**  
**CB21V-51/65-2P AND CBH21V-51/65-2P BLOWER MOTOR WATTS**

Motor Speed Tap	Motor Watts @ Various External Static Pressure (in. wg.) With Adjust Tap = "Norm"								
	0.0	0.1	0.2	0.3	0.4	0.5	0.6	0.7	0.8
High Cool Tap 1	180	205	250	290	320	340	385	410	435
High Cool Tap 2	240	275	330	350	385	415	455	475	500
High Cool Tap 3	315	350	385	420	455	515	535	570	635
High Cool Tap 4	390	435	480	530	575	625	670	720	770
Low Cool Tap 1	55	75	95	115	135	150	175	195	210
Low Cool Tap 2	70	85	115	130	150	185	190	215	240
Low Cool Tap 3	95	125	160	170	200	220	245	260	290
Low Cool Tap 4	125	155	190	210	245	275	295	315	350
Heat Tap 1	185	225	255	285	325	355	385	420	440
Heat Tap 2	240	285	320	350	390	425	460	485	510
Heat Tap 3	320	360	400	435	475	520	555	585	625
Heat Tap 4	390	435	480	520	580	605	660	710	755

**TABLE 5**  
**CB21V-51/65-2P AND CBH21V-51/65-2P BLOWER MOTOR WATTS**



Motor Speed Tap	Motor Watts @ Various External Static Pressure (in. wg.) With Adjust Tap = " + "								
	0.0	0.1	0.2	0.3	0.4	0.5	0.6	0.7	0.8
High Cool Tap 1	235	270	310	345	390	415	455	470	505
High Cool Tap 2	310	350	385	425	435	505	535	585	620
High Cool Tap 3	385	430	485	520	590	615	660	700	765
High Cool Tap 4	510	560	645	670	710	795	820	880	940
Low Cool Tap 1	65	80	105	125	150	165	190	210	230
Low Cool Tap 2	85	110	130	155	175	195	220	235	255
Low Cool Tap 3	125	145	175	200	235	260	280	310	340
Low Cool Tap 4	160	185	225	260	290	325	345	385	415
Heat Tap 1	235	270	325	365	395	415	460	485	510
Heat Tap 2	310	345	400	425	470	515	545	570	620
Heat Tap 3	405	445	490	550	600	630	655	750	780
Heat Tap 4	525	580	625	700	740	780	855	905	935

**TABLE 6**  
**CB21V-51/65-2P AND CBH21V-51/65-2P BLOWER MOTOR WATTS**

Motor Speed Tap	Motor Watts @ Various External Static Pressure (in. wg.) With Adjust Tap = " - "								
	0.0	0.1	0.2	0.3	0.4	0.5	0.6	0.7	0.8
High Cool Tap 1	100	125	140	160	175	190	220	245	275
High Cool Tap 2	130	160	180	225	250	270	310	340	365
High Cool Tap 3	205	240	270	315	345	375	420	445	475
High Cool Tap 4	285	325	370	395	425	465	520	440	590
Low Cool Tap 1	45	60	80	100	115	135	155	175	185
Low Cool Tap 2	55	70	85	115	130	150	170	195	205
Low Cool Tap 3	75	100	120	145	165	185	200	225	340
Low Cool Tap 4	95	120	155	175	200	220	240	255	285
Heat Tap 1	140	170	200	225	265	290	315	340	375
Heat Tap 2	180	210	250	275	325	345	380	410	440
Heat Tap 3	230	275	310	350	385	415	460	480	510
Heat Tap 4	285	340	375	410	430	485	520	555	595

## MOTOR SPEED CONTROL WITH D.C. PULSE-WIDTH MODULATION

*Motor speed is determined by the size of the electrical pulse sent to the motor windings. The longer the pulse, the faster the motor.*

OUTPUT FROM CONTROLLER TO MOTOR WINDINGS	
WINDINGS TURNED OFF	WINDINGS TURNED ON
	 ON PULSE  OFF PULSE

The frequency of the pulses to the windings is 20KHz.  
DO NOT ATTEMPT TO MEASURE THESE VOLTAGES.

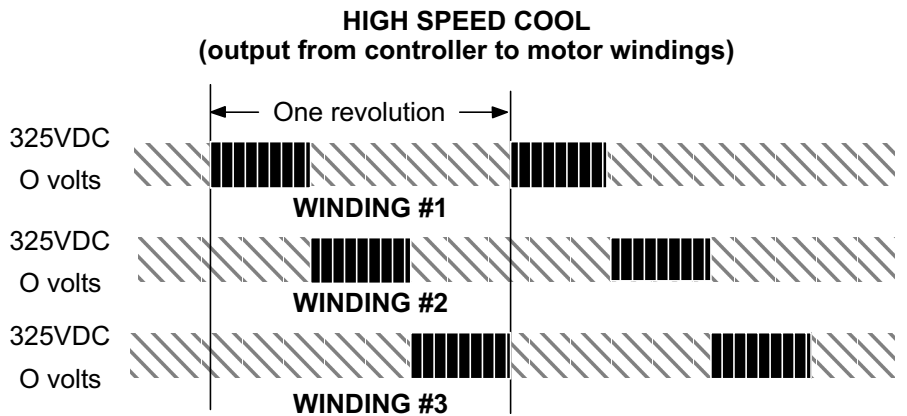
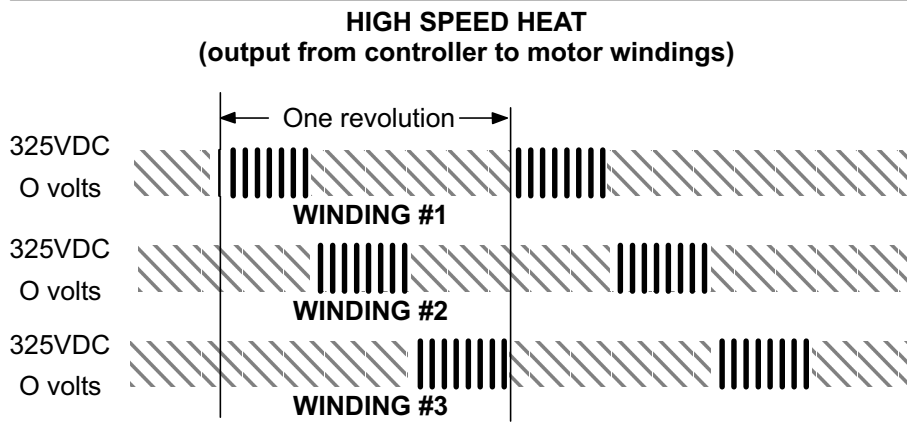
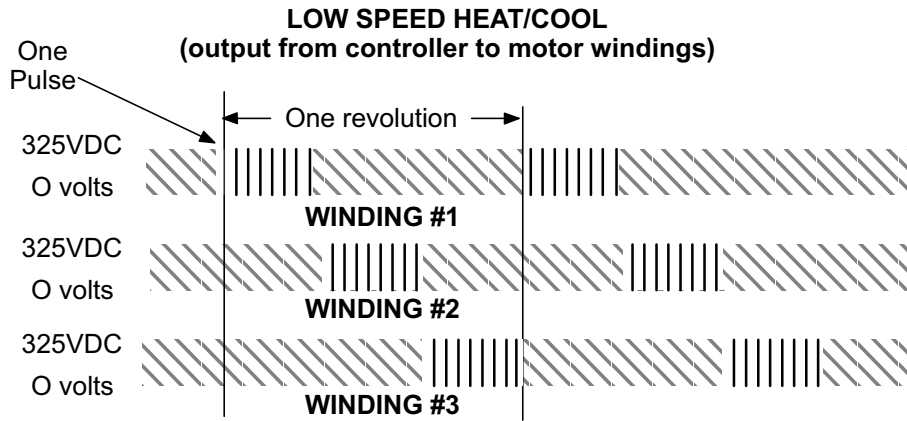

FIGURE 2

## D-External Operation (Speed Tap Priority)

Figure 3 shows the two quick-connect jacks (J48 and J49) which connect the motor to the CB21V. Jack J48 is the power plug and jack J49 connects the unit controls to the motor.

Line voltage must be applied to J48 pin 5 in order for the motor to operate. When control voltage is applied to J49 pin 3 and 15 (single stage heating and cooling), the motor is energized on the low speed heat/cool tap.

When voltage is applied to J49 pin 2 in addition to pin 3 and 15 (second stage heating), the blower is energized on the high speed heating tap. When voltage is applied to J49 pin 10 in addition to pin 3 and 15 (second stage cooling), the blower is energized on the high speed heating tap. The motor assigns priority to J49 pin 2 so that if a call for cooling and a call for heating are concurrent, heating call overrides and the blower operates on high speed heating tap.

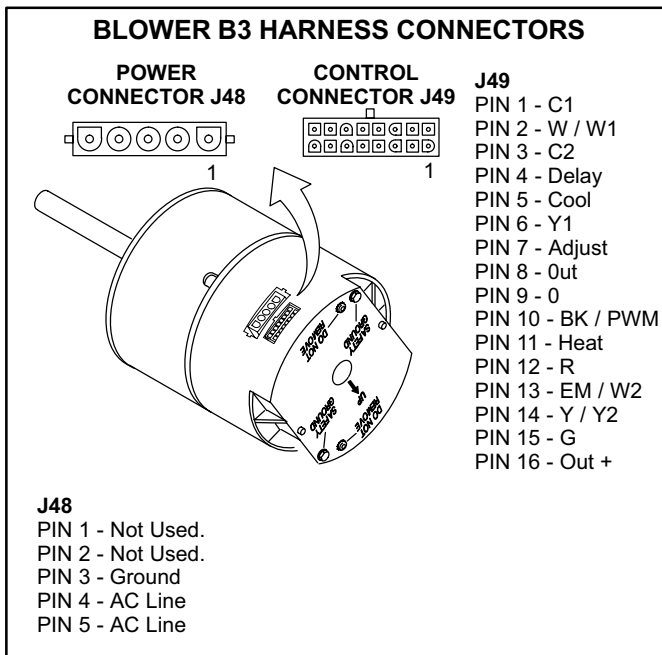

FIGURE 3

## **⚠ DANGER**

Do not attempt to repair electronically controlled blower motor module or BDC-2. There are no field serviceable parts. If either component appears to be faulty after following checkout procedure, replace entire component then recheck for proper operation.

## E-Precautions

If the CB21V or its electronically controlled blower motor is improperly or inadequately grounded, it may cause television interference (commonly known as RFI or radio frequency interference).

This interference is caused by internal switching frequencies of the motor controller (see figure 4). TV interference may show up as small specks or lines which randomly appear on the TV screen accompanied by pops or clicks in the sound. Before attempting any service, make sure the indoor unit is causing the interference. To check, disconnect power to indoor unit then check TV for continued signs of interference.

TV interference may be stopped by making sure the motor is solidly grounded to the cabinet (metal to metal) and by making sure the cabinet is solidly grounded. If TV interference persists, make sure the television (and all affected RF appliances) are moved away from the CB21V. Also make sure affected appliances are connected to a separate electrical circuit.

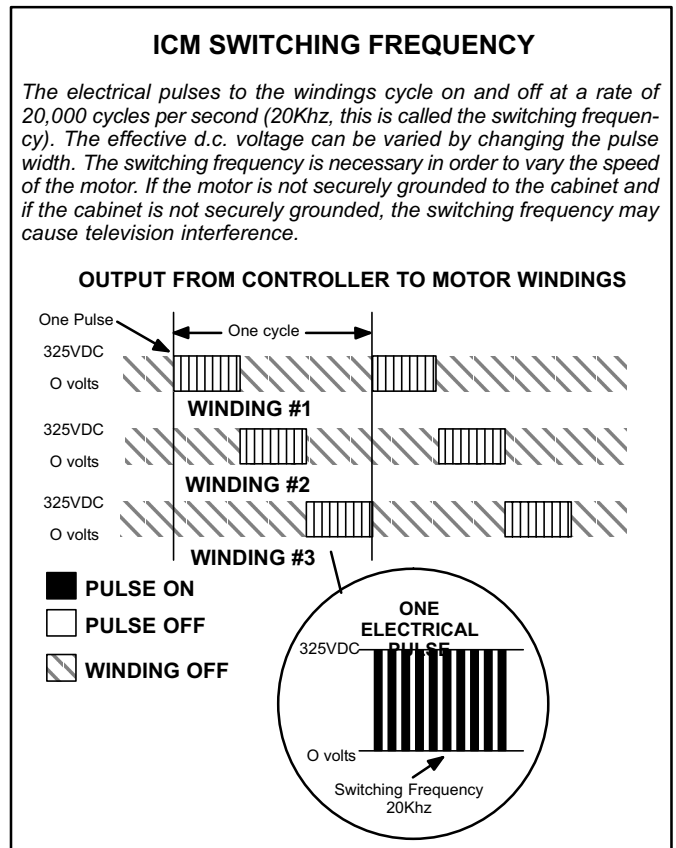
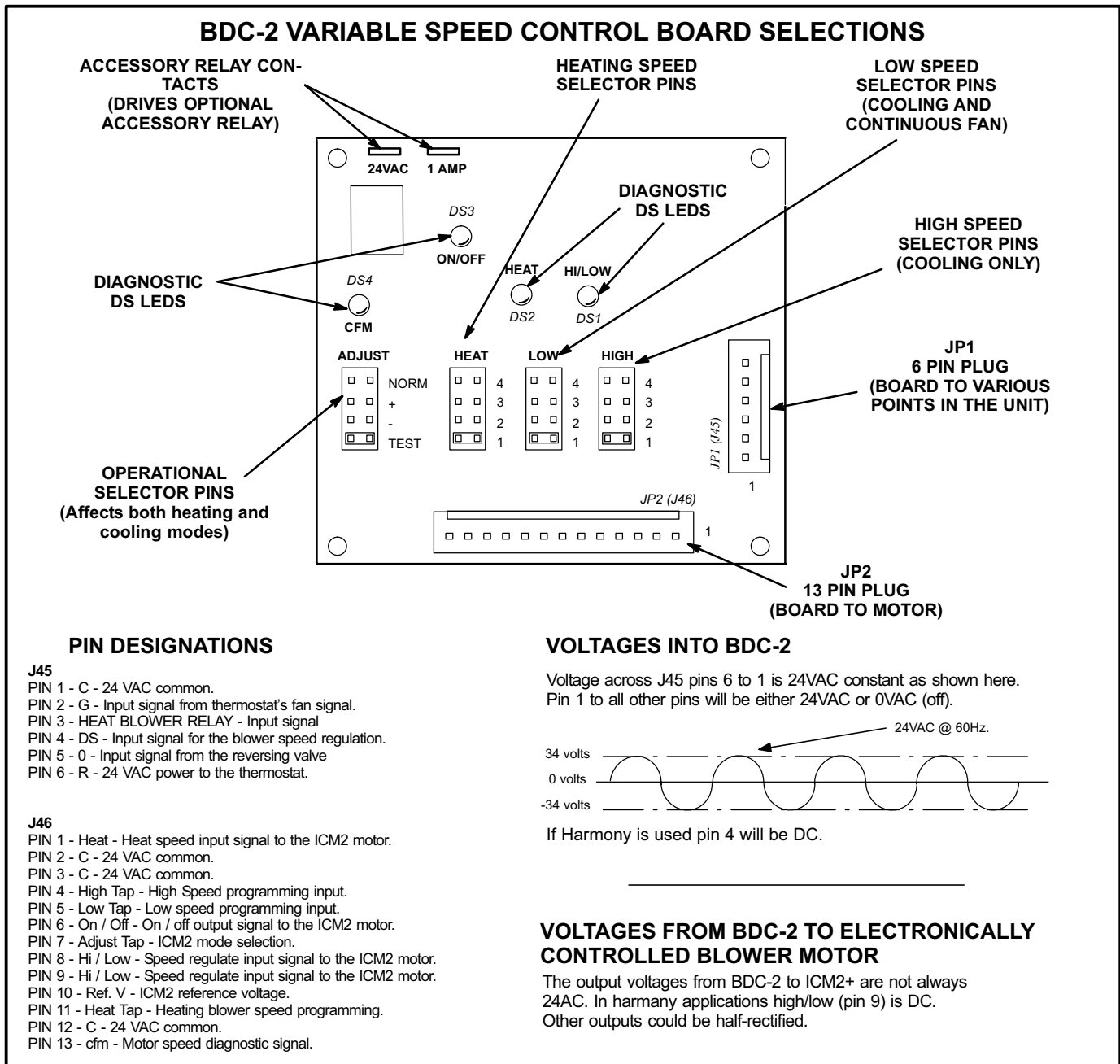

FIGURE 4

## II-BDC-2 Blower Control Board



**FIGURE 5**

CB21V and CBH21V units are equipped with a variable speed motor that is capable of maintaining a specified CFM throughout the external static range. A particular CFM can be obtained by positioning four jumpers (Low, High, Heat, and Adjust) on the BDC-2 control board. The Low, High, and Heat jumpers are labeled 1, 2, 3, and 4. This indicates the selected air volume (CFM). The adjust jumper is labeled Test, -, +, and Norm. The - and + pin settings are used to add or subtract a

percentage of the CFM selected. The Test jumper is used to operate the motor in the test mode.

Figure 5 shows the BDC-2 control board jumper settings. Refer to table 7 for factory set speed taps for High and Low speed cooling. Refer to table 8 for minimum blower speed tap for heating and table 9 for maximum speed tap for High speed cooling. Use tables 10 and 11 to determine the correct air volume for low and high speed cooling taps.

**TABLE 7  
FACTORY BLOWER SPEED TAP SELECTION**

BLOWER COIL	COOLING LOW SPEED	COOLING HIGH SPEED	HEAT SPEED
CB21V-41 CBH21V-41	2	1	1
CB21V-51 B21V/CH21-51	1	2	1
CB21V-65 B21V/CH21-65	3	3	2

**TABLE 8  
MINIMUM BLOWER SPEED TAPS FOR HEATING**

HEAT PUMP	BLOWER COIL	ELECTRIC HEAT ONLY	HEAT PUMP ONLY	HEAT PUMP WITH ELEC. HEAT
HP21-411	CB21V-41 CBH21V-41	3	1	3
HP21-511	CB21V-51 B21V/CH21-51	3	1	3
HP21-651	CB21V-65 B21V/CH21-65	3	2	4

**TABLE 9  
MAXIMUM BLOWER SPEED TAPS FOR COOLING**

HEAT PUMP	BLOWER COIL	WITH HEAT PUMP
HP21-411	CB21V-41 CBH21V-41	HIGH COOL 1
HP21-511	CB21V-51 B21V/CH21-51	HIGH COOL 2
HP21-651	CB21V-65 B21V/CH21-65	HIGH COOL 3

Diagnostic LEDs located on the BDC-2 control board are provided to aid in identifying the unit's mode of operation. Certain scenarios will arise depending on the jumper positions. Read through the diagnostic and jumper settings sections before adjusting blower speed. Refer to figure 5 for identification.

### Diagnostic LEDs

#### A-DS3 "ON/OFF"

**ON/OFF-DS3** indicates there is a demand for the blower motor to run. When the **ON/OFF** LED-DS3 is lit, a demand is being sent to the motor.

If **ON/OFF** LED-DS3 is on and both **HIGH/LOW** LED-DS1 & **HEAT** LED-DS2 are off, the motor will operate in low speed.

#### B-DS2 "HEAT"

If **HEAT** LED-DS2 is on, the blower is running in the heat speed according to the "HEAT" jumper setting. If the **HEAT** LED-DS2 is on at the same time as the **HIGH/LOW** LED-DS1, the blower is running in heat speed according to the "HEAT" jumper setting.

#### C-DS1 "HI/LOW"

**HIGH/LOW** LED-DS1 indicates whether the blower is operating in high or low speed. When the light is off, the blower is

running in low or heat speed according to the "LOW" or "HEAT" jumper setting. When **HIGH/LOW** LED-DS1 is on and the **HEAT** LED-DS2 is off, the blower is operating in high speed according to the "HIGH" jumper setting.

#### D-DS4 "CFM"

**CFM** LED-DS4 indicates the CFM the unit is operating according to the jumper settings. The light flashes once for approximately every 100 CFM. For example, if the unit is operating at 1000 CFM, **CFM** LED-DS4 will flash 10 times. If the CFM is 1150, **CFM** LED-DS4 will flash 11 full times plus one fast or half flash.

At times the light may appear to flicker or glow. This takes place when the control is communicating with the motor between cycles. This is normal operation.

The appropriate speed according to application and CFM need is selected by moving jumper pins.

### Jumper Settings

## IMPORTANT

**Before changing jumper setting, make sure the motor has completely stopped. Any jumper setting change will not take place while the motor is running.**

To change jumper positions, gently pull the jumper off the pins and place it on the desired set of pins. The following section outlines the different jumper selections available and conditions associated with each one. Refer to figure 5 for identification.

After the CFM for each application has been determined, the jumper settings must be adjusted to reflect those given in tables 10 and 11. Use the tables to determine which row of CFM volumes most closely matches the desired CFM. Once a specific row has been chosen (+, NORMAL, or -), CFM volumes from other rows cannot be used. Table 12 list the recommended blower speed jumper settings for CB21V series units. Below are the descriptions of each of the jumper selections.

#### A-"ADJUST"

The **ADJUST** pins allow the motor to run at normal speed, approximately 10% higher, or approximately 10% lower than normal speed. Table 10 and 11 give three rows (+, NORMAL, and -) with their respective CFM volumes. Notice that the normal adjustment setting for heat speed position #3 in table 11 is 1800 CFM. The + adjustment setting for that position is 2000 CFM and for the - adjustment setting is 1630 CFM. After the adjustment setting has been determined, chose the remainder speed jumper settings from those offered in the table in that row.

The TEST pin is available to bypass the BDC-2 control and run the motor at approximately 70% to test that the motor is operational. This is beneficial primarily in troubleshooting. G must be energized for motor to run.

**B-“HEAT”**

The **HEAT** jumper is used to set the blower speed to obtain the required CFM as outlined in HEAT SPEED section of tables 10 and 11.

**C-“HIGH”**

The **HIGH** jumper is used to determine the CFM during cooling speed. These jumper selections are activated when G and DS terminals are energized.

**D-“LOW”**

The **LOW** jumper is used to determine CFM during low speed cooling. These jumper selections are activated only when G is energized.

**TABLE 10**  
**CB21V-41 AND CBH21V-41 BLOWER PERFORMANCE**  
 (Operating at 0.00 through 0.60 in. w.g. External Static Pressure)

ADJUST JUMPER SETTING	LOW SPEED				HIGH (COOL) SPEED				HEAT SPEED			
	BDC-2 JUMPER POSITION				BDC-2 JUMPER POSITION				BDC-2 JUMPER POSITION			
	1	2	3	4	1	2	3	4	1	2	3	4
+	850	950	1060	1150	1150	1250	1490	1600	1230	1340	1480	1600
NORM	750	850	950	1025	1025	1125	1325	1425	1125	1225	1325	1425
-	650	730	830	900	900	1000	1190	1260	980	1080	1190	1260

NOTE: ADJUST position on BDC-2 (“NORM”, “+”, or “-”) determines the row of CFM available to use.

**TABLE 11**  
**CB21V-51, CBH21V-51, CB21V-65, CBH21V-65 AND B21V-51/65 BLOWER PERFORMANCE**  
 (Operating at 0.00 through 0.60 in. w.g. External Static Pressure)

ADJUST JUMPER SETTING	LOW SPEED				HIGH (COOL) SPEED				HEAT SPEED			
	BDC-2 JUMPER POSITION				BDC-2 JUMPER POSITION				BDC-2 JUMPER POSITION			
	1	2	3	4	1	2	3	4	1	2	3	4
+	935	1060	1265	1425	1650	1780	1955	2160	1650	1800	2000	2200
NORM	850	950	1150	1300	1500	1650	1800	1950	1500	1650	1800	1950
-	750	850	1025	1110	1350	1485	1560	1760	1340	1480	1630	1760

NOTE: ADJUST position on BDC-2 (“NORM”, “+”, or “-”) determines the row of CFM available to use.

**TABLE 12  
RECOMMENDED BLOWER SPEED JUMPER SETTINGS FOR CB21V SERIES UNITS**

BLOWER COIL UNIT MODEL NUMBER	OUTDOOR UNIT MODEL NUMBER	*RECOMMENDED BLOWER SPEED JUMPER SETTINGS			
		ADJUST JUMPER SETTING	COOLING HIGH SPEED JUMPER SETTING	COOLING & CONT. FAN LOW SPEED JUMPER SETTING	HEAT JUMPER SETTING *** (HEAT PUMP ONLY)
CB21V-41 CBH21V-41	HP14-261/411V, HP14-213/413V	NORM	1	2	2
	HP19-311, HP21-411, HP21-413	NORM	1	2	1
	HP18-461V, HP20-461	NORM	2	2	2
	HP18-411V, HP18-413V, HP20-411, HP19-411, HP19-413, HP22-411, HP25-411, HP26-411	+	2	1	1
	HS18-411, HS18-413, HS18-461, HS18-463, HS16-411V, HS16-461V, HS19-411V, HS19-413V, HS19-461V, HS19-463V, HS22-411V, HS22-461V, HS14-411V, HS14-413V, HS20-411, HS21-411, HS21-413, HS25-411, HS25-461, HS26-411, HS26-461	+	2	1	***
	HS20-461	NORM	4	2	***
CB21V-51 CBH21V-51	HP19-411, HP19-413, HP22-411	-	1	2	2
	HP18-461V, HP19-461, HP19-463, HP20-461, HP22-461, HP25-461, HP26-461	NORM	1	1	2
	HP18-511V, HP18-513V, HP19-511, HP19-513, HP14-311/511V, HP14-313/513V, HP21-511, HP21-513	NORM	2	1	1
	HS18-411, HS18-413, HS16-411V, HS19-411V, HS19-413V, HS22-411V HS20-411, HS25-461, HS26-461	-	1	1	***
	HS18-461, HS18-463, HS18-511, HS18-513, HS16-461V, HS16-511V, HS16-513V, HS19-461V, HS19-463V, HS19-511V, HS19-513V, HS22-461V HS20-461	NORM	1	1	***
	HS14-411V, HS14-413V HS21-411, HS21-413	-	1	1	***
	HS14-511V, HS14-513V HS21-511, HS21-513	NORM	2	1	***
	HS14-651V, HS14-653V HS21-651, HS21-653	+	3	2	***
CB21V-65 CBH21V-65	HS18-651, HS18-653, HP18-651V, HP18-653V, HP19-651, HP19-653, HP14-411/651V, HP14-413/653V, HP21-651, HP21-653, HS16-651V, HS19-651V, HS19-653V, HS14-651V, HS14-653V HS21-651, HS21-653	+	3	3	2
	HP19-511, HP19-513, HS18-511, HS18-513, HS16-511V, HS16-513V, HS19-511V, HS19-513V, HS14-511V, HS14-513V HS21-511, HS21-513	-	3	3	***

\*Necessary to achieve published ratings. See installation instructions for methods of changing speed.

\*\*Speeds shown for heat pump match without electric heat. For combinations with electric heat, see ECB21 installation instructions for appropriate speed settings and method of changing speed taps.

\*\*\*For application with electric heat, see CB21V and ECB21 installation instructions.

### III-ICM-2 Check-Out

To check-out the ICM-2 blower motor and the BDC-2 blower control board, begin with the ICM-2 blower. Refer to figure 6 and follow the check-out procedure as outlined. If

motor operates properly using the method in figure 6 , check the BDC-2 board. If motor fails, then change out the control module only (figure 1) .

#### ICM-2 CHECK-OUT

**120V to the motor must not be interrupted. All connections for check out will be from the voltage source below (battery or 24V) to plug J46, after disconnecting from blower control board; VSP2 or BDC-2.**

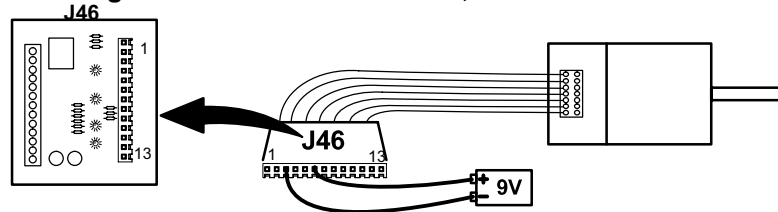

#### CHECK-OUT PROCEDURE USING BATTERY

*An ordinary 9 volt battery with maximum DC 20volts is recommended. A 9 volt battery will last for about one day of normal operation.*

##### LOW SPEED CHECK-OUT

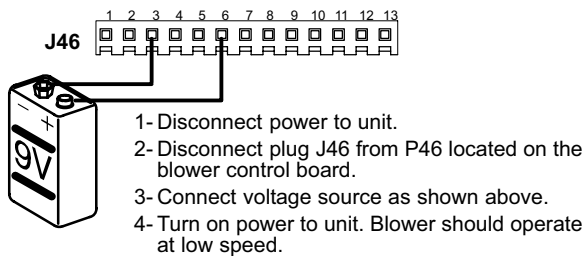

##### HIGH SPEED CHECK-OUT

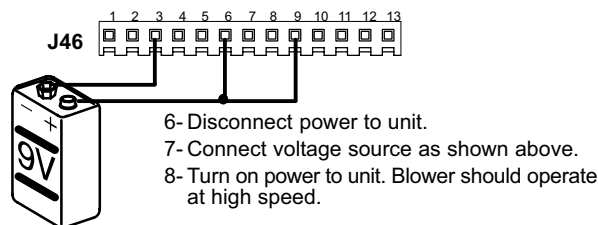

##### HEATING SPEED CHECK-OUT

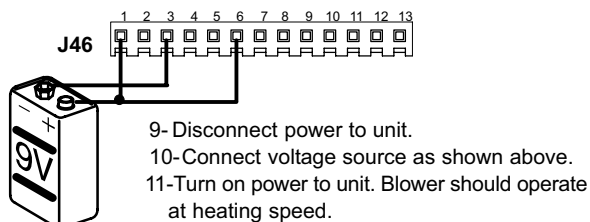

#### CHECK-OUT PROCEDURE USING 24V SOURCE

*Unit transformer T1 with a maximum AC 30 volts may be used in lieu of a battery. If transformer T1 is used, double check all wiring connections before placing unit back in operation.*

##### LOW SPEED CHECK-OUT

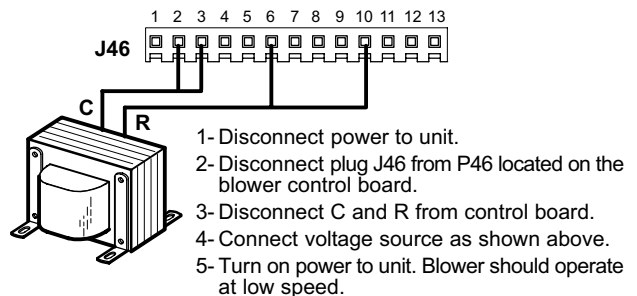

##### HIGH SPEED CHECK-OUT

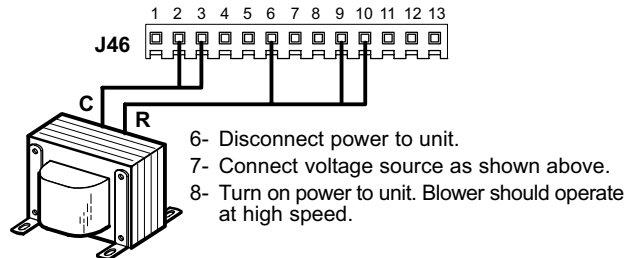

##### HEATING SPEED CHECK-OUT

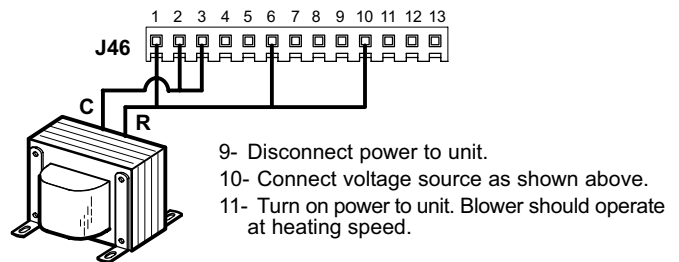

A kit is available from the Lennox parts center to use in testing the variable speed motor. The kit 70J11 includes a test plug harness to facilitate ICM-2 check-out. **Follow testing procedures outlined in the instructions provided with the kit. The testing procedures are different than those listed above.**

FIGURE 6

# IV - WIRING DIAGRAMS AND SEQUENCE OF OPERATION

## CB21 WITH ICM2+ MOTOR OPERATING SEQUENCE

FIELD WIRING FOR ECB21 UNITS  
WITHOUT CIRCUIT BREAKERS

FIELD WIRING FOR ECB21  
UNITS WITH CIRCUIT BREAKERS

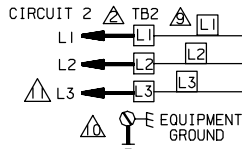

CONNECT POWER WIRES FROM HEATER LABELED L1, L2 ON "P" VOLTAGE UNITS AND L1, L2, L3 ON "Y" VOLTAGE UNITS TO TB2 TERMINAL STRIP IN INDOOR UNIT.

REFER TO FACTORY BLOWER SPEED TAP SELECTION CHART ON UNIT FOR BLOWER SPEED INFORMATION

USE COPPER CONDUCTORS ONLY. REFER TO UNIT NAMEPLATE FOR MINIMUM CIRCUIT AMPACITY AND MAXIMUM OVERCURRENT PROTECTION SIZE

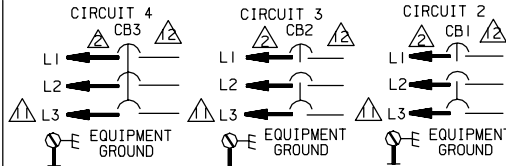

EQUIPMENT GROUND LOCATED IN INDOOR UNIT  
L3 IS NOT PRESENT ON (P) ELECTRIC HEATERS

THE NUMBER OF CIRCUITS VARY ACCORDING TO HEATER MODEL. REFER TO FAN COIL NAMEPLATE FOR ACTUAL NUMBER EMPLOYED

KEY	DESCRIPTION
CB1	CIRCUIT BRKR-ELECT HT
CB2	CIRCUIT BRKR-ELECT HT
CB3	CIRCUIT BRKR-ELECT HT
TB2	TERMINAL STRIP-UNIT

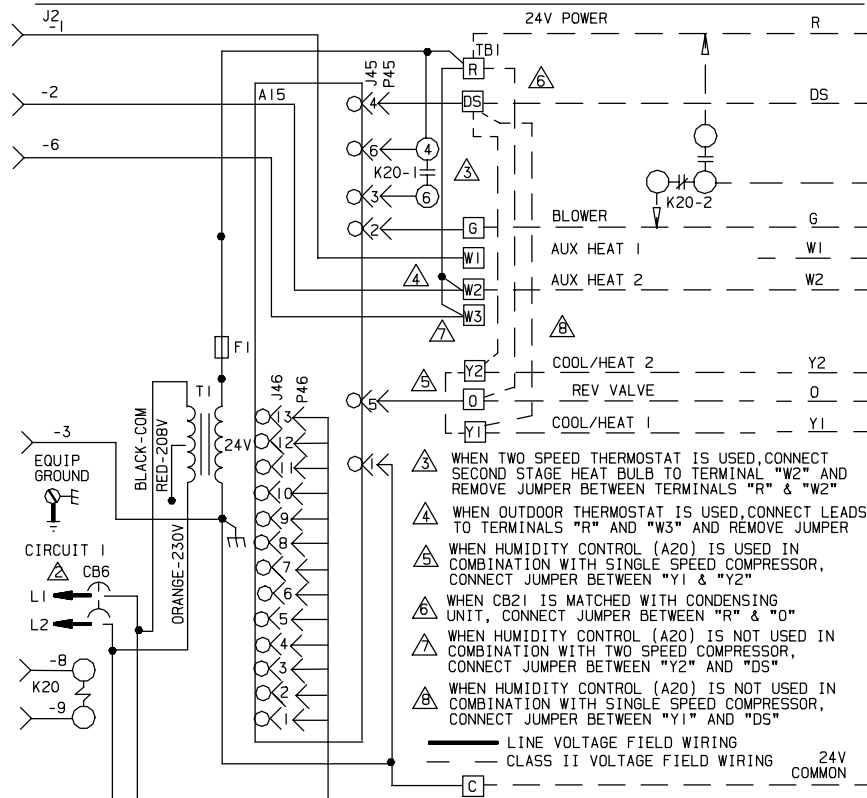

- WHEN TWO SPEED THERMOSTAT IS USED, CONNECT SECOND STAGE HEAT BULB TO TERMINAL "W2" AND REMOVE JUMPER BETWEEN TERMINALS "R" & "W2"
- WHEN OUTDOOR THERMOSTAT IS USED, CONNECT LEADS TO TERMINALS "R" AND "W3" AND REMOVE JUMPER
- WHEN HUMIDITY CONTROL (A20) IS USED IN COMBINATION WITH SINGLE SPEED COMPRESSOR, CONNECT JUMPER BETWEEN "Y1" & "Y2"
- WHEN CB21 IS MATCHED WITH CONDENSING UNIT, CONNECT JUMPER BETWEEN "R" & "O"
- WHEN HUMIDITY CONTROL (A20) IS NOT USED IN COMBINATION WITH TWO SPEED COMPRESSOR, CONNECT JUMPER BETWEEN "Y2" AND "DS"
- WHEN HUMIDITY CONTROL (A20) IS NOT USED IN COMBINATION WITH SINGLE SPEED COMPRESSOR, CONNECT JUMPER BETWEEN "Y1" AND "DS"

— LINE VOLTAGE FIELD WIRING  
- - - CLASS II VOLTAGE FIELD WIRING

KEY	DESCRIPTION
A15	CONTROL - BLOWER DRIVE
B3	MOTOR - BLOWER
CB6	CIRCUIT BRKR-BLO MTR
F1	FUSE - TRANSFORMER
J45	JACK - INPUT
J46	JACK - OUTPUT
J48	JACK - MOTOR, VAR SPD
J49	JACK - MOTOR, VAR SPD
K20, -1, 2	RELAY - BLOWER
J2	JACK - ELECT. HEAT
P45	PLUG - INPUT
P46	PLUG - OUTPUT
P48	PLUG - MOTOR, VAR SPD
P49	PLUG - MOTOR, VAR SPD
T1	TRANSFORMER - CONTROL
TB1	TERM STRIP - CLASS II VOLT

**LENNOX** Industries Inc. WIRING DIAGRAM 8/94

COILS-BLOWER COIL UNITS  
CB21V-41, 51, 65-TXV-3-P  
CBH21V-41-TXV-3-P  
B21V-51, 65-2P

COIL SECTION-1B46

Supersedes Form No. 529, 853W	New Form No. 531, 278W
----------------------------------	---------------------------

© 1994 Lennox Industries Inc. Litho U.S.A.