

XP19 SERIES UNITS

The XP19 is a high efficiency residential split-system heat pump unit, which features a two-step scroll compressor and R410A refrigerant. XP19 units are available in 2, 3, 4 and 5 ton sizes. The series is designed for use with an expansion valve only (approved for use with R410A) in the indoor unit. This manual is divided into sections which discuss the major components, refrigerant system, charging procedure, maintenance and operation sequence. Information contained in this manual is intended for use by qualified service technicians only. All specifications are subject to change.



⚠ CAUTION
Physical contact with metal edges and corners while applying excessive force or rapid motion can result in personal injury. Be aware of, and use caution when working nearby these areas during installation or while servicing this equipment.

⚠ CAUTION
To prevent personal injury, or damage to panels, unit or structure, be sure to observe the following:
While installing or servicing this unit, carefully stow all removed panels out of the way, so that the panels will not cause injury to personnel, nor cause damage to objects or structures nearby, nor will the panels be subjected to damage (e.g., being bent or scratched).
While handling or stowing the panels, consider any weather conditions, especially windy conditions, that may cause panels to be blown around and battered.

⚠ WARNING
Improper installation, adjustment, alteration, service or maintenance can cause property damage, personal injury or loss of life. Installation and service must be performed by a qualified installer or service agency.

⚠ DANGER
Shock Hazard
Remove all power at disconnect before removing access panel. XP19 units use single-pole contactors. Potential exists for electrical shock resulting in injury or death. Line voltage exists at all components (even when unit is not in operation).



Table of Contents

General	1	IV Charging	20
Specifications / Electrical Data	2	V Service and Recovery	24
I Application	3	VI Maintenance	24
II Unit Components	3	VII Brazing Procedure	24
III Refrigerant System	18	VIII Diagrams and Operating Sequence	25

SPECIFICATIONS

General Data		Model No.	XP19-024	XP19-036	XP19-048	XP19-060
Nominal Tonnage (kW)			2 (7.0)	3 (10.6)	4 (14.1)	5 (17.6)
Connections (sweat)	Liquid line (o.d.) - in. (mm)		3/8 (9.5)	3/8 (9.5)	3/8 (9.5)	3/8 (9.5)
	Vapor line (o.d.) - in. (mm)		7/8 (22.2)	7/8 (22.2)	7/8 (22.2)	1-1/8 (28.6)
Refrigerant	¹ R-410A charge furnished		12 lbs. 0 oz. (5.4 kg)	12 lbs. 5 oz. (5.6 kg)	13 lbs. 8 oz. (6.1 kg)	16 lbs. 5 oz. (7.4 kg)
Outdoor Coil	Net face area - sq. ft. (m ²)	Outer coil	20.50 (1.90)	20.50 (1.90)	26.92 (2.50)	26.92 (2.50)
		Inner coil	19.86 (1.85)	19.86 (1.85)	26.07 (2.42)	26.07 (2.42)
	Tube diameter - in. (mm)	5/16 (0.52)	5/16 (0.52)	5/16 (0.52)	5/16 (0.52)	
	No. of rows	2	2	2	2	
	Fins per inch (m)	22 (866)	22 (866)	22 (866)	22 (866)	
Outdoor Fan	Diameter - in. (mm)		26 (660)	26 (660)	26 (660)	26 (660)
	No. of blades		3	3	3	3
	Motor hp (W)		1/3 (249)	1/3 (249)	1/3 (249)	1/3 (249)
	Cfm (L/s) 1st stage		2500 (1180)	2500 (1180)	2800 (1320)	2800 (1320)
	2nd stage		2500 (1180)	2800 (1320)	3400 (1605)	3400 (1605)
	Rpm - 1st stage		700	700	700	700
	2nd stage		700	820	820	820
	Watts - 1st stage		70	70	150	150
	2nd stage		70	105	220	220
Shipping Data - lbs. (kg) 1 pkg.			304 (138)	315 (143)	352 (160)	387 (176)

ELECTRICAL DATA

Line voltage data - 60hz		208/230V-1ph	208/230V-1ph	208/230V-1ph	208/230V-1ph
³ Maximum overcurrent protection (amps)		25	40	50	60
² Minimum circuit ampacity		15.7	23.7	29.3	34.9
Compressor	Rated load amps	10.3	16.7	21.2	25.7
	Locked rotor amps	52	82	96	118
	Power factor	0.98	0.98	0.98	0.98
Outdoor Coil Fan Motor	Full load amps	2.8	2.8	2.8	2.8

OPTIONAL ACCESSORIES - must be ordered extra

Compressor Hard Start Kit	10J42	•	•		
	81J69			•	•
Compressor Low Ambient Cut-Off	45F08	•	•	•	•
Freezestat	3/8 in. tubing	93G35	•	•	•
	1/2 in. tubing	39H29	•	•	•
	5/8 in. tubing	50A93	•	•	•
Indoor Blower Relay	40K58	•	•	•	•
Low Ambient Kit	68M04	•	•	•	•
Monitor Kit - Service Light	76F53	•	•	•	•
Mounting Base	69J07	•	•	•	•
Outdoor Thermostat Kit	Thermostat	56A87	•	•	•
	Mounting Box - US	31461	•	•	•
		Canada	33A09	•	•
SignatureStat™ Home Comfort Control	81M28	•	•	•	•
Refrigerant Line Sets	L15-65-15	L15-65-40	•	•	•
	L15-65-30	L15-65-50			
	Field Fabricate				•
Time Delay Relay	58M81	•	•	•	•

NOTE - Extremes of operating range are plus 10% and minus 5% of line voltage.

¹ Refrigerant charge sufficient for 15 ft. (4.6 m) length of refrigerant lines.

² Refer to National or Canadian Electrical Code manual to determine wire, fuse and disconnect size requirements.

³ HACR type breaker or fuse.

I-APPLICATION

All major components (indoor blower and coil) must be matched according to Lennox recommendations for the compressor to be covered under warranty. Refer to the Engineering Handbook for approved system matchups. A misapplied system will cause erratic operation and can result in early compressor failure.

II-Unit Components

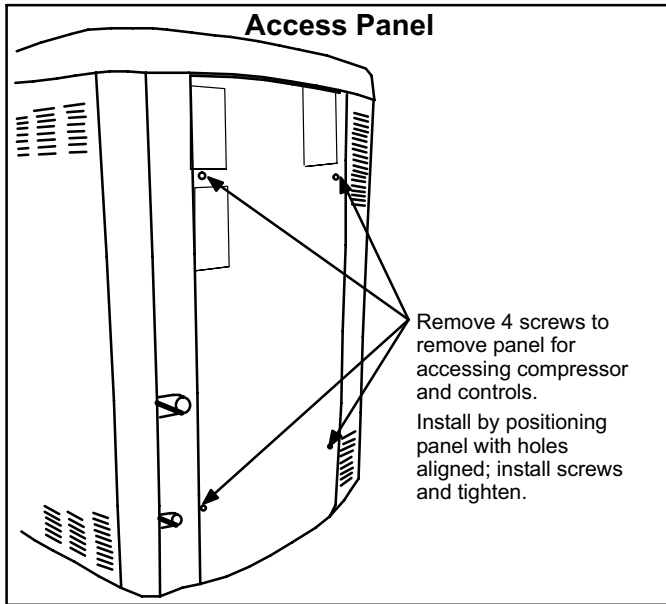

FIGURE 1

Removing Access Panels

Remove and reinstall the *access panel* as described in figure 1.

Remove the *louvered panels* as follows:

- 1-. Remove 2 screws, allowing the panel to swing open slightly.
- 2-. **Hold the panel firmly throughout this procedure.** Rotate bottom corner of panel away from hinge corner post until lower 3 tabs clear the slots (see figure 2, Detail B).
- 3-. Move panel down until lip of upper tab clears the top slot in corner post (see figure 2, Detail A).

Position and Install Panel—Position the panel almost parallel with the unit (figure 2, Detail D) with the “screw side” as close to the unit as possible. Then, in a continuous motion:

Slightly rotate and guide the LIP of top tab inward (figure 2, Details A and C); then upward into the top slot of the hinge corner post.

Rotate panel to vertical to fully engage all tabs.

Holding the panel's hinged side firmly in place, close the right-hand side of the panel, aligning the screw holes.

When panel is correctly positioned and aligned, insert the screws and tighten.

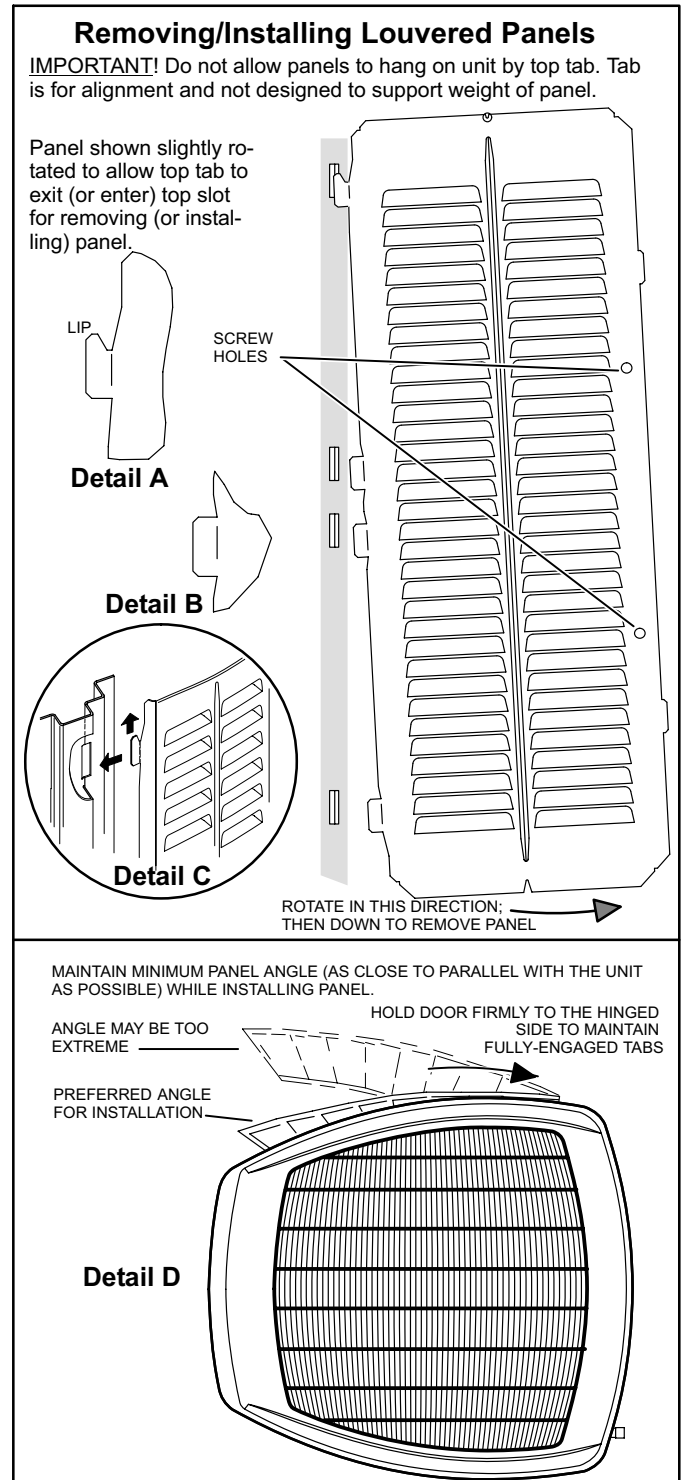

FIGURE 2

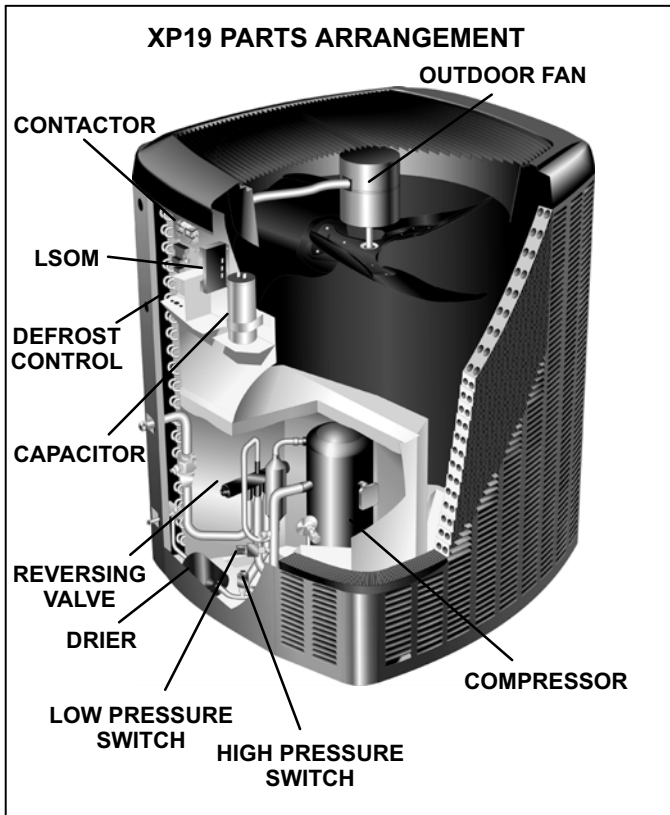

FIGURE 3

**ELECTROSTATIC DISCHARGE (ESD)
Precautions and Procedures**

⚠ CAUTION

Electrostatic discharge can affect electronic components. Take precautions during unit installation and service to protect the unit's electronic controls. Precautions will help to avoid control exposure to electrostatic discharge by putting the unit, the control and the technician at the same electrostatic potential. Neutralize electrostatic charge by touching hand and all tools on an unpainted unit surface before performing any service procedure.

A-Two-Stage Scroll Compressor (B1)

The scroll compressor design is simple, efficient and requires few moving parts. A cutaway diagram of the scroll compressor is shown in figure 1. The scrolls are located in the top of the compressor can and the motor is located just below. The oil level is immediately below the motor.

The scroll is a simple compression concept centered around the unique spiral shape of the scroll and its inherent properties. Figure 5 shows the basic scroll form. Two identical scrolls are mated together forming concentric spiral shapes (figure 6). One scroll remains stationary, while the other is allowed to "orbit" (figure 7). Note that the orbiting scroll does not rotate or turn but merely "orbits" the stationary scroll.

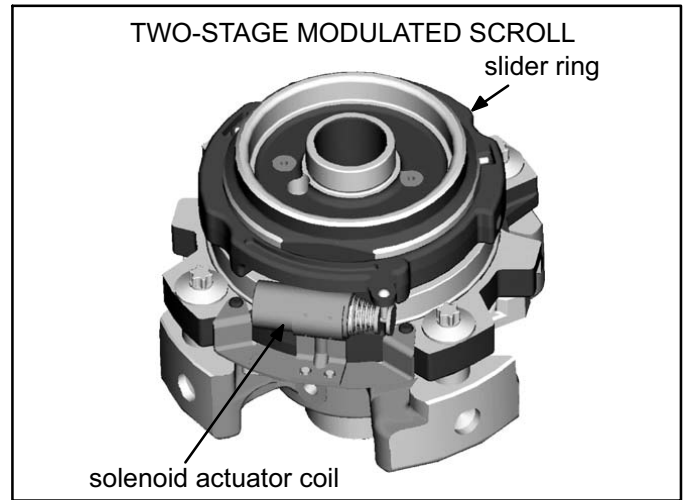

FIGURE 4

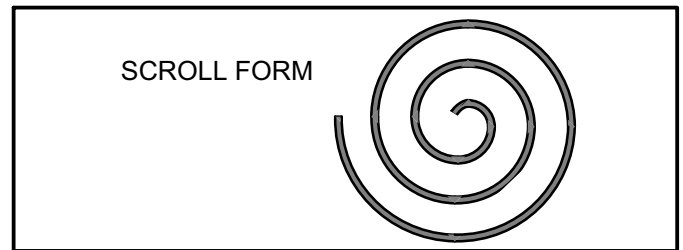

FIGURE 5

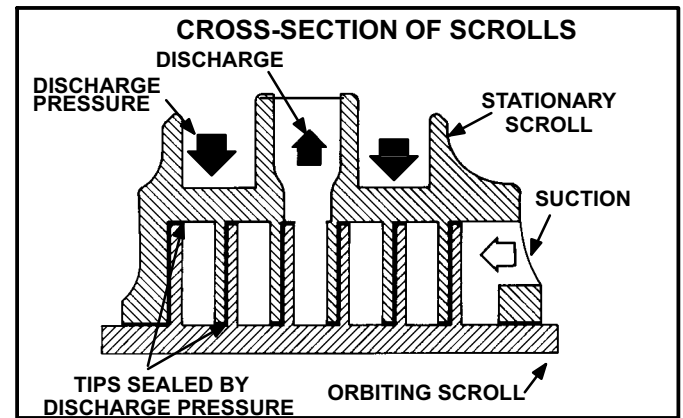

FIGURE 6

The counterclockwise orbiting scroll draws gas into the outer crescent shaped gas pocket created by the two scrolls (figure 7 - 1). The centrifugal action of the orbiting scroll seals off the flanks of the scrolls (figure 7 - 2). As the orbiting motion continues, the gas is forced toward the center of the scroll and the gas pocket becomes compressed (figure 7 -3). When the compressed gas reaches the center, it is discharged vertically into a chamber and discharge port in the top of the compressor (figure 7 - 4). The discharge pressure forcing down on the top scroll helps seal off the upper and lower edges (tips) of the scrolls (figure 6). During a single orbit, several pockets of gas are compressed simultaneously providing smooth continuous compression.

The scroll compressor is tolerant to the effects of liquid return. If liquid enters the scrolls, the orbiting scroll is allowed to separate from the stationary scroll. The liquid is worked toward the center of the scroll and is discharged.

Due to its efficiency, the scroll compressor is capable of drawing a much deeper vacuum than reciprocating compressors. Deep vacuum operation can cause internal fuse arcing resulting in damaged internal parts and will result in compressor failure. This type of damage can be detected and will result in denial of warranty claims. The scroll compressor can be used to pump down refrigerant as long as the pressure is not reduced below 7 psig.

NOTE - During operation, the head of a scroll compressor may be hot since it is in constant contact with discharge gas.

The scroll compressors in all XP19 model units are designed for use with R410A refrigerant and operation at high pressures. Compressors are shipped from the factory with 3MA (32MMA) P.O.E. oil. See electrical section in this manual for compressor specifications.

TWO-STAGE OPERATION

The two-stage scroll compressor operates like any standard scroll compressor with the exception the two-stage compressor modulates between first stage (low capacity approximately 67%) and second stage (high capacity). Modulation occurs when gas is bypassed through bypass ports (figure 8 bypass ports open) in the first suction pocket. This bypassing of gas allows the compressor to operate on first stage (low capacity) if thermostat demand allows. Indoor thermostat setting will determine first or second stage operation. The compressor will operate on first-stage until demand is satisfied or the indoor temperature reaches the thermostat set point calling for second-stage.

Second-stage (high capacity) is achieved by blocking the bypass ports (figure 8 bypass ports closed) with a slider ring. The slider ring begins in the open position and is controlled by a 24VDC internal solenoid. On a Y2 call the internal solenoid closes the slider ring, blocking the bypass ports and bringing the compressor to high capacity. Two-stage modulation can occur during a single thermostat demand as the motor runs continuously while the compressor modulates from first-stage to second-stage.

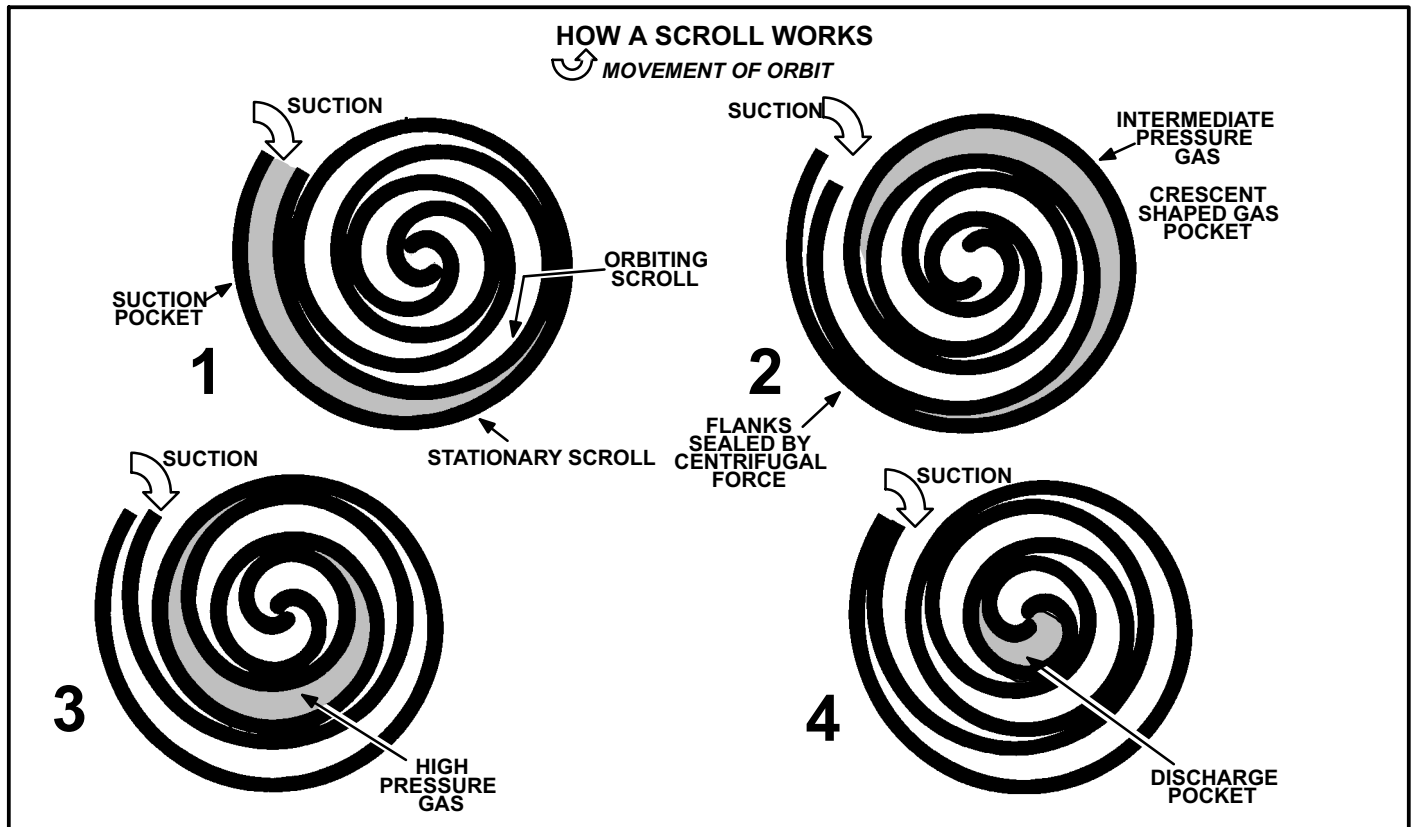

FIGURE 7

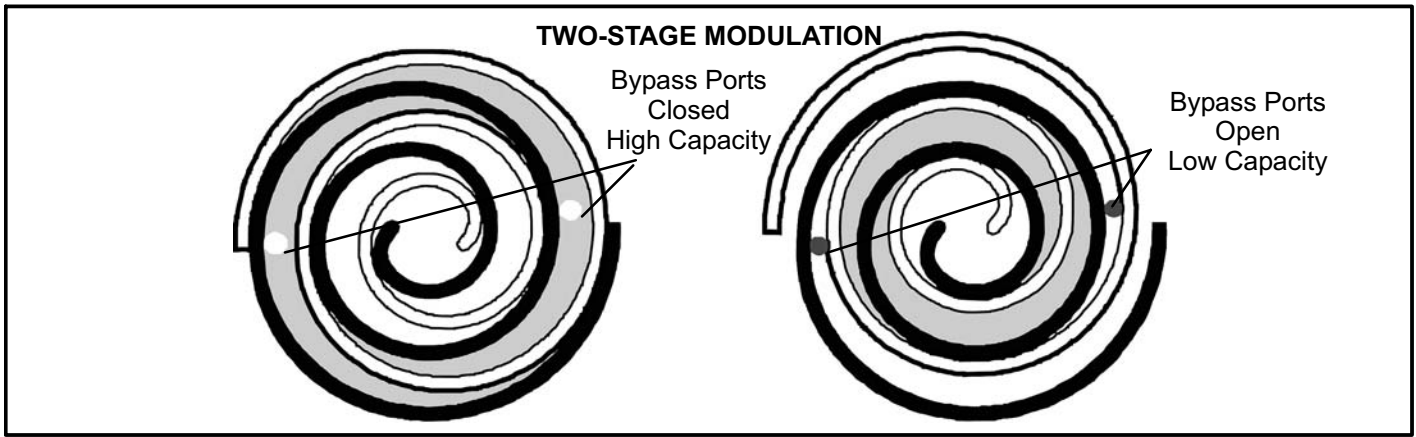

FIGURE 8

INTERNAL SOLENOID (L34)

The internal unloader solenoid controls the two-stage operation of the compressor by shifting a slide ring mechanism to open (low capacity) or close (high capacity), two by-pass ports in the first compression pocket of the scrolls in the compressor. The internal solenoid is activated by a **24 volt direct current solenoid coil**. The internal wires from the solenoid in the compressor are routed to a 2 pin fusite connection on the side of the compressor shell. The external electrical connection is made to the compressor with a molded plug assembly. The molded plug receives 24 volt DC power from the LSOM II.

If it is suspected the unloader is not operating properly, check the following

⚠ IMPORTANT

This performance check is ONLY valid on systems that have clean indoor and outdoor coils, proper air-flow over coils, and correct system refrigerant charge. All components in the system must be functioning proper to correctly perform compressor modulation operational check. (Accurate measurements are critical to this test as indoor system loading and outdoor ambient can affect variations between low and high capacity readings).

STEP 1 Confirm low to high capacity compressor operation

Tools required

- Refrigeration gauge set
- Digital volt/amp meter
- Electronic temperature thermometer
- On-off toggle switch

Procedure

- 1-. Turn main power "OFF" to outdoor unit.
- 2-. Adjust room thermostat set point above (heating operation on heat pump) or below (cooling operation) the room temperature 5°F.
- 3-. Remove control access panel. Install refrigeration gauges on unit. Attach the amp meter to the common (black wire) wire of the compressor harness. Attach thermometer to discharge line as close as possible to the compressor.
- 4-. Turn toggle switch "OFF" and install switch in series with Y2 wire from room thermostat.
- 5-. Cycle main power "ON."
- 6-. Allow pressures and temperatures to stabilize before taking any measured reading (may take up to 10 minutes).

NOTE - Block outdoor coil to maintain a minimum of 375 psig during testing).

- 7-. Record all of the readings for the Y1 demand on table 1.
- 8-. Close switch to energize Y2 demand.
- 9-. Allow pressures and temperatures to stabilize before taking any measured reading (this may take up to 10 minutes).
- 10-. Record all of the readings of Y2 demand on table 1.

NOTE - On new installations or installations that have shut down for an extended period of time, if the compressor does not cycle from low stage to high stage on the first attempt, it may be necessary to recycle the compressor back down to low stage and back up to high stage a few times in order to get the bypass seals to properly seat

Compare Y1 readings with Y2 readings in table 1. Some readings should be higher, lower or the same. If the readings follow what table 1 specifies, the compressor is operating and shifting to high capacity as designed. If the readings do not follow what table 1 specifies, continue to step 2 to determine if problem is with external solenoid plug power.

TABLE 1

Unit Readings	Compressor Operation		
	Y1 - 1st-Stage	Expected Results	Y2 - 2nd-Stage
Compressor			
Voltage		Same	
Amperage		Higher	
Condenser Fan motor			
Amperage		Same or Higher	
Temperature			
Ambient		Same	
Outdoor Coil Discharge Air		Higher in Cooling Lower in Heating	
Compressor Discharge Line		Higher	
Indoor Return Air		Same	
Indoor Coil Discharge Air		Lower in Cooling Higher in Heating	
Pressures			
Suction (Vapor)		Lower	
Liquid		Higher	

STEP 2 Confirm DC voltage output on compressor solenoid plug

- 1-. Shut power off to the outdoor unit.
- 2-. Insert lead wires from voltmeter into back of the red and black wire plug jack that feeds power to compressor solenoid coil. Set voltmeter to DC volt scale to read DC voltage output from LSOM II plug. See figure 9.

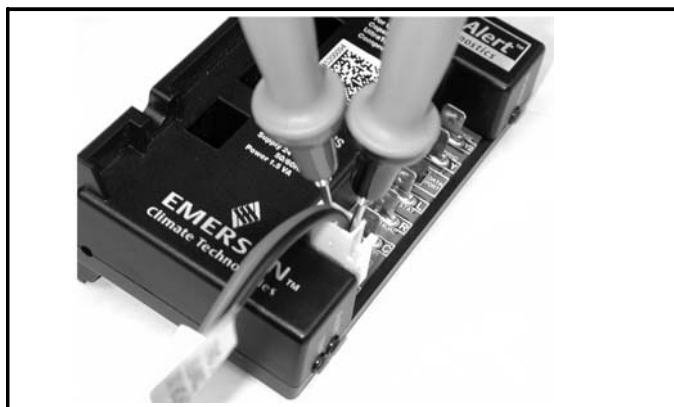

FIGURE 9

- 3-. Apply a Y1 and Y2 demand from the indoor thermostat to the LSOM II.
- 4-. Turn power back on to unit.
- 5-. Compressor should cycle "ON" when Y1 is calling.
- 6-. With Y2 calling, 5 seconds after compressor cycles "ON", LSOM II will output 24 volt DC signal to the compressor solenoid plug. Once the solenoid has pulled in, the LSOM II will reduce the DC voltage to a pulsating 6 to 18 volt DC output to the solenoid to allow the solenoid to remain energized.

⚠ IMPORTANT

When checking compressor for two-stage operation, always cycle Y1 to Y2 from terminals on the LSOMII or room thermostat connections. DO NOT cycle second stage (Y2) of compressor by unplugging the 24VDC solenoid LSOM II end of plug. The LSOM II will only output a 6 to 18VDC signal which will be insufficient voltage to pull the solenoid coil in for second stage.

If compressor solenoid is still not shifting to high capacity, this check will verify that DC power is being fed from the LSOM II.

- 7-. Shut power off to unit (main and low voltage)
- 8-. Unplug the 2 pin solenoid plug from the fusite connection on the compressor and the plug end from the LSOM II.
- 9-. Using an OHM meter, check for continuity on the plug harness wire ends (red to red, black to black). Wires should have continuity between same colors and no continuity between opposite color wires.

If the above checks verify that the solenoid plug is providing power to cycle into high capacity operation, continue to step 3 to determine if problem is with solenoid coil in compressor

STEP 3 Confirm internal unloader solenoid has proper resistance

- 1-. Shut all power off to unit (main and low voltage)
- 2-. Unplug the molded plug from the compressor solenoid 2-pin fusite.
- 3-. Using a volt meter set on the 200 ohm scale

Replace the Compressor under these conditions:

Bad Solenoid

a. Measure the resistance at the 2-pin fusite. The resistance should be 32 to 60 ohms depending on compressor temperature. If no resistance replace compressor.

b. Measure the resistance from each fusite pin to ground. There should **not be** continuity to ground. If solenoid coil is grounded, replace compressor.

Good Solenoid

a. Seals not shifting, replace compressor

b. Slider ring not shifting, replace compressor.

B-Contactor (K1)

The compressor is energized by a contactor located in the control box. All XP19 units are single phase and use single-pole contactors.

C-Low Pressure Switch (S87)

The XP19 is equipped with an auto-reset low pressure switch which is located on the suction line. The switch shuts off the compressor when the suction pressure falls below the factory setting. This switch is ignored during the first 90 seconds of compressor start up, during defrost operation, 90 seconds after defrost operation, during test mode and when the outdoor temperature drops below 15°F.

The switch closes when it is exposed to 55 psig and opens at 25 psig. It is not adjustable.

D-High Pressure Switch (S4)

⚠ IMPORTANT

Pressure switch settings for R410A refrigerant will be significantly higher than units with R22.

An auto-reset, single-pole/single-throw high pressure switch is located in the liquid line. This switch shuts off the compressor when liquid line pressure rises above the factory setting. The switch is normally closed and is permanently adjusted to trip (open) at 590 ± 15 psi and close at 418 ± 15 psi. See figure 3 for switch location.

E-Capacitor (C12)

The compressor in XP19-024, -036, -048 and -060 units use a permanent split capacitor (see unit wiring diagram). The capacitor is located inside the unit control box. Ratings are on capacitor side.

F-Condenser Fan with Variable Speed Motor(B4)

The variable speed condenser fan motor (figure 10) used in all units is a three-phase, electronically controlled d.c. brushless motor (controller converts single phase a.c. to three phase d.c.), with a permanent-magnet-type rotor, manufactured by GE. Because this motor has a permanent magnet rotor it does not need brushes like conventional D.C. motors. The motors consist of a control module and motor. Internal components are shown in figure 11. The stator windings are split into three poles which are electrically connected to the controller. This arrangement allows motor windings to be turned on and off in sequence by the controller.

The controller is primarily an a.c. to d.c. converter. Converted d.c. power is used to drive the motor. The controller contains a microprocessor which monitors varying conditions inside the motor (such as motor workload).

The controller uses sensing devices to know what position the rotor is in at any given time. By sensing the position of the rotor and then switching the motor windings on and off in sequence, the rotor shaft turns the blower.

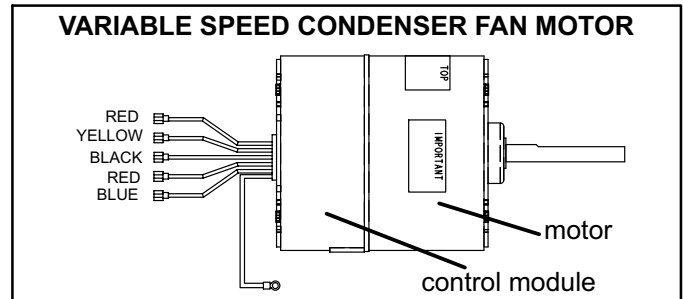

FIGURE 10

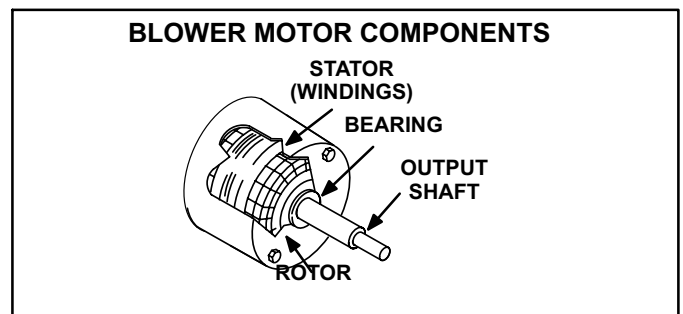

FIGURE 11

Internal Operation

The condenser fan motor is a variable speed motor with RPM settings at 700 (Y1) and 820 (Y2). The variation in speed is accomplished each time the controller switches a stator winding (figure 10) on and off, it is called a "pulse." The length of time each pulse stays on is called the "pulse width." By varying the pulse width the controller varies motor speed (called "pulse-width modulation"). This allows for precise control of motor speed and allows the motor to compensate for varying load conditions as sensed by the controller. In this case, the controller monitors the static workload on the motor and varies motor rpm in order to maintain constant airflow (cfm).

Motor rpm is continually adjusted internally to maintain constant static pressure against the fan blade. The controller monitors the static work load on the motor and motor amp-draw to determine the amount of rpm adjustment. Blower rpm is adjusted internally to maintain a constant cfm. The amount of adjustment is determined by the incremental taps which are used and the amount of motor loading sensed internally. The motor constantly adjusts rpm to maintain a specified cfm.

Initial Power Up

When line voltage is applied to the motor, there will be a large inrush of power lasting less than 1/4 second. This inrush charges a bank of DC filter capacitors inside the controller. If the disconnect switch is bounced when the disconnect is closed, the disconnect contacts may become welded. Try not to bounce the disconnect switch when applying power to the unit.

The DC filter capacitors inside the controller are connected electrically to the speed tap wires. The capacitors take approximately 5 minutes to discharge when the disconnect is opened. For this reason it is necessary to wait at least 5 minutes after turning off power to the unit before attempting to service motor.

⚠ DANGER



Disconnect power from unit and wait at least five minutes to allow capacitors to discharge before attempting to service motor. Failure to wait may cause personal injury or death.

Motor Start-Up

At start-up, the motor may gently rock back and forth for a moment. This is normal. During this time the electronic controller is determining the exact position of the rotor. Once the motor begins turning, the controller slowly eases the motor up to speed (this is called "soft-start"). The motor may take as long as 10-15 seconds to reach full speed. If the motor does not reach 200rpm within 13 seconds, the motor shuts down. Then the motor will immediately attempt a restart. The shutdown feature provides protection in case of a frozen bearing or blocked fan blade. The motor may attempt to start eight times. If the motor does not start after the eighth try, the controller locks out. Reset controller by momentarily turning off power to unit.

Troubleshooting

If first or second stage thermostat call for cool is present and the variable speed condenser fan motor does not energize, check voltage at the breaker box. If voltage is present do the following and reference figure 12.

- 1- Check for 240 volts between the compressor RED wires.
- 2- Initiate a first stage call for cool. Check for 24 volts between the fan motor YELLOW wire and fan motor BLACK wire.
- 3- Initiate a second stage call for cool. Check for 24 volts between the fan motor YELLOW wire and fan motor BLACK wire, then check for 24 volts between the fan motor BLUE wire and fan motor BLACK.
- 4- Repeat steps 1 and 2 with a HEAT call.

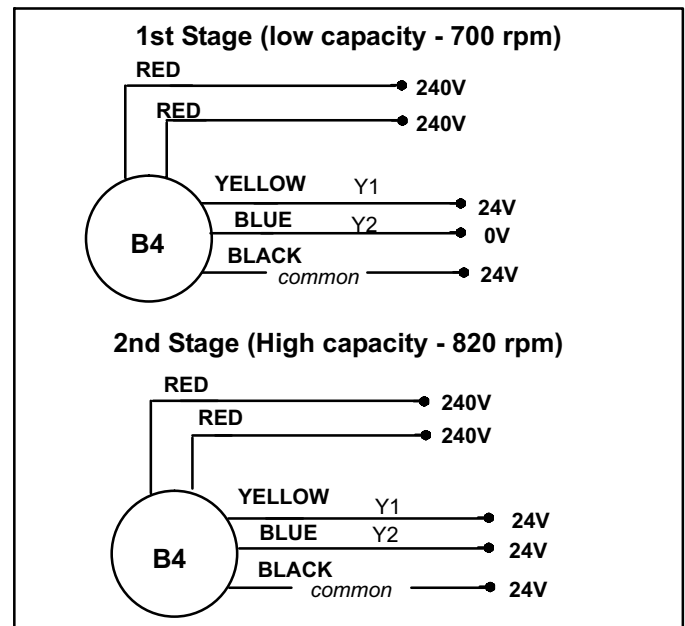

FIGURE 12

Replacement

See figure 13 if condenser fan motor replacement is necessary.

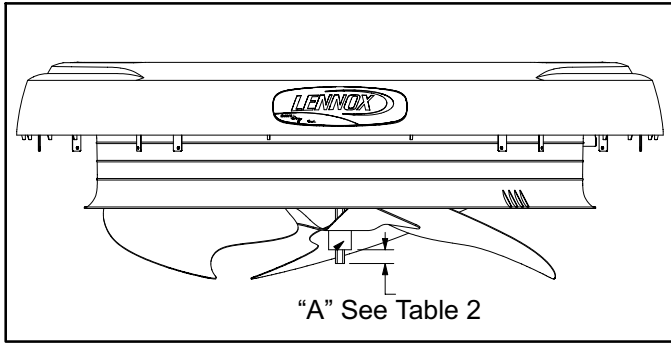

FIGURE 13

TABLE 2

XP19 UNIT	"A" DIM. $\pm 1/8"$
-024, -036	3/4"
-048, -060	Flush

G-Filter Drier

A filter drier designed for all XP19 model units is factory installed in the liquid line. The filter drier is designed to remove moisture and foreign matter, which can lead to compressor failure.

Moisture and / or Acid Check

Because POE oils absorb moisture, the dryness of the system must be verified any time the refrigerant system is exposed to open air. A compressor oil sample must be taken to determine if excessive moisture has been introduced to the oil. Table 3 lists kits available from Lennox to check POE oils.

If oil sample taken from a system that has been exposed to open air does not test in the dry color range, the filter drier MUST be replaced.

! IMPORTANT

Replacement filter drier MUST be approved for R410A refrigerant and POE application.

Foreign Matter Check

It is recommended that a liquid line filter drier be replaced when the pressure drop across the filter drier is greater than 4 psig.

H-Accumulator (XP19-060-1 and -2 only)

5 ton XP19-1 and -2 units are equipped with an accumulator. The purpose of the accumulator is to trap and evaporate all liquid refrigerant returning to the compressor.

TABLE 3

KIT	CONTENTS	TUBE SHELF LIFE
10N46 - Refrigerant Analysis	Checkmate-RT700	
10N45 - Acid Test Tubes	Checkmate-RT750A (three pack)	2 - 3 years @ room temperature. 3+ years refrigerated
10N44 - Moisture Test Tubes	Checkmate - RT751 Tubes (three pack)	6 - 12 months @ room temperature. 2 years refrigerated
74N40 - Easy Oil Test Tubes	Checkmate - RT752C Tubes (three pack)	2 - 3 years @ room temperature. 3+ years refrigerated
74N39 - Acid Test Kit	Sporlan One Shot - TA-1	

I-Lennox System Operation Monitor (A132)

The Lennox system operation monitor (LSOM) is a 24 volt powered module, (see diagnostic module A132 on wiring diagram and figure 14) wired directly to the indoor unit. The LSOM is located in the control box and is used to trouble shoot problems in the system. The module has three LED's for troubleshooting: GREEN indicates power status, YELLOW indicates an abnormal condition and RED indicates thermostat demand, but compressor not operating. See table 4 for troubleshooting codes.

The diagnostic indicator detects the most common fault conditions in the heat pump system. When an abnormal condition is detected, the module communicates the specific condition through its ALERT and TRIP lights. The module is capable of detecting both mechanical and electrical system problems. See figure 14 for the system operation monitor.

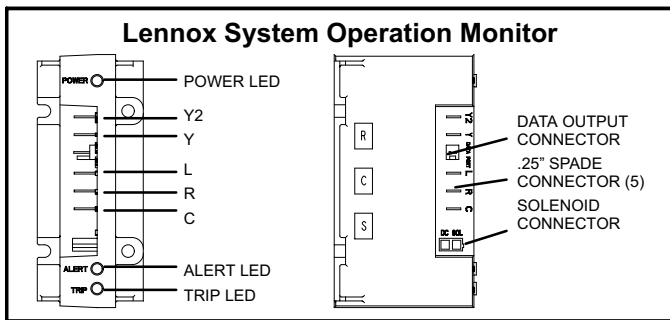

FIGURE 14

IMPORTANT - The LSOM is not a safety component and cannot shutdown or control the XP19. The LSOM is a monitoring device only.

LED Functions

Alert LED (green) - Indicates voltage within the range of 19-28VAC is present at the system monitor connections.

Alert LED (yellow) - communicates an abnormal system condition through a unique Flash Code— the alert LED flashes a number of times consecutively; then pauses; then repeats the process. This consecutive flashing correlates to a particular abnormal condition.

Trip LED (red) - indicates there is a demand signal from the thermostat but no current to the compressor is detected by the module.

Flash code number - corresponds to a number of LED flashes, followed by a pause, and then repeated.

Trip & Alert LEDs flashing simultaneously - indicates that the control circuit voltage is too low for operation. Reset ALERT flash code by removing 24VAC power from monitor. Last ALERT flash code will display for 1 minute after monitor is powered on.

Thermostat Second-Stage Cooling

The Lennox system operation monitor (LSOM) requires a two-stage room thermostat to operate properly.

Y2 room thermostat connection—While the compressor is not running, LSOM will not power the solenoid, regardless of the state of Y2. If alert codes 1 or 9 (see table 4) appear while the compressor is running, LSOM will turn off the solenoid to prevent solenoid damage from overheating conditions.

L terminal connection—The L connection is used to communicate alert codes to the room thermostat. On selected Lennox SignatureStat™ thermostats, a blinking "check" LED will display on the room thermostat and on select White-Rodgers room thermostats, an icon on the display will flash. Either will flash at the same rate as the LSOM yellow alert LED.

NOTE - ROOM THERMOSTAT WITH SERVICE OR CHECK LIGHT FEATURE - The room thermostat may blink the "Check" or "Service" LED or it may come on solid. Confirm fault by observing and interpreting the code from the LSOM yellow alert LED at the unit.

Y2 DC Solenoid Connector (DC SOL)—The 24VDC solenoid, which is internal to the compressor, will not operate properly if 24VAC is applied to the compressor solenoid terminals. A voltmeter attached to the DC SOL output will measure 4-18 VDC when the solenoid is energized.

Installation verification-LSOM—To verify correct LSOM installation, two functional tests can be performed. Disconnect power from the compressor and force a thermostat call for cooling. The red trip LED should turn on indicating a compressor trip as long as 24VAC is measured at the Y terminal. If the red LED does not function as described, refer to table 4 to verify the wiring. Disconnect power from the compressor and 24VAC power from LSOM. Remove the wire from the Y terminal of LSOM and reapply power to the compressor, allowing the compressor to run. The yellow alert LED will begin flashing a code 8 indicating a welded contactor. Disconnect power from the compressor and 24VAC power from the LSOM. While the LSOM is off, reattach the wire to the Y terminal. Reapply power to the compressor and 24VAC power to the LSOM; the yellow alert LED will flash the previous code 8 for one minute and then turn off. If the yellow LED does not function as described, refer to table 4 to verify the wiring.

Resetting alert codes—Alert codes can be reset manually or automatically:

Manual reset: Cycle the 24VAC power to LSOM off and on.

Automatic reset: After an alert is detected, the LSOM continues to monitor the compressor and system. When/if conditions return to normal, the alert code is turned off automatically.

TABLE 4

System Operation Monitor LED Troubleshooting Codes		
Status LED Condition	Status LED Description	Status LED Troubleshooting Information
Green "Power" LED ON	Module has power	24VAC control power is present at the module terminal.
Green "Power" LED OFF	Module not powering up	Determine/verify that both R and C module terminals are connected and voltage is present at both terminals.
Red "Trip" LED ON	System and compressor check out OK Thermostat demand signal Y1 is present, but compressor not running <i>NOTE - During 5-minute delay in defrost board, the red "trip" LED will be on.</i>	<ol style="list-style-type: none"> 1 Verify Y terminal is connected to 24VAC at contactor coil. 2 Verify voltage at contactor coil falls below 0.5VAC when off. 3 Verify 24VAC is present across Y and C when thermostat demand signal is present; if not present, Y and C wires are reversed. 1 Compressor protector is open. 2 Outdoor unit power disconnect is open. 3 Compressor circuit breaker or fuse(s) is open. 4 Broken wire or connector is not making contact. 5 Low pressure switch open if present in the system. 6 Compressor contactor has failed to close.
Red "Trip" & Yellow "Alert" LEDs Flashing	Simultaneous flashing.	Indicates that the control circuit voltage is too low for operation.
Yellow "Alert" Flash Code 1*	Long Run Time - Compressor is running extremely long run cycles	<ol style="list-style-type: none"> 1 Low refrigerant charge. 2 Evaporator blower is not running. 3 Evaporator coil is frozen. 4 Faulty metering device. 5 Condenser coil is dirty. 6 Liquid line restriction (filter drier blocked if present). 7 Thermostat is malfunctioning.
Yellow "Alert" Flash Code 2*	System Pressure Trip or Discharge Sensor Fault - Discharge or suction pressure out of limits or compressor overloaded	<ol style="list-style-type: none"> 1 Check high head pressure or discharge line sensor. 2 Condenser coil poor air circulation (dirty, blocked, damaged). 3 Condenser fan is not running. 4 Return air duct has substantial leakage. 5 If low pressure switch is present, see Flash Code 1 information.
Yellow "Alert" Flash Code 3*	Short Cycling - Compressor is running only briefly	<ol style="list-style-type: none"> 1 Thermostat demand signal is intermittent. 2 Time delay relay or control board is defective. 3 If high pressure switch is present, see Flash Code 2 information. 4 If discharge sensor is present, see Flash Code 2 information.
Yellow "Alert" Flash Code 4*	Locked Rotor	<ol style="list-style-type: none"> 1 Run capacitor has failed. 2 Low line voltage (contact utility if voltage at disconnect is low). 3 Excessive liquid refrigerant in the compressor. 4 Compressor bearings are seized.
Yellow "Alert" Flash Code 5*	Open Circuit	<ol style="list-style-type: none"> 1 Outdoor unit power disconnect is open. 2 Unit circuit breaker or fuse(s) is open. 3 Unit contactor has failed to close. 4 High pressure switch is open and requires manual reset. 5 Open circuit in compressor supply wiring or connections. 6 Unusually long compressor protector reset time due to extreme ambient temperature. 7 Compressor windings are damaged.
Yellow "Alert" Flash Code 6*	Open Start Circuit - Current only in run circuit	<ol style="list-style-type: none"> 1 Run capacitor has failed. 2 Open circuit in compressor start wiring or connections. 3 Compressor start winding is damaged.
Yellow "Alert" Flash Code 7*	Open Run Circuit - Current only in start circuit	<ol style="list-style-type: none"> 1 Open circuit in compressor start wiring or connections. 2 Compressor start winding is damaged.
Yellow "Alert" Flash Code 8*	Welded Contactor - Compressor always runs	<ol style="list-style-type: none"> 1 Compressor contactor failed to open. 2 Thermostat demand signal not connected to module.
Yellow "Alert" Flash Code 9*	Low Voltage - Control circuit <17VAC	<ol style="list-style-type: none"> 1 Control circuit transformer is overloaded. 2 Low line voltage (contact utility if voltage at disconnect is low).

*Flash code number corresponds to a number of LED flashes, followed by a pause, and then repeated. Reset ALERT flash code by removing 24VAC power from monitor; last code will display for 1 minute after monitor is powered on.

J-Defrost System

The demand defrost controller measures differential temperatures to detect when the system is performing poorly because of ice build-up on the outdoor coil. The controller “self-calibrates” when the defrost system starts and after each system defrost cycle. The defrost control board components are shown in figure 15.

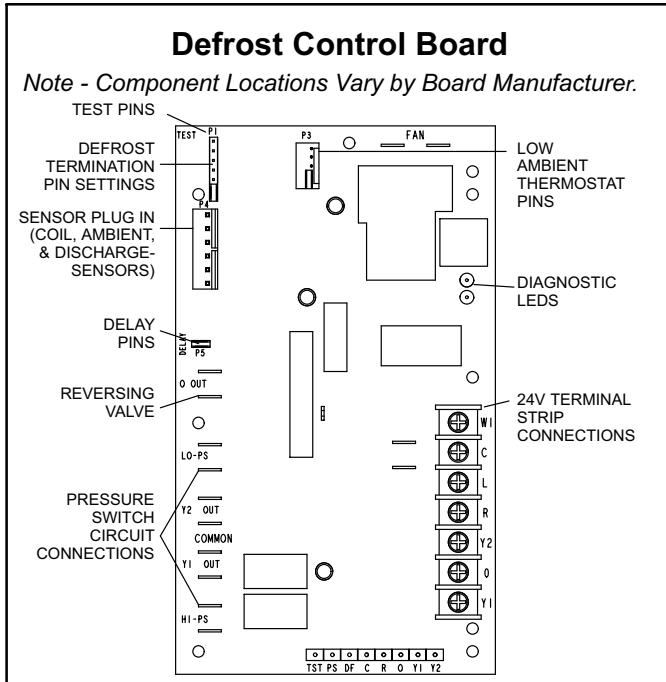

FIGURE 15

The control monitors ambient temperature, outdoor coil temperature, and total run time to determine when a defrost cycle is required. The coil temperature probe is designed with a spring clip to allow mounting to the outside coil tubing. The location of the coil sensor is important for proper defrost operation.

NOTE - The demand defrost board accurately measures the performance of the system as frost accumulates on the outdoor coil. This typically will translate into longer running time between defrost cycles as more frost accumulates on the outdoor coil before the board initiates defrost cycles.

Diagnostic LEDs

The state (Off, On, Flashing) of two LEDs on the defrost board (DS1 [Red] and DS2 [Green]) indicate diagnostics conditions that are described in table 6.

Defrost Board Pressure Switch Connections

The unit’s automatic reset pressure switches (LO PS - S87 and HI PS - S4) are factory-wired into the defrost board on the LO-PS and HI-PS terminals, respectively.

Low Pressure Switch (LO-PS)—When the low pressure switch trips, the defrost board will cycle off the compressor, and the strike counter in the board will count one strike. The low pressure switch is ignored under the following conditions:

during the defrost cycle and 90 seconds after the termination of defrost

when the average ambient sensor temperature is below 15° F (-9°C)

for 90 seconds following the start up of the compressor during “test” mode

High Pressure Switch (HI-PS)—When the high pressure switch trips, the defrost board will cycle off the compressor, and the strike counter in the board will count one strike.

Defrost Board Pressure Switch Settings

High Pressure (auto reset) - trip at 590 psig; reset at 418 psig.

Low Pressure (auto reset) - trip at 25 psig; reset at 40 psig.

5-Strike Lockout Feature

The internal control logic of the board counts the pressure switch trips only while the Y1 (Input) line is active. If a pressure switch opens and closes four times during a Y1 (Input), the control logic will reset the pressure switch trip counter to zero at the end of the Y1 (Input). If the pressure switch opens for a fifth time during the current Y1 (Input), the control will enter a lockout condition.

The 5-strike pressure switch lockout condition can be reset by cycling OFF the 24-volt power to the control board or by shorting the TEST pins between 1 and 2 seconds. All timer functions (run times) will also be reset.

If a pressure switch opens while the Y1 Out line is engaged, a 5-minute short cycle will occur after the switch closes.

Defrost System Sensors

Sensors connect to the defrost board through a field-replaceable harness assembly that plugs into the board. Through the sensors, the board detects outdoor ambient, coil, and discharge temperature fault conditions. As the detected temperature changes, the resistance across the sensor changes. Sensor resistance values can be checked by ohming across pins shown in table 5. The graph in figure 16 shows sensor temperature to resistance range.

NOTE - When checking the ohms across a sensor, be aware that a sensor showing a resistance value that is not within the range shown in table 5, may be performing as designed. However, if a shorted or open circuit is detected, then the sensor may be faulty and the sensor harness will need to be replaced.

TABLE 5

Sensor Temperature / Resistance Range			
Sensor	Temperature Range °F (°C)	Resistance values range (ohms)	Pins/Wire Color
Outdoor	-35 (-37) to 120 (48)	280,000 to 3750	3 & 4 (Black)
Coil	-35 (-37) to 120 (48)	280,000 to 3750	5 & 6 (Brown)
Discharge (if applicable)	24 (-4) to 350 (176)	41,000 to 103	1 & 2 (Yellow)

Note: Sensor resistance increases as sensed temperature decreases.

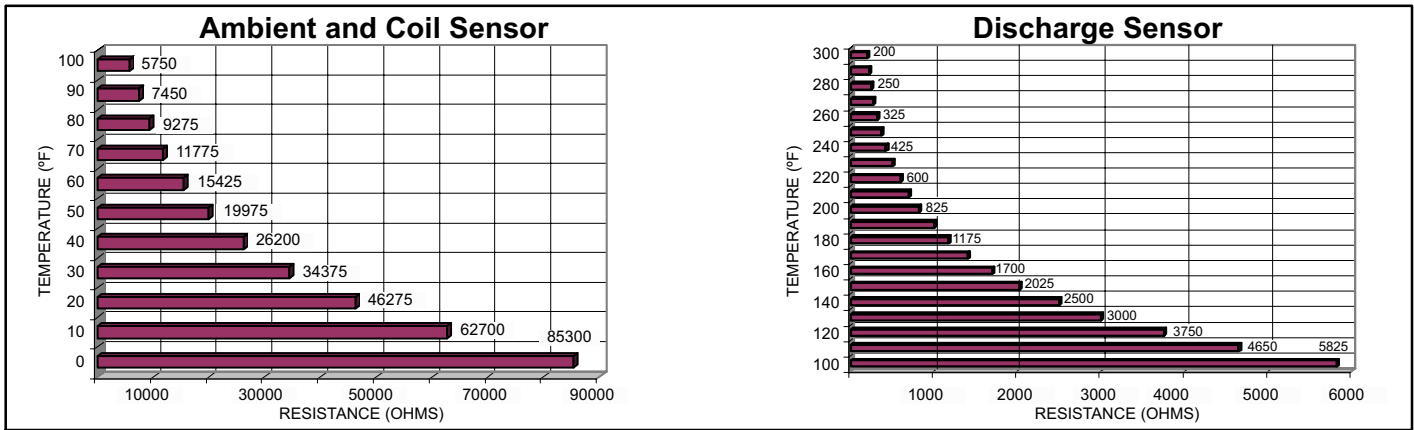

FIGURE 16

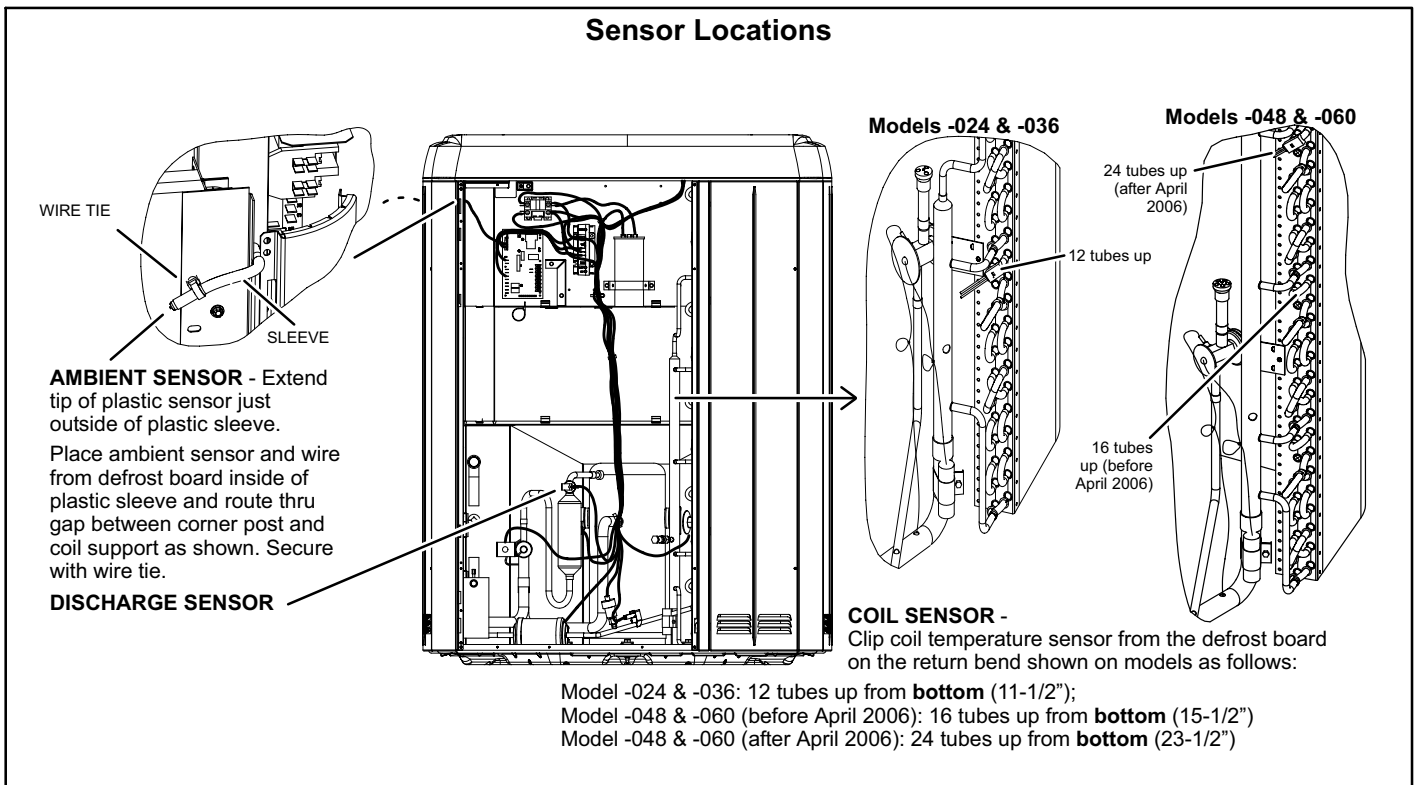

FIGURE 17

Ambient Sensor—The ambient sensor (shown in detail A, figure 17) considers outdoor temperatures below -35°F (-37°C) or above 120°F (48°C) as a problem. If the ambient sensor is detected as being open, shorted or out of the temperature range of the sensor, the board will not perform demand defrost operation. The board will revert to time/temperature defrost operation and will display the appropriate fault code. Heating and cooling operation will be allowed in this fault condition.

Coil Sensor—The coil temperature sensor (shown in detail B, figure 17) considers outdoor temperatures below -35°F (-37°C) or above 120°F (48°C) as a problem. If the coil temperature sensor is detected as being open, shorted or out of the temperature range of the sensor, the board will not perform demand or time/temperature defrost operation and will display the appropriate fault code. Heating and cooling operation will be allowed in this fault condition.

Discharge Line Sensor—If the discharge line temperature (shown in figure 17) exceeds a temperature of 285°F (140°C) during compressor operation, the board will de-energize the compressor contactor output (and the defrost output, if active). The compressor will remain off until the discharge temperature has dropped below 225°F (107°C) and the 5-minute anti-short cycle delay has been satisfied. This sensor has two fault and lockout codes:

- 3- If the board recognizes five high discharge line temperature faults during a single (Y1) compressor demand, it reverts to a lockout mode and displays the appropriate code. This code detects shorted sensor or high discharge temperatures. (Code on board is "Discharge Line Temperature Fault and Lockout").

- 4-. If the board recognizes five temperature sensor range faults during a single (Y1) compressor demand, it reverts to a lockout mode and displays the appropriate code. The board detects open sensor or out-of-temperature sensor range. This fault is detected by allowing the unit to run for 90 seconds before checking sensor resistance. If the sensor resistance is not within range after 90 seconds, the board will count one fault. After 5 faults, the board will lockout. (Code on board is "Discharge Sensor Fault and Lockout").

The discharge line sensor, which covers a range of 150°F (65°C) to 350°F (176°C), is designed to mount on a ½" refrigerant discharge line.

NOTE - Within a single room thermostat demand, if 5-strikes occur, the board will lockout the unit. Defrost board 24 volt power "R" must be cycled "OFF" or the "TEST" pins on board must be shorted between 1 to 2 seconds to reset the board.

Second-Stage Operation—If the board receives a call for second-stage compressor operation "Y2" in heating or cooling mode and the first-stage compressor output is active, the second-stage compressor solenoid output will be energized by the LSOM.

NOTE - The LSOM has a 5 second delay between Y2 being powered and the solenoid energizing.

If first-stage compressor output is active in heating mode and the outdoor ambient temperature is below the selected compressor lock-in temperature, the second-stage compressor solenoid output will be energized without the "Y2" room thermostat input. If the jumper is not connected to one of the temperature selection pins on P3 (40, 45, 50, 55°F), the default lock-in temperature of 40°F (4.5°C) will be used. The board de-energizes the second-stage compressor solenoid output immediately when the "Y2" signal is removed or the outdoor ambient temperature is 5°F above the selected compressor lock-in temperature, or the first-stage compressor output is de-energized for any reason.

Defrost Temperature Termination Shunt (Jumper) Pins—The defrost board selections are: 50, 70, 90, and 100°F (10, 21, 32 and 38°C). The shunt termination pin is factory set at 50°F (10°C). If the temperature shunt is not installed, the default termination temperature is 90°F (32°C).

Delay Mode

The defrost board has a field-selectable function to reduce occasional sounds that may occur while the unit is cycling in and out of the defrost mode. When a jumper is installed on the DELAY pins, the compressor will be cycled off for 30 seconds going in and out of the defrost mode. Units are shipped with jumper installed on DELAY pins.

NOTE - The 30 second off cycle is NOT functional when jumpering the TEST pins.

Operational Description

The defrost control board has three basic operational modes: normal, calibration, and defrost.

Normal Mode—The demand defrost board monitors the O line, to determine the system operating mode (heat/cool), outdoor ambient temperature, coil temperature (outdoor coil) and compressor run time to determine when a defrost cycle is required.

Calibration Mode—The board is considered uncalibrated when power is applied to the board, after cool mode operation, or if the coil temperature exceeds the termination temperature when it is in heat mode.

Calibration of the board occurs after a defrost cycle to ensure that there is no ice on the coil. During calibration, the temperature of both the coil and the ambient sensor are measured to establish the temperature differential which is required to allow a defrost cycle. See figure 19 for calibration mode sequence.

Defrost Mode—The following paragraphs provide a detailed description of the defrost system operation.

Detailed Defrost System Operation

Defrost Cycles—The demand defrost control board initiates a defrost cycle based on either frost detection or time.

Frost Detection—If the compressor runs longer than 34 minutes and the actual difference between the clear coil and frosted coil temperatures exceeds the maximum difference allowed by the control, a defrost cycle will be initiated.

Time—If 6 hours of heating mode compressor run time has elapsed since the last defrost cycle while the coil temperature remains below 35°F (2°C), the demand defrost control will initiate a defrost cycle.

Actuation—When the reversing valve is de-energized, the Y1 circuit is energized, and the coil temperature is below 35°F (2°C), the board logs the compressor run time. If the board is not calibrated, a defrost cycle will be initiated after 34 minutes of heating mode compressor run time. The control will attempt to self-calibrate after this (and all other) defrost cycle(s).

Calibration success depends on stable system temperatures during the 20-minute calibration period. If the board fails to calibrate, another defrost cycle will be initiated after 45 minutes (90 minutes for -1 to -4 boards) of heating mode compressor run time. Once the defrost board is calibrated, it initiates a demand defrost cycle when the difference between the clear coil and frosted coil temperatures exceeds the maximum difference allowed by the control OR after 6 hours of heating mode compressor run time has been logged since the last defrost cycle.

NOTE - If ambient or coil fault is detected, the board will not execute the “TEST” mode.

Termination—The defrost cycle ends when the coil temperature exceeds the termination temperature or after 14 minutes of defrost operation. If the defrost is terminated by the 14-minute timer, another defrost cycle will be initiated after 34 minutes of run time.

Test Mode—When Y1 is energized and 24V power is being applied to the board, a test cycle can be initiated by placing the termination temperature jumper across the “Test” pins for 2 to 5 seconds. If the jumper remains across the “Test” pins longer than 5 seconds, the control will ignore the test pins and revert to normal operation. The jumper will initiate one cycle per test.

Enter the “TEST” mode by placing a shunt (jumper) across the “TEST” pins on the board **after** power-up. (The “TEST” pins are ignored and the test function is locked out if the shunt is applied on the “TEST” pins before power-up). Board timings are reduced, the low-pressure switch and loss of charge detection fault is ignored and the board will clear any active lockout condition.

Each test pin shorting will result in one test event. For each “TEST” the shunt (jumper) must be removed for at least 1 second and reapplied. Refer to flow chart (figure 18) for “TEST” operation.

Note: The Y1 input must be active (ON) and the “O” room thermostat terminal into board must be inactive.

Defrost Board Diagnostics

See table 6 to determine defrost board operational conditions and to diagnose cause and solution to problems.

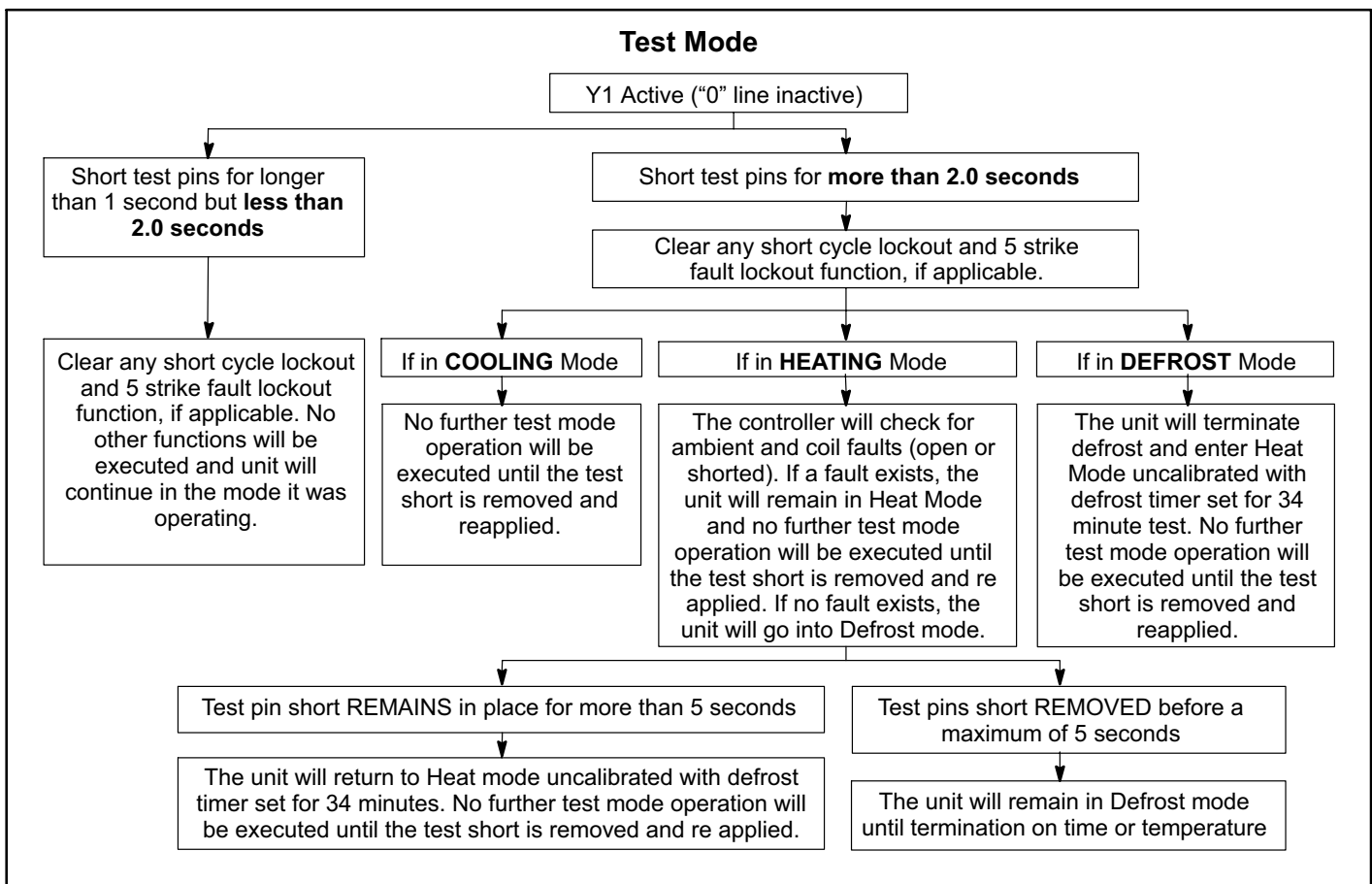

FIGURE 18

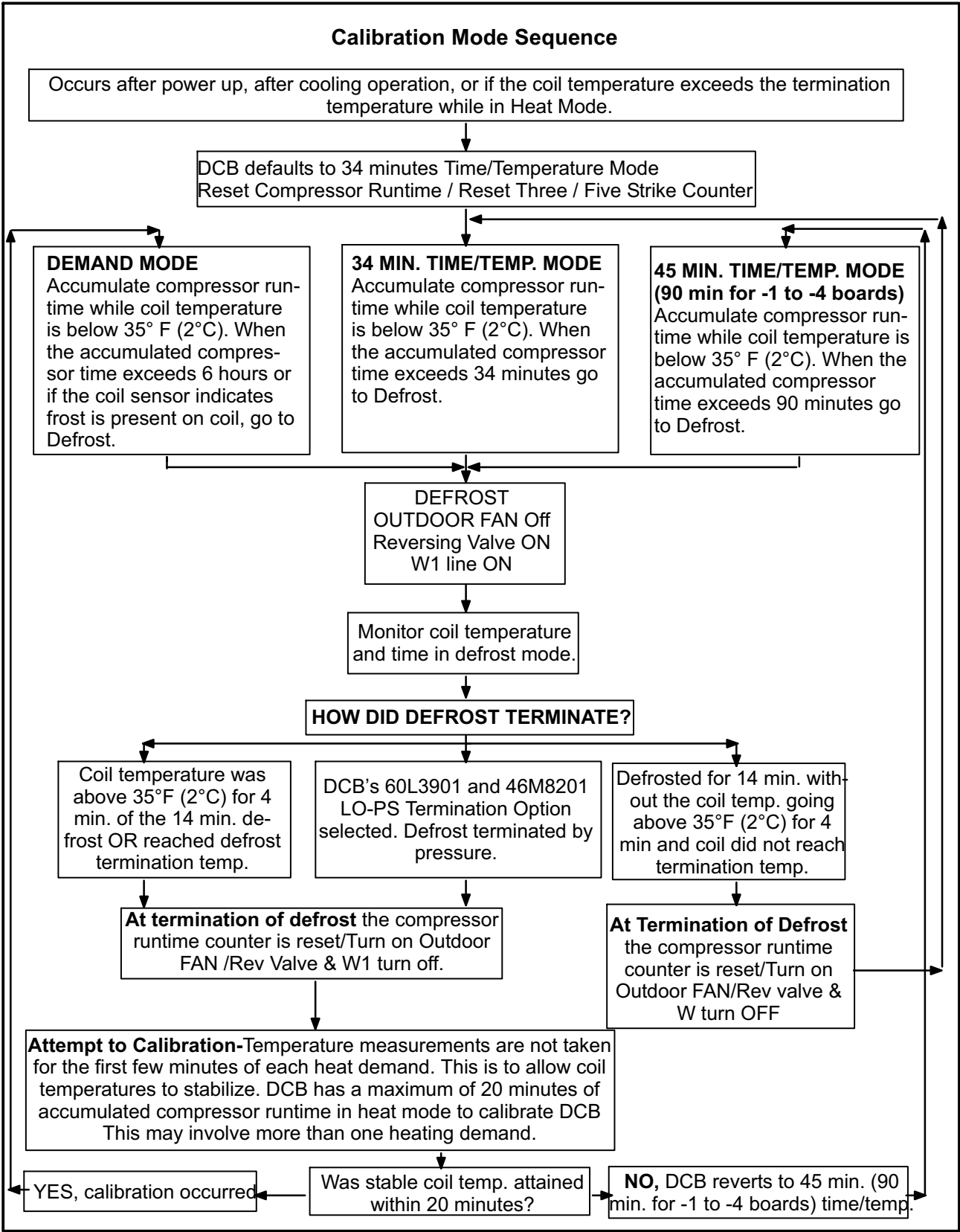

FIGURE 19

TABLE 6

Defrost Control Board Diagnostic LEDs				
DS2 Green	DS1 Red	Condition/Code	Possible Cause(s)	Solution
OFF	OFF	Power problem	No power (24V) to board terminals R & C or board failure.	¹ Check control transformer power (24V). ² If power is available to board and LED(s) do not light, replace board.
Simultaneous SLOW Flash		Normal operation	Unit operating normally or in standby mode.	None required.
Alternating SLOW Flash		5-minute anti-short cycle delay	Initial power up, safety trip, end of room thermostat demand.	None required (Jumper TEST pins to override)
Simultaneous FAST Flash		Ambient Sensor Problem	Sensor being detected open or shorted or out of temperature range. Board will revert to time/temperature defrost operation. (System will still heat or cool).	
Alternating FAST Flash		Coil Sensor Problem	Sensor being detected open or shorted or out of temperature range. Board will not perform demand or time/temperature defrost operation. (System will still heat or cool).	
ON	ON	Circuit Board Failure	Indicates that board has internal component failure. Cycle 24 volt power to board. If code does not clear, replace board.	
FAULT & LOCKOUT CODES (Each fault adds 1 strike to that code's counter; 5 strikes per code = LOCKOUT)				
OFF	SLOW Flash	Low Pressure Fault	¹ Restricted air flow over indoor or outdoor coil. ² Improper refrigerant charge in system. ³ Improper metering device installed or incorrect operation of metering device. ⁴ Incorrect or improper sensor location or connection to system.	¹ Remove any blockages or restrictions from coils and/or fans. Check indoor and outdoor fan motor for proper current draws. ² Check system charge using approach & sub-cooling temperatures. ³ Check system operating pressures and compare to unit charging charts. ⁴ Make sure all pressure switches and sensors have secure connections to system to prevent refrigerant leaks or errors in pressure and temperature measurements.
OFF	ON	Low Pressure LOCKOUT		
SLOW Flash	OFF	High Pressure Fault		
ON	OFF	High Pressure LOCKOUT		
SLOW Flash	ON	Discharge Line Temperature Fault	This code detects shorted sensor or high discharge temperatures. If the discharge line temperature exceeds a temperature of 285°F (140°C) during compressor operation, the board will de-energize the compressor contactor output (and the defrost output if active). The compressor will remain off until the discharge temperature has dropped below 225°F (107°C).	
FAST Flash	ON	Discharge Line Temperature LOCKOUT		
OFF	Fast Flash	Discharge Sensor Fault	The board detects open sensor or out of temperature sensor range. This fault is detected by allowing the unit to run for 90 seconds before checking sensor resistance. If the sensor resistance is not within range after 90 seconds, the board will count one fault. After 5 faults, the board will lockout.	
Fast Flash	OFF	Discharge Sensor LOCKOUT		

K-Crankcase Heater (HR1)

Compressors in all units are equipped with a 70 watt belly-band type crankcase heater. HR1 prevents liquid from accumulating in the compressor. HR1 is controlled by the crankcaseheater thermostat.

L- Crankcase heater Thermostat (S40)

Thermostat S40 controls the crankcase heater in all units. S40 is located on the liquid line. When liquid line temperature drops below 50° F the thermostat S40 closes energizing HR1. The thermostat will open, de-energizing HR1 once liquid line temperature reaches 70° F .

III-REFRIGERANT SYSTEM

⚠ IMPORTANT

The Clean Air Act of 1990 bans the intentional venting of (CFC's and HFC's) as of July 1, 1992. Approved methods of recovery, recycling or reclaiming must be followed. Fines and/or incarceration may be levied for noncompliance.

Field refrigerant piping consists of liquid and vapor lines from the outdoor unit (sweat connections). Use Lennox L15 series line sets as shown in table 7.

Separate liquid and suction service ports are provided at the service valves for connection of gauge manifold during charging procedure. Figure 20 shows XP19 refrigerant flow and gauge manifold connections.

TABLE 7

Model	Valve Field Size Connections		Recommended Line Set		
	Liquid Line	Vapor Line	Liquid Line	Vapor Line	L15 Line Sets
-024,-036	3/8 in. 10 mm	7/8 in. 22 mm	3/8 in. 10 mm	7/8 in. 19 mm	L15-65 15 ft. - 50 ft. 4.6 m - 15 m
-048	3/8 in. 10 mm	1-1/8 in. 29 mm	3/8 in. 10 mm	7/8 in. 22 mm	L15-65 15 ft. - 50 ft. 4.6 m - 15 m
-060	3/8 in. 10 mm	1-1/8 in. 29 mm	3/8 in. 10 mm	1-1/8 in. 29 mm	Field Fabricated

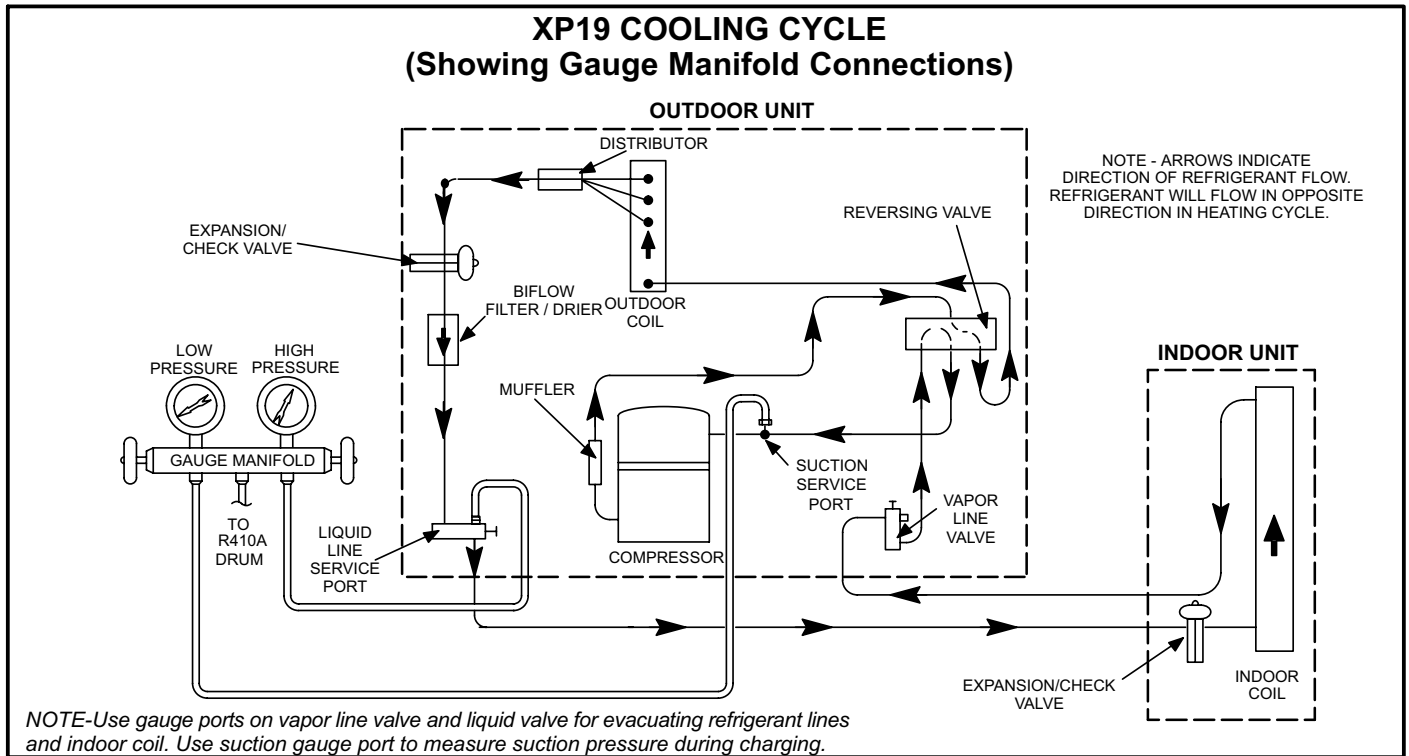

FIGURE 20

A-Service Valves

Access the liquid line and vapor line service valves (figures 21 and 22) and gauge ports are used for leak testing, evacuating, charging and checking charge. See table 8 for torque requirements.

Each valve is equipped with a service port which has a factory-installed Schrader valve. A service port cap protects the Schrader valve from contamination and serves as the primary leak seal.

TABLE 8

Part	Recommended Torque	
Service valve cap	8 ft.- lb.	11 NM
Sheet metal screws	16 in.- lb.	2 NM
Machine screws #10	28 in.- lb.	3 NM
Compressor bolts	90 in.- lb.	10 NM
Gauge port seal cap	8 ft.- lb.	11 NM

⚠ IMPORTANT

Service valves are closed to the outdoor unit and open to line set connections. Do not open the valves until refrigerant lines have been leak tested and evacuated. All precautions should be exercised to keep the system free from dirt, moisture and air.

To Access Schrader Port:

- 1 - Remove service port cap with an adjustable wrench.
- 2 - Connect gauge to the service port.
- 3 - When testing is complete, replace service port cap. Tighten finger tight, then an additional 1/6 turn.

To Open Service Valve:

- 1 - Remove stem cap with an adjustable wrench.
- 2 - Using service wrench and hex head extension, back the stem out counterclockwise as far as it will go.
NOTE - Use a 3/16" hex head extension for liquid line size.
- 3 - Replace stem cap and tighten it firmly. Tighten finger tight, then tighten an additional 1/6 turn.

To Close Service Valve:

- 1 - Remove stem cap with an adjustable wrench.
- 2 - Using service wrench and hex head extension, turn stem clockwise to seat valve. Tighten it firmly.
NOTE - Use a 3/16" hex head extension for liquid line size.
- 3 - Replace stem cap. Tighten finger tight, then tighten an additional 1/6 turn.

Vapor Line (Ball Type) Valve

Vapor line service valves function the same way as the other valves, the difference is in the construction. These valves are not rebuildable. If a valve has failed, you must replace it. A ball valve valve is illustrated in figure 22.

The ball valve is equipped with a service port with a factory-installed Schrader valve. A service port cap protects the Schrader valve from contamination and assures a leak-free seal.

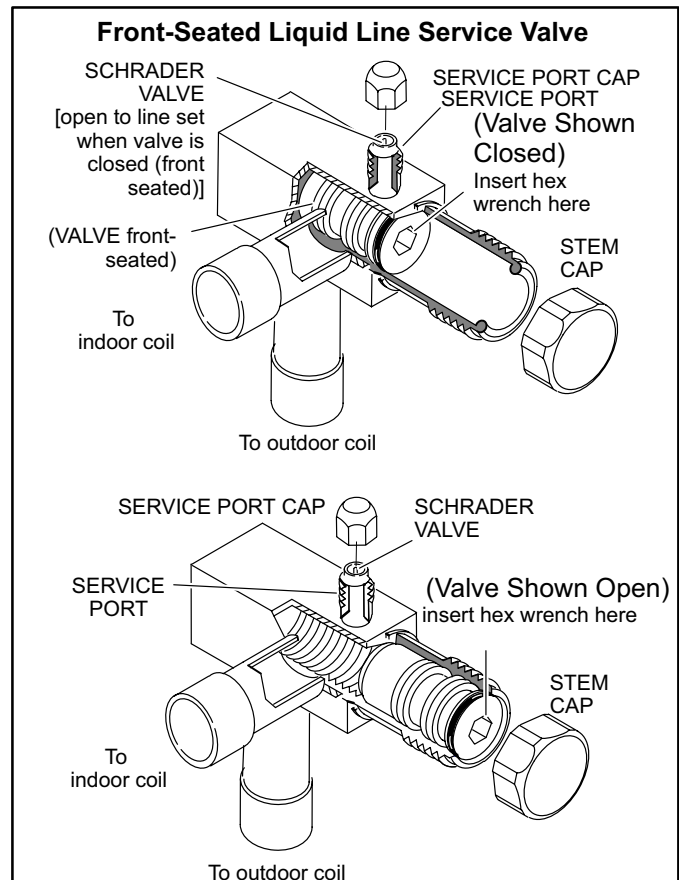

FIGURE 21

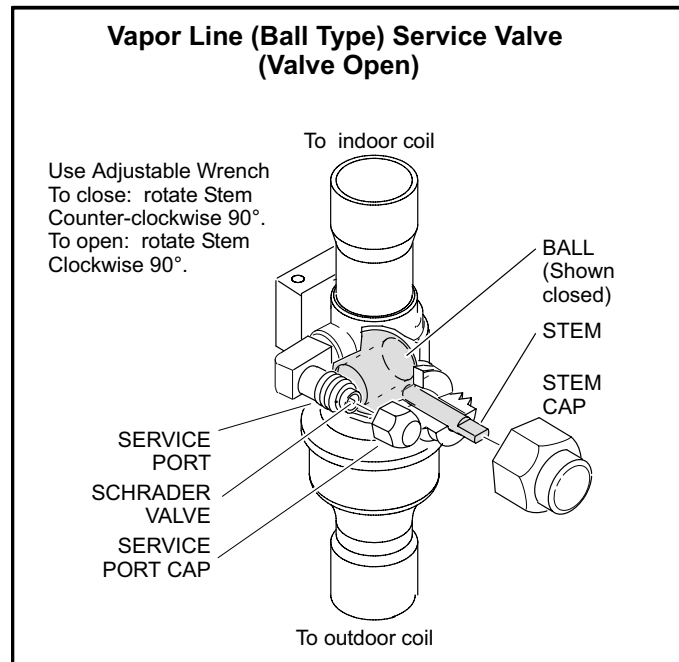

FIGURE 22

IV-CHARGING

Units are factory charged with the amount of R410A refrigerant indicated on the unit rating plate. This charge is based on a matching indoor coil and outdoor coil with 15 ft. (4.6m) line set. For varying lengths of line set, refer to table 9 for refrigerant charge adjustment.

TABLE 9

Liquid Line Set Diameter	Ozs. per 5 ft. (grams per 1.5m) adjust from 15 ft. (4.6m) line set*
3/8 in. (9.5mm)	3 ounces per 5 feet (85g per 1.5m)

*If line length is greater than 15 ft. (4.6m), add this amount. If line length is less than 15 ft. (4.6), subtract this amount.

A-Leak Testing

After the line set has been connected to the indoor and outdoor units, the line set connections and indoor unit must be checked for leaks.

WARNING

Refrigerant can be harmful if inhaled. Refrigerant must be used and recovered responsibly. Failure to follow this warning can lead to injury or death.

WARNING

Fire, Explosion and Personal Safety Hazard. Failure to follow this warning could result in damage, personal injury or death. Never use oxygen to pressurize or purge refrigeration lines. Oxygen when exposed to a spark or open flame can cause damage by fire and or an explosion, that could result in personal injury or death.

WARNING

Danger of explosion: Can cause equipment damage, injury or death. When using a high pressure gas such as dry nitrogen to pressurize a refrigeration or air conditioning system, use a regulator that can control the pressure down to 1 or 2 psig (6.9 to 13.8 kPa).

Using an Electronic Leak Detector

- 1 - Connect a cylinder of R410A to the center port of the manifold gauge set.
- 2 - With both manifold valves closed, open the valve on the R410A cylinder (vapor only).
- 3 - Open the high pressure side of the manifold to allow the R410A into the line set and indoor unit. Weigh in a trace amount of R410A. [A trace amount is a maximum of 2 ounces (57 g) or 3 pounds (31 kPa) pressure.] Close the valve on the R410A cylinder and the valve on the high pressure side of the manifold gauge set. Disconnect the R410A cylinder.
- 4 - Connect a cylinder of nitrogen with a pressure regulating valve to the center port of the manifold gauge set.

- 5 - Connect the manifold gauge set high pressure hose to the vapor valve service port. (Normally, the high pressure hose is connected to the liquid line port; however, connecting it to the vapor port better protects the manifold gauge set from high pressure damage.)
- 6 - Adjust the nitrogen pressure to 150 psig (1034 kPa). Open the valve on the high side of the manifold gauge set which will pressurize line set and indoor unit.
- 7 - After a few minutes, open a refrigerant port to ensure the refrigerant you added is adequate to be detected. (Amounts of refrigerant will vary with line lengths.) Check all joints for leaks. Purge nitrogen and R410A mixture. Correct any leaks and recheck.

IMPORTANT

Leak detector must be capable of sensing HFC refrigerant.

B-Evacuating

Evacuating the system of noncondensables is critical for proper operation of the unit. Noncondensables are defined as any gas that will not condense under temperatures and pressures present during operation of an air conditioning system. Noncondensables and water vapor combine with refrigerant to produce substances that corrode copper piping and compressor parts.

IMPORTANT

Use a thermocouple or thermistor electronic vacuum gauge that is calibrated in microns. Use an instrument that reads from 50 microns to at least 23,000 microns.

- 1 - Connect the manifold gauge set to the service valve ports as follows:
 - low pressure gauge to vapor line service valve
 - high pressure gauge to liquid line service valve
- 2 - Connect micron gauge.
- 3 - Connect the vacuum pump (with vacuum gauge) to the center port of the manifold gauge set.
- 4 - Open both manifold valves and start vacuum pump.
- 5 - Evacuate the line set and indoor unit to an **absolute pressure** of 23,000 microns (29.01 inches of mercury). During the early stages of evacuation, it is desirable to close the manifold gauge valve at least once to determine if there is a rapid rise in **absolute pressure**. A rapid rise in pressure indicates a relatively large leak. If this occurs, repeat the leak testing procedure.
NOTE - The term absolute pressure means the total actual pressure within a given volume or system, above the absolute zero of pressure. Absolute pressure in a vacuum is equal to atmospheric pressure minus vacuum pressure.
- 6 - When the absolute pressure reaches 23,000 microns (29.01 inches of mercury), close the manifold gauge valves, turn off the vacuum pump and disconnect the manifold gauge center port hose from vacuum pump.

Attach the manifold center port hose to a nitrogen cylinder with pressure regulator set to 150 psig (1034 kPa) and purge the hose. Open the manifold gauge valves to break the vacuum in the line set and indoor unit. Close the manifold gauge valves.

⚠️ WARNING

Danger of Equipment Damage. Avoid deep vacuum operation. Do not use compressors to evacuate a system. Extremely low vacuums can cause internal arcing and compressor failure. Damage caused by deep vacuum operation will void warranty.

- 7 - Shut off the nitrogen cylinder and remove the manifold gauge hose from the cylinder. Open the manifold gauge valves to release the nitrogen from the line set and indoor unit.
- 8 - Reconnect the manifold gauge to the vacuum pump, turn the pump on, and continue to evacuate the line set and indoor unit until the absolute pressure does not rise above 500 microns (29.9 inches of mercury) within a 20-minute period after shutting off the vacuum pump and closing the manifold gauge valves.
- 9 - When the absolute pressure requirement above has been met, disconnect the manifold hose from the vacuum pump and connect it to an upright cylinder of R410A refrigerant. Open the manifold gauge valves to break the vacuum from 1 to 2 psig positive pressure in the line set and indoor unit. Close manifold gauge valves and shut off the R410A cylinder and remove the manifold gauge set.

C-Charging

This system is charged with R410A refrigerant which operates at much higher pressures than R22. The check/expansion valve provided with the unit is approved for use with R410A. Do not replace it with a valve designed for use with R22. This unit is NOT approved for use with coils which include metering orifices or capillary tubes.

Processing Procedure

The unit is factory-charged with the amount of R410A refrigerant indicated on the unit rating plate. This charge is based on a matching indoor coil and outdoor coil with a 15 foot (4.6m) line set. For varying lengths of line set, refer to table 9 for refrigerant charge adjustment. .

⚠️ IMPORTANT

Mineral oils are not compatible with R410A. If oil must be added, it must be a polyol ester oil.

It is desirable to charge the system in the cooling cycle if weather conditions permit. However, if the unit must be charged in the heating season, one of the following procedures must be followed to ensure proper system charge.

Weighing in the Charge TXV Systems – Outdoor Temp. < 65°F (18°C)

If the system is void of refrigerant, or if the outdoor ambient temperature is cool, the refrigerant charge should be weighed into the unit. Do this after any leaks have been repaired.

- 1 - Recover the refrigerant from the unit.
- 2 - Conduct a leak check, then evacuate as previously outlined.
- 3 - Weigh in the unit nameplate charge.

If weighing facilities are not available or if you are charging the unit during warm weather, follow one of the other procedures outlined below.

Subcooling Method Outdoor Temp. < 65°F (18°C)

When the outdoor ambient temperature is below 65°F (18°C), use the subcooling method to charge the unit. It may be necessary to restrict the air flow through the outdoor coil to achieve pressures in the 325-375 psig (2240-2585 kPa) range. These higher pressures are necessary for checking the charge. Block equal sections of air intake panels and move obstructions sideways until the liquid pressure is in the 325-375 psig (2240-2585 kPa) range. Figure 23 shows a four sided unit for example..

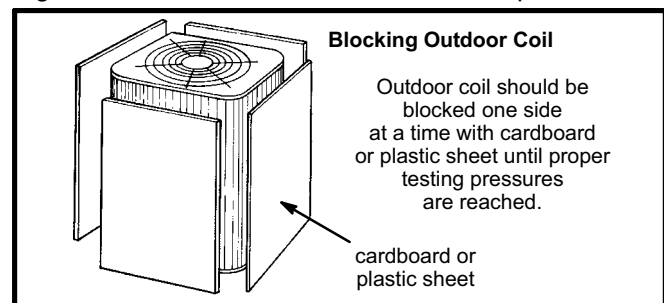

FIGURE 23

- 1 - With the manifold gauge hose still on the liquid service port and the unit operating stably, use a digital thermometer to record the liquid line temperature.
- 2 - At the same time, record the liquid line pressure reading.
- 3 - Use a temperature/pressure chart for R410A to determine the saturation temperature for the liquid line pressure reading. See table 14.
- 4 - Subtract the liquid line temperature from the saturation temperature (according to the chart) to determine subcooling. **(Saturation temperature - Liquid line temperature = Subcooling)**
- 5 - Compare the subcooling value with those in table 10. If subcooling is greater than shown, recover some refrigerant. If subcooling is less than shown, add some refrigerant. Be aware of the R410A refrigerant cylinder. It will be light maroon-colored. Refrigerant should be added through the vapor line valve in the liquid state. **Some R410A cylinders are equipped with a dip tube that allows you to draw liquid refrigerant from the bottom of the cylinder without turning the cylinder upside-down. The cylinder will be marked if it is equipped with a dip tube.**

TABLE 10
2nd stage High Capacity

Subcooling Values for Charging	
Model	Second-Stage (High Capacity) Subcooling Values - Conversion Temp. - Liquid Line Temp. °F (°C)
XP19-024	8.0 ± 1 (4.4 ± .5)
XP19-036	6.0 ± 1 (3.3 ± .5)
XP19-048	6.0 ± 1 (3.3 ± .5)
XP19-060	6.0 ± 1 (3.3 ± .5)

Charging Using Normal Operating Pressures and the Approach Method
Outdoor Temp. ≥ 65°F (18°C)

The following procedure is intended as a general guide and is for use on expansion valve systems only. For best results, indoor temperature should be 70°F (21°C) to 80°F (26°C). Monitor system pressures while charging.

- 1 - Record outdoor ambient temperature using a digital thermometer.
- 2 - Attach high pressure gauge set and operate unit for several minutes to allow system pressures to stabilize.
- 3 - Compare stabilized pressures with those provided in tables 12 and 13, "Normal Operating Pressures." Minor variations in these pressures may be expected due to differences in installations. Significant differences could mean that the system is not properly charged or that a problem exists with some component in the system. Pressures higher than those listed indicate that the system is overcharged. Pressures lower than those listed indicate that the system is undercharged. Verify adjusted charge using the approach method.

Approach Method

- 4 - Use the same digital thermometer used to check outdoor ambient temperature to check liquid line temperature. Verify the unit charge using the approach method.
- 5 - The difference between the ambient and liquid temperatures should match values given in table 11. If the values don't agree with the those in table 11, add refrigerant to lower the approach temperature or recover refrigerant from the system to increase the approach temperature.

TABLE 11
2nd Stage High Capacity

Approach Values for Charging	
Model	Second-Stage (High Capacity) Approach Temp. - Liquid Line Temp. - Outdoor Ambient °F (°C)
XP19-024	7.0 ± 1 (3.9 ± .5)
XP19-036	9.0 ± 1 (5.0 ± .5)
XP19-048	7.0 ± 1 (3.9 ± .5)
XP19-060	9.0 ± 1 (5.0 ± .5)

! IMPORTANT

Use table 12 and table 13 as a general guide when performing maintenance checks. This is not a procedure for charging the unit (Refer to Charging/Checking Charge section). Minor variations in these pressures may be expected due to differences in installations. Significant differences could mean that the system is not properly charged or that a problem exists with some component in the system.

TABLE 12

Normal Operating Pressure (Heating Operation) - Liquid ±10 & Vapor ±5 PSIG*								
Outdoor Coil Entering Air Temperature °F (°C)	XP19-024		XP19-036		XP19-048		XP19-060	
	LQ-UID	VA-PO R	LQ-UID	VA-PO R	LQ-UID	VA-PO R	LQ-UID	VA-PO R
First Stage (Low Capacity)								
40 (4.4)	302	99	301	95	324	93	342	90
50 (10)	318	121	317	114	351	117	388	112
Second Stage (High Capacity)								
20 (-7.0)	280	67	280	57	337	74	346	60
30 (-1.0)	297	82	298	75	342	76	365	71
40 (4.4)	317	99	313	89	352	89	390	84
50 (10)	330	118	328	87	379	107	402	104

**These are typical pressures only. Indoor match up, indoor air quality, and indoor load will cause the pressures to vary.*

TABLE 13

Normal Operating Pressure (Cooling Operation) - Liquid ±10 & Vapor ±5 PSIG*								
Outdoor Coil Entering Air Temperature °F (°C)	XP19-024		XP19-036		XP19-048		XP19-060	
	LQ-UID	VA-PO R	LQ-UID	VA-PO R	LQ-UID	VA-PO R	LQ-UID	VA-PO R
First Stage (Low Capacity)								
65 (18.3)	226	152	230	148	210	136	234	135
75 (23.9)	262	151	267	150	242	138	274	137
85 (29.4)	304	152	309	153	286	140	314	142
95 (35.0)	351	155	355	155	328	142	361	147
105 (40.6)	400	158	404	157	374	144	413	147
115 (49.0)	454	161	460	159	426	146	470	149
Second Stage (High Capacity)								
65 (18.3)	228	146	236	144	227	114	237	131
75 (23.9)	267	148	275	145	265	123	276	133
85 (29.4)	309	149	318	148	306	132	320	135
95 (35.0)	358	151	365	150	348	138	369	138
105 (40.6)	410	152	416	153	397	141	423	140
115 (49.0)	465	154	473	155	453	143	482	144

**These are typical pressures only. Indoor match up, indoor air quality, and indoor load will cause the pressures to vary.*

Table 14
R410A Temperature/Pressure Chart

Temperature °F	Pressure Psig	Temperature °F	Pressure Psig	Temperature °F	Pressure Psig	Temperature °F	Pressure Psig
32	100.8	63	178.5	94	290.8	125	445.9
33	102.9	64	181.6	95	295.1	126	451.8
34	105.0	65	184.3	96	299.4	127	457.6
35	107.1	66	187.7	97	303.8	128	463.5
36	109.2	67	190.9	98	308.2	129	469.5
37	111.4	68	194.1	99	312.7	130	475.6
38	113.6	69	197.3	100	317.2	131	481.6
39	115.8	70	200.6	101	321.8	132	487.8
40	118.0	71	203.9	102	326.4	133	494.0
41	120.3	72	207.2	103	331.0	134	500.2
42	122.6	73	210.6	104	335.7	135	506.5
43	125.0	74	214.0	105	340.5	136	512.9
44	127.3	75	217.4	106	345.3	137	519.3
45	129.7	76	220.9	107	350.1	138	525.8
46	132.2	77	224.4	108	355.0	139	532.4
47	134.6	78	228.0	109	360.0	140	539.0
48	137.1	79	231.6	110	365.0	141	545.6
49	139.6	80	235.3	111	370.0	142	552.3
50	142.2	81	239.0	112	375.1	143	559.1
51	144.8	82	242.7	113	380.2	144	565.9
52	147.4	83	246.5	114	385.4	145	572.8
53	150.1	84	250.3	115	390.7	146	579.8
54	152.8	85	254.1	116	396.0	147	586.8
55	155.5	86	258.0	117	401.3	148	593.8
56	158.2	87	262.0	118	406.7	149	601.0
57	161.0	88	266.0	119	412.2	150	608.1
58	163.9	89	270.0	120	417.7	151	615.4
59	166.7	90	274.1	121	423.2	152	622.7
60	169.6	91	278.2	122	428.8	153	630.1
61	172.6	92	282.3	123	434.5	154	637.5
62	195.5	93	286.5	124	440.2	155	645.0

V-SERVICE AND RECOVERY

⚠ WARNING

Polyol ester (POE) oils used with R410A refrigerant absorb moisture very quickly. It is very important that the refrigerant system be kept closed as much as possible. DO NOT remove line set caps or service valve stub caps until you are ready to make connections.

IMPORTANT - Use recovery machine rated for R410 refrigerant.

If the XP19 system must be opened for any kind of service, such as compressor or filter drier replacement, you must take extra precautions to prevent moisture from entering the system. The following steps will help to minimize the amount of moisture that enters the system during recovery of R410A.

- 1 - Use a regulator-equipped nitrogen cylinder to break the system vacuum. Do not exceed 5 psi. The dry nitrogen will fill the system, and will help purge any moisture.
- 2 - Remove the faulty component and quickly seal the system (using tape or some other means) to prevent additional moisture from entering the system.
- 3 - Do not remove the tape until you are ready to install new component. Quickly install the replacement component.
- 4 - Evacuate the system to remove any moisture and other non-condensables.

The XP19 system MUST be checked for moisture any time the sealed system is opened.

Any moisture not absorbed by the polyol ester oil can be removed by triple evacuation. Moisture that has been absorbed by the compressor oil can be removed by replacing the filter drier.

⚠ IMPORTANT

Evacuation of system only will not remove moisture from oil. Filter drier must be replaced to eliminate moisture from POE oil.

VI-MAINTENANCE

⚠ WARNING



Electric shock hazard. Can cause injury or death. Before attempting to perform any service or maintenance, turn the electrical power to unit OFF at disconnect switch(es). Unit may have multiple power supplies.

Maintenance and service must be performed by a qualified installer or service agency. At the beginning of each cooling or heating season, the system should be checked as follows:

Outdoor Unit

- 1 - Clean and inspect outdoor coil (may be flushed with a water hose). Ensure power is off before cleaning.
- 2 - Outdoor unit fan motor is prelubricated and sealed. No further lubrication is needed.
- 3 - Visually inspect all connecting lines, joints and coils for evidence of oil leaks.
- 4 - Check all wiring for loose connections.
- 5 - Check for correct voltage at unit (unit operating).
- 6 - Check amp-draw on outdoor fan motor and compressor (high and low capacity).
- 7 - Inspect drain holes in coil compartment base and clean if necessary.

NOTE - If owner complains of insufficient cooling, the unit should be gauged and refrigerant charge checked. Refer to section on refrigerant charging in this instruction.

VII-BRAZING

Before brazing remove access panels and any piping panels to avoid burning off paint. Be aware of any components ie, service valves, reversing valve, pressure switches that may be damaged due to brazing heat.

When making line set connections, use 1 to 2 psig dry nitrogen to purge the refrigerant piping. This will help to prevent oxidation into the system.

⚠ WARNING

Danger of explosion: Can cause equipment damage, injury or death. When using a high pressure gas such as dry nitrogen to pressurize a refrigeration or air conditioning system, use a regulator that can control the pressure down to 1 or 2 psig (6.9 to 13.8 kPa).

- 1 - .Cut ends of copper square (free from nicks or dents). Deburr the ends. The pipe must remain round, do not pinch end of line.
- 2 - Wrap wet rag around any components that may be damaged.
- 3 - Use silver alloy brazing rods (5 or 6 percent minimum silver alloy for copper to copper brazing or 45 percent silver alloy for copper to brass or copper to steel brazing) which are rated for use with R-22 and R-410A refrigerant.
- 4 - After brazing quench the joints with a wet rag to prevent possible heat damage to any components.

VIII-DIAGRAM / OPERATING SEQUENCE

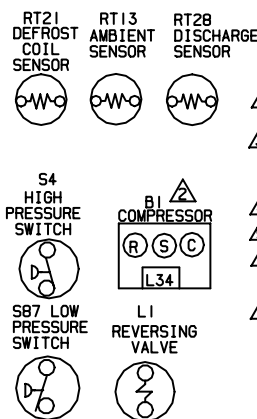
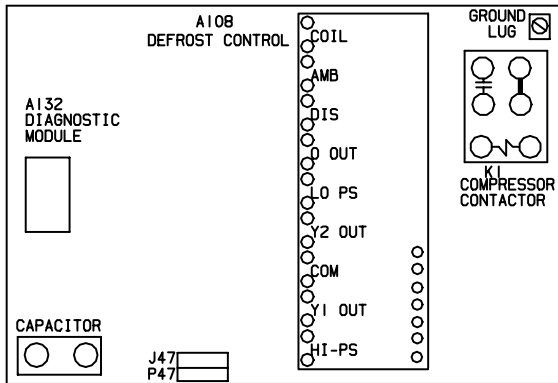

⚠ NOTE-
FOR USE WITH COPPER CONDUCTORS ONLY. REFER TO UNIT RATING PLATE FOR MINIMUM CIRCUIT AMPACITY AND MAXIMUM OVER-CURRENT PROTECTION SIZE.

⚠ REFER TO COMPRESSOR IN UNIT FOR ACTUAL TERMINAL ARRANGEMENT.

⚠ WARNING-
ELECTRIC SHOCK HAZARD, CAN CAUSE INJURY OR DEATH. UNIT MUST BE GROUNDED IN ACCORDANCE WITH NATIONAL AND LOCAL CODES.

⚠ REMOVE JUMPER FOR TWO STAGE COOL

⚠ RT14 SENSOR, OUTDOOR TEMP (OPTIONAL)

⚠ L34 SOLENOID IS LOCATED IN COMPRESSOR, COIL IS 24VDC, DO NOT CONNECT 24VAC TO COIL TERMINALS

⚠ 024 UNITS COME FACTORY WIRED FOR LOW OUTDOOR FAN SPEED ONLY, HIGH SPEED Y2, (BLUE WIRE) IS NOT CONNECTED

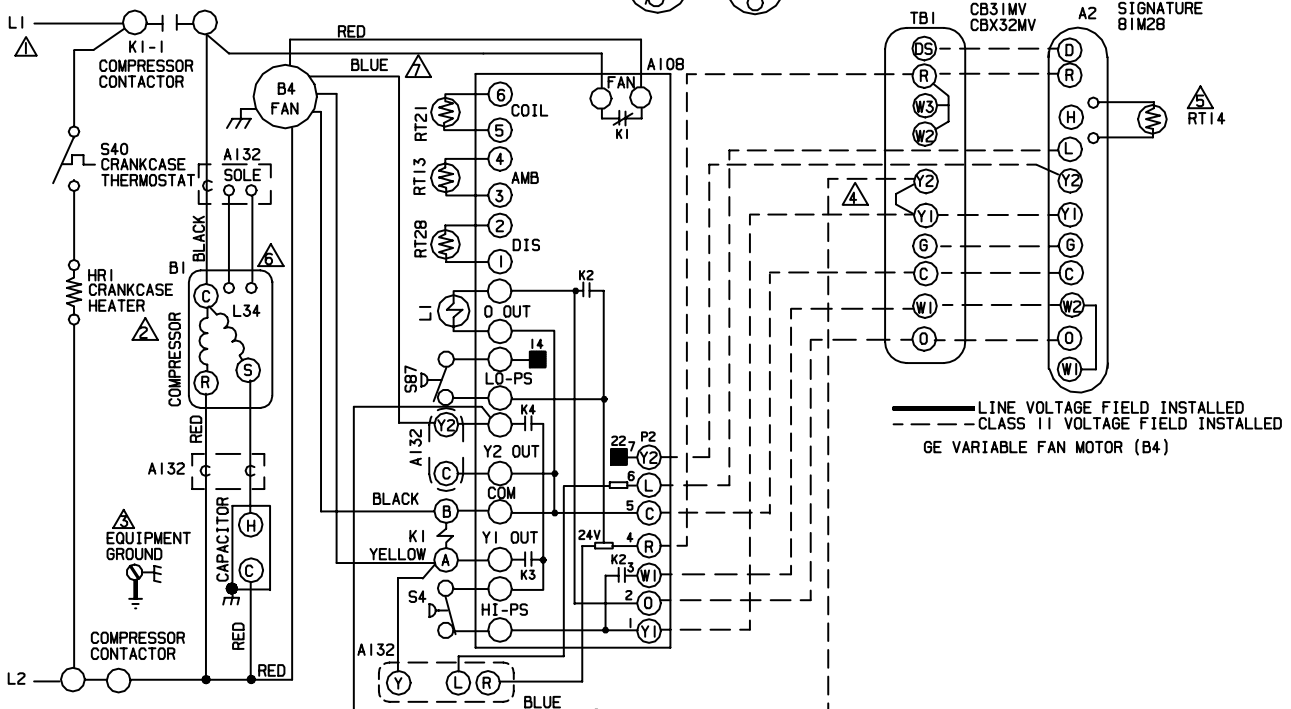

— LINE VOLTAGE FIELD INSTALLED
 - - - CLASS II VOLTAGE FIELD INSTALLED
 GE VARIABLE FAN MOTOR (B4)

LENNOX HEAT PUMP OUTDOOR UNITS	
XP19-024-230	XP19-048-230
XP19-036-230	XP19-060-230
0106	Supersedes Form No. 534, 863W
	New Form No. 535, 325W

©2008 Lennox Industries Inc. Litho U.S.A.

Sequence of Operation XP19-024/060

First Stage Cool (low capacity)

Transformer from indoor unit supplies 24VAC power to the thermostat and outdoor unit controls.

- 1- Internal wiring energizes terminal O by cooling mode selection, energizing the reversing valve. Cooling demand initiates at Y1 in the thermostat.
- 2- 24VAC passes through high pressure switch S4 and discharge thermostat switch S5 energizing compressor contactor K1.
- 3- K1-1 N.O. closes energizing compressor B1 and outdoor fan motor B4.
- 4- Solenoid L34 is NOT energized. The slider ring remains open limiting compressor to low capacity.

Second Stage Cool (high capacity)

- 5- Second stage thermostat demand sends voltage to the LSOM. After a 5 second delay the LSOM converts the AC voltage to DC voltage and energizes solenoid L34. L34 then closes the slider ring, allowing the compressor to operate at high capacity. Variable speed outdoor fan operates on high speed (blue tap).

Heating

A – Low Capacity

- 1 - Room thermostat in heating mode. Room thermostat outputs Y1 signal to the defrost board in the heat pump and to the indoor air handler.
- 2 - The defrost board checks for open low or high-pressure switches and proper coil, ambient and discharge sensor readings. If checks show no issues, the defrost board sends 24 volts through Y1 OUT signal to the K1 compressor contactor coil, the Y1 terminal on the diagnostic module (A132) and the yellow wire to the outdoor fan motor.
- 3 - K1-1 closes, energizing the compressor and puts 240 volts into the outdoor fan motor through the normally closed fan relay contacts on the defrost board.
- 4 - The compressor will run on low capacity and the 24volt input on the yellow wire to the outdoor fan motor will allow it to run on low speed.

B – High Capacity (Ambient temperature above defrost board Y2 lock-in temperature)

- 1 - Room thermostat in heating mode. Room thermostat outputs Y1 and Y2 (if applicable to that room thermostat) signal to the defrost board in the heat pump and to the indoor unit.
- 2 - The defrost board checks for open low or high-pressure switches and proper coil, ambient and discharge sensor readings. If checks show no issues, the defrost board sends 24 volts through Y1 OUT signal to the K1 compressor contactor coil, the Y1 terminal on the diagnostic module (A132) and the yellow wire to the outdoor fan motor.
- 3 - The defrost board sends 24 volts through Y2 OUT signal to the Y2 terminal on the diagnostic module (A132) and the blue wire to the outdoor fan motor.
- 4 - K1-1 closes, energizing the compressor and puts 240 volts into the outdoor fan motor through the normally closed fan relay contacts on the defrost board.

- 5 - The compressor will run on low capacity for 5 seconds. The diagnostic module (LSOM) will confirm low stage operation and then output a 24volt DC signal to the L34 internal high capacity solenoid valve in the compressor. Once the solenoid is energized, the diagnostic module will continue pulsing 6 to 18 volt DC signal to the solenoid to keep it energized during the Y2 room thermostat demand.
- 6 - The 24volt inputs to the yellow and blue wires of the outdoor fan motor will provide high-speed operation.

B – High Capacity (Ambient temperature below defrost board Y2 lock-in temperature)

- 1 - Room thermostat in heating mode. Room thermostat outputs Y1 signal to the defrost board in the heat pump and to the indoor unit.
- 2 - The defrost board checks for open low or high-pressure switches and proper coil, ambient and discharge sensor readings. If checks show no issues, the defrost board sends 24 volts through Y1 OUT signal to the K1 compressor contactor coil, the Y1 terminal on the diagnostic module (A132) and the yellow wire to the outdoor fan motor.
- 3 - The defrost board **Y2 locks in** sends 24 volts through Y2 OUT signal to the Y2 terminal on the diagnostic module (A132) and the blue wire to the outdoor fan motor.
- 4 - K1-1 closes, energizing the compressor and puts 240 volts into the outdoor fan motor through the normally closed fan relay contacts on the defrost board.
- 5 - The compressor will run on low capacity for 5 seconds. The diagnostic module (LSOM) will confirm low stage operation and then output a 24volt DC signal to the L34 internal high capacity solenoid valve in the compressor. Once the solenoid is energized, the diagnostic module will continue pulsing 6 to 18 volt DC signal to the solenoid to keep it energized during the Y2 operation.
- 6 - The 24volt inputs to the yellow and blue wires of the outdoor fan motor will provide high-speed operation.

Defrost Mode

When a defrost cycle is initiated, the control energizes the reversing valve solenoid and turns off the condenser fan. The control will also put 24VAC on the "W1" (auxiliary heat) line. The unit will stay in this mode until either the coil sensor temperature is above the selected termination temperature, the defrost time of 14 minutes has been completed, or the room thermostat demand cycle has been satisfied. (If the temperature select shunt is not installed, the default termination temperature will be 90°F.) If the room thermostat demand cycle terminates the cycle, the defrost cycle will be held until the next room thermostat demand cycle. If the coil sensor temperature is still below the selected termination temperature, the control will continue the defrost cycle until the cycle is terminated in one of the methods mentioned above. If a defrost is terminated by time and the coil temperature did not remain above 35°F (2°C) for 4 minutes the control will go to the 34-minute Time/Temperature mode.