

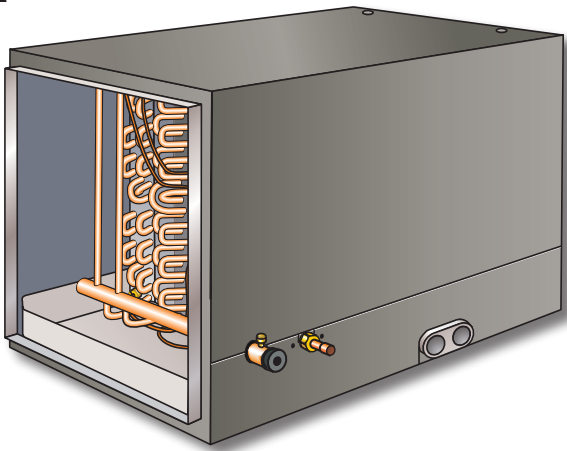

Horizontal

ENGINEERING DATA

Bulletin No. 210281
September 2010
Supersedes April 2007



1.5 to 5 Tons

MODEL NUMBER IDENTIFICATION

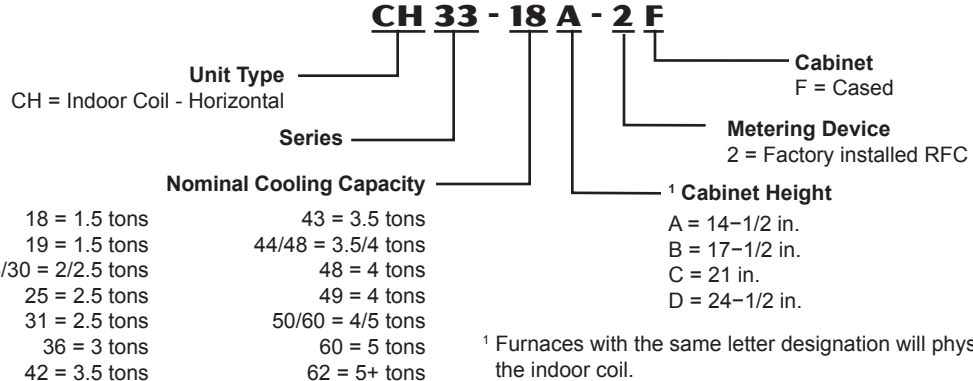

1 Furnaces with the same letter designation will physically match the indoor coil.

FEATURES

CONTENTS

Table listing contents: Air Resistance (3), Dimensions (4), Features (1), Model Number Identification (1), Specifications (2)

WARRANTY

All covered components limited warranty for five years in residential applications, one year warranty in non-residential applications. Refer to Lennox Equipment Limited Warranty certificate included with equipment for details.

APPLICATIONS

Lennox designed horizontal indoor coils can easily be installed with most Lennox horizontal furnaces. Applicable to expansion valve or RFCIV systems. Expansion valve systems require optional field installed kit. See bulletins in section Air Conditioners for cooling capacities. See bulletins in section Heat Pump Outdoor Units for cooling and heating capacities.

TESTED

Tested with matching air conditioners and heat pump units. Rated in accordance with AHRI Standard 210/240 conditions and DOE test procedures. Air resistance tests from Lennox Laboratory air test chamber.

CABINET

Cabinets insulated with thick fiberglass insulation. Heavy gauge, pre-painted galvanized steel. Flanges furnished for ease of duct connection. Engaging holes furnished on cabinet for alignment with furnace. Removable panels provide access to coil. Refrigerant lines extend outside of cabinet for easy connection.

Furnace Match-Up

All cased coils exactly match corresponding furnaces with same letter designation in model number. No adaptor required. Engaging holes furnished on cabinet for alignment.

FEATURES

REFRIGERANT SYSTEM

Coil Construction

Durable copper tubing.

Ripple-edged aluminum fins.

Lanced fins provide maximum exposure of fin surface to air stream.

Rifled tubing provides superior refrigerant flow.

Non-corrosive drain pan with dual drain connections.

Sweat connections on both liquid and suction lines.

Liquid line seal nut section furnished for installation of expansion valve.

RFCIV metering device factory installed in liquid line.

High pressure testing ensures leakproof construction.

Refrigerant Control Choice

All models applicable to Lennox RFCIV refrigerant metering system when matched with specific air conditioners.

See Air Conditioners bulletins for applications.

Optional expansion valve or check/expansion valve is required in most applications and must be ordered extra.

Refrigerant Flow Control IV

RFCIV accurately meters refrigerant in system.

Refrigerant control is accomplished by exact sizing of refrigerant metering orifice.

Principle of Lennox RFCIV system involves matching indoor coil with proper bore size of orifice in metering device.

RFCIV system equalizes pressure shortly after compressor stops, unit starts unloaded, eliminating need for additional controls.

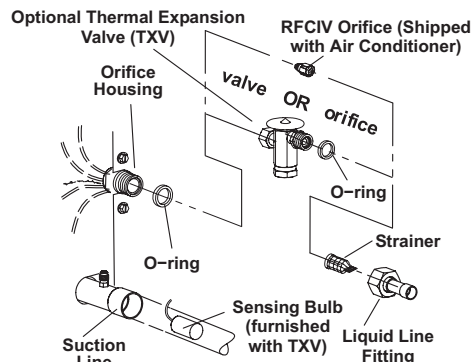

OPTIONS

Expansion Valve Kits

Expansion valve available for field installation.

See Air Conditioners and Heat Pump Outdoor Units bulletins for expansion valve/check expansion valve kit selection.

SPECIFICATIONS

1.5 TO 2.5 TON

General Data		Model No.	CH33 -18A-2F	CH33 19A-2F	CH33 -24/30A-2F	CH33 -25A-2F	CH33 -25B-2F	CH33 -31A-2F	CH33 -31B-2F
Nominal size - Tons			1.5	1.5	2/2.5	2	2	2.5	2.5
Line connections in.	Suction / vapor o.d. - sweat		3/4	3/4	3/4	3/4	3/4	3/4	3/4
	Liquid o.d. - sweat		3/8	3/8	3/8	3/8	3/8	3/8	3/8
	Condensate drain (fpt)		3/4	3/4	3/4	3/4	3/4	3/4	3/4
RFCIV metering device orifice size			0.053	0.053	0.062	0.062	0.062	0.071	0.071
Indoor Coil	Net face area sq. ft.		1.75	3.5	3.5	3.5	3.5	4.33	4.67
	Tube diameter - in.		3/8	3/8	3/8	3/8	3/8	3/8	3/8
	Number of rows		2	2	2	3	2	3	3
	Fins per inch		18	19	18	14	19	16	14
Matching Lennox Furnace - Cabinet Width Designation			A	A	A	A	B	A	B
¹ Coil & Furnace Cabinet Height - in.			14-1/2	14-1/2	14-1/2	14-1/2	17-1/2	14-1/2	17-1/2
Shipping Data - lbs.			20	37	42	38	38	40	45

SPECIFICATIONS

3 TO 3.5 TON

General Data		Model No.	CH33 -36A-2F	CH33 -36B-2F	CH33 -36C-2F	CH33 -42B-2F	CH33 -43B-2F	CH33 -43C-2F
Nominal size - Tons			3	3	3	3.5	3.5	3.5
Line connections in.	Suction / vapor o.d. - sweat		3/4	3/4	3/4	7/8	7/8	7/8
	Liquid o.d. - sweat		3/8	3/8	3/8	3/8	3/8	3/8
	Condensate drain (fpt)		3/4	3/4	3/4	3/4	3/4	3/4
RFCIV metering device orifice size			0.076	0.076	0.076	0.082	0.082	0.082
Indoor Coil	Net face area sq. ft.		3.5	4.67	5.83	4.67	5.78	5.83
	Tube diameter - in.		3/8	3/8	3/8	3/8	3/8	3/8
	Number of rows		3	2	2	3	4	3
	Fins per inch		12	18	18	12	12	13
Matching Lennox Furnace - Cabinet Width Designation			A	B	C	B	B	C
¹ Coil & Furnace Cabinet Height - in.			14-1/2	17-1/2	21	17-1/2	17-1/2	21
Shipping Data - lbs.			54	44	48	60	76	82

SPECIFICATIONS

3.5 TO 5 TON

General Data		Model No.	CH33	CH33	CH33	CH33	CH33	CH33
			-44/48B-2F	-48C-2F	-49C-2F	-50/60C-2F	-60D-2F	-62D-2F
		Nominal size - Tons	3.5/4	4	4	4/5	5	5
Line connections in.	Suction / vapor o.d. - sweat		7/8	7/8	7/8	7/8	7/8	7/8
	Liquid o.d. - sweat		3/8	3/8	3/8	3/8	3/8	3/8
	Condensate drain (fpt)		3/4	3/4	3/4	3/4	3/4	3/4
RFCIV metering device orifice size			0.082	0.091	0.091	0.091	0.099	0.099
Indoor Coil	Net face area sq. ft.		5.78	5.83	7.22	7.22	6.42	7.94
	Tube diameter - in.		3/8	3/8	3/8	3/8	3/8	3/8
	Number of rows		3	3	3	3	3	3
	Fins per inch		12	12	13	12	12	12
Matching Lennox Furnace - Cabinet Width Designation			B	C	C	C	D	D
¹ Coil & Furnace Cabinet Height - in.			17-1/2	21	21	21	24-1/2	24-1/2
Shipping Data - lbs.			72	76	86	86	87	97

AIR RESISTANCE

Air Volume cfm	Total Air Resistance - in. w.g.															
	CH33-18A		CH33-19A		CH33-24/30A		CH33-25A		CH33-25B		CH33-31A		CH33-31B		CH33-36A	
	Dry Coil	Wet Coil	Dry Coil	Wet Coil	Dry Coil	Wet Coil	Dry Coil	Wet Coil	Dry Coil	Wet Coil	Dry Coil	Wet Coil	Dry Coil	Wet Coil	Dry Coil	Wet Coil
200	0.04	0.05	0.02	0.02	---	---	---	---	---	---	---	---	---	---	---	---
400	0.09	0.14	0.05	0.06	0.05	0.08	0.04	0.05	0.03	0.04	0.04	0.05	0.02	0.02	---	---
600	0.16	0.27	0.09	0.11	0.09	0.12	0.09	0.11	0.05	0.07	0.09	0.10	0.05	0.06	---	---
800	0.25	0.39	0.15	0.17	0.14	0.20	0.15	0.19	0.09	0.11	0.15	0.17	0.09	0.11	0.15	0.18
1000	0.37	0.53	0.22	0.25	0.21	0.29	0.23	0.29	0.15	0.17	0.24	0.27	0.14	0.16	0.22	0.27
1200	---	---	---	---	0.28	0.38	0.32	0.40	0.21	0.23	0.34	0.38	0.19	0.23	0.30	0.39
1400	---	---	---	---	0.37	0.48	0.43	0.50	0.28	0.30	0.45	0.51	0.26	0.30	0.41	0.48
1600	---	---	---	---	---	---	---	---	---	---	---	---	---	---	0.53	0.63
1800	---	---	---	---	---	---	---	---	---	---	---	---	---	---	---	---

Air Volume cfm	Total Air Resistance - in. w.g.															
	CH33-36B		CH33-36C		CH33-43B		CH33-43C		CH33-42B CH33-44/48B		CH33-48C CH33-50/60C		CH33-49C		CH33-60D CH33-62D	
	Dry Coil	Wet Coil	Dry Coil	Wet Coil	Dry Coil	Wet Coil	Dry Coil	Wet Coil	Dry Coil	Wet Coil	Dry Coil	Wet Coil	Dry Coil	Wet Coil	Dry Coil	Wet Coil
800	0.08	0.10	0.06	0.08	0.10	0.10	0.06	0.06	---	---	---	---	---	---	---	---
1000	0.11	0.16	0.10	0.13	0.14	0.18	0.09	0.10	0.14	0.16	---	---	---	---	---	---
1200	0.16	0.21	0.15	0.18	0.20	0.25	0.15	0.16	0.19	0.23	0.16	0.19	0.15	0.16	---	---
1400	0.21	0.27	0.19	0.23	0.26	0.31	0.18	0.21	0.25	0.29	0.21	0.26	0.20	0.23	0.12	0.16
1600	0.27	0.35	0.24	0.31	0.34	0.36	0.26	0.28	0.30	0.38	0.27	0.30	0.25	0.29	0.16	0.20
1800	---	---	---	---	0.42	0.47	0.31	0.38	0.38	0.42	0.33	0.39	0.31	0.36	0.20	0.24
2000	---	---	---	---	---	---	---	---	---	---	0.39	0.49	0.40	0.44	0.24	0.30
2200	---	---	---	---	---	---	---	---	---	---	---	---	0.48	0.54	0.29	0.36
2400	---	---	---	---	---	---	---	---	---	---	---	---	---	---	0.34	0.42

DIMENSIONS - INCHES (MM)

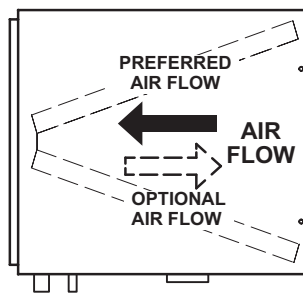

TOP VIEW

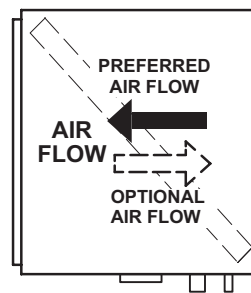

TOP VIEW
CH33-18A

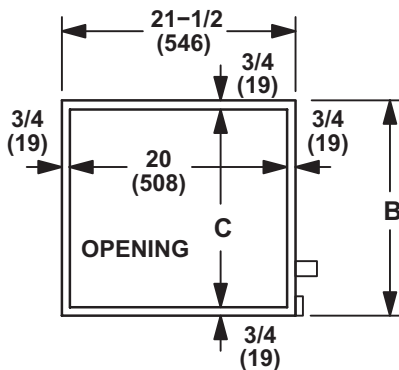

END VIEW

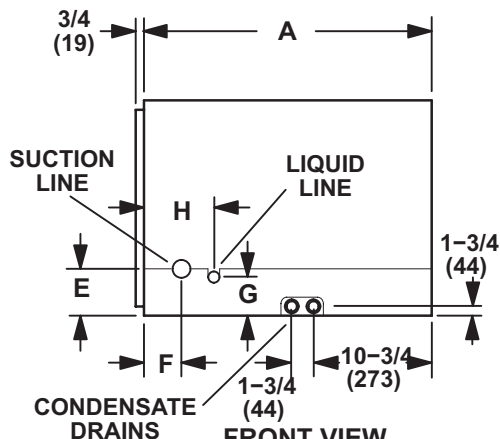

FRONT VIEW

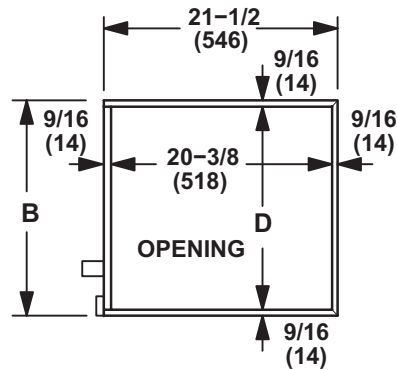

END VIEW

Model No.	A		B		C		D		E		F		G		H	
	in.	mm	in.	mm	in.	mm	in.	mm	in.	mm	in.	mm	in.	mm	in.	mm
CH33-18A-2F	21-1/2	546	14-1/2	368	13	330	13-3/8	340	3-3/4	95	3-1/4	83	2-3/4	70	1-3/4	44
CH33-19A-2F	26-1/2	673	14-1/2	368	13	330	13-3/8	340	4	102	2-1/8	54	3	76	4-7/8	124
CH33-24/30A-2F	26-1/2	673	14-1/2	368	13	330	13-3/8	340	4	102	2-1/8	54	3	76	4-7/8	124
CH33-25A-2F	26-1/2	673	14-1/2	368	13	330	13-3/8	340	4	102	2-1/8	54	3	76	4-7/8	124
CH33-25B-2F	26-1/2	673	17-1/2	444	16	406	16-3/8	416	4	102	2-1/8	54	3	76	4-7/8	124
CH33-31A-2F	31-1/2	800	14-1/2	368	13	330	13-3/8	340	4	102	2-1/8	54	3	76	4-7/8	124
CH33-31B-2F	26-1/2	673	17-1/2	444	16	406	16-3/8	416	4	102	2-1/8	54	3	76	4-7/8	124
CH33-36A-2F	26-1/2	673	14-1/2	368	13	330	13-3/8	340	4	102	2-1/8	54	3	76	4-7/8	124
CH33-36B-2F	26-1/2	673	17-1/2	444	16	406	16-3/8	416	4	102	2-1/8	54	3	76	4-7/8	124
CH33-36C-2F	26-1/2	673	21	533	19-1/2	495	19-7/8	505	4	102	2-1/8	54	3	76	4-7/8	124
CH33-42B-2F	26-1/2	673	17-1/2	444	16	406	16-3/8	416	4	102	2-1/8	54	3	76	4-7/8	124
CH33-43B-2F	31-1/2	800	17-1/2	444	16	406	16-3/8	416	4	102	2-1/8	54	3	76	4-7/8	124
CH33-43C-2F	26-1/2	673	21	533	19-1/2	495	19-7/8	505	4	102	2-1/8	54	3	76	4-7/8	124
CH33-44/48B-2F	31-1/2	800	17-1/2	444	16	406	16-3/8	416	4	102	2-1/8	54	3	76	4-7/8	124
CH33-48C-2F	26-1/2	673	21	533	19-1/2	495	19-7/8	505	4	102	2-1/8	54	3	76	4-7/8	124
CH33-49C-2F	31-1/2	800	21	533	19-1/2	495	19-7/8	505	4	102	2-1/8	54	3	76	4-7/8	124
CH33-50/60C-2F	31-1/2	800	21	533	19-1/2	495	19-7/8	505	4	102	2-1/8	54	3	76	4-7/8	124
CH33-60D-2F	26-1/2	673	24-1/2	622	23	584	23-3/8	594	4	102	2-1/8	54	3	76	4-7/8	124
CH33-62D-2F	31-1/2	800	24-1/2	622	23	584	23-3/8	594	4	102	2-1/8	54	3	76	4-7/8	124



Visit us at www.lennox.com

For the latest technical information, www.lennox.com

Contact us at 1-800-4-LENNOX

NOTE - Due to Lennox' ongoing commitment to quality, Specifications, Ratings and Dimensions subject to change without notice and without incurring liability. Improper installation, adjustment, alteration, service or maintenance can cause property damage or personal injury. Installation and service must be performed by a qualified installer and servicing agency.

©2010 Lennox Industries, Inc.