



ENGINEERING DATA

Bulletin No. 210485
September 2010
October 2009



MODEL NUMBER IDENTIFICATION

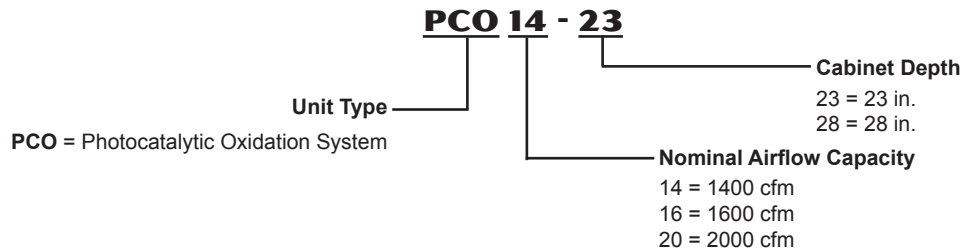

FEATURES

CONTENTS

Air Resistance.....	4
Applications	2
Dimensions	5
Features.....	1
Match-Ups - PCO With Furnace / Air Handler	6
Minimum Filter Efficiency.....	4
Model Number Identification	1
Optional Accessories	4
Specifications.....	4

APPROVALS

ETL safety listing report 3061144A. Conforms to UL STD 1598. Certified to CSA STD C22.2 no. 250.0.

WARRANTY

All covered components have a limited warranty for five years in residential applications, one year in non-residential applications.

Lamps, pleated filters and PCO metal inserts are routine maintenance items and are not covered under the warranty.

Refer to the Lennox Limited Warranty certificate included with the unit for additional details.

OPERATION

Return air first passes through the MERV 16 Precision Pleat™ filter. The filter removes more than 95% of the particles and bioaerosols (dander, pollen, bacteria, molds, spores, etc.) as they flow through the PCO.

The filtered air then passes through the UVA lamps and PCO metal insert. The UVA lamps activate the catalyst on the PCO metal insert that captures and destroys odors and chemical vapors as they flow through the system.

The adsorbed pollutants (accumulated gases, liquids, or solids) on the surface of the catalyst are oxidized to carbon dioxide and water.

Rather than just absorbing gaseous pollutants (as in carbon systems), PCO provides a reduction of absolute toxicity. Contaminants are destroyed rather than transferred.

The PCO metal insert is self-cleaning with respect to the organic material adsorbed on the catalyst surface.

No toxic chemicals are used in the PCO.

FEATURES

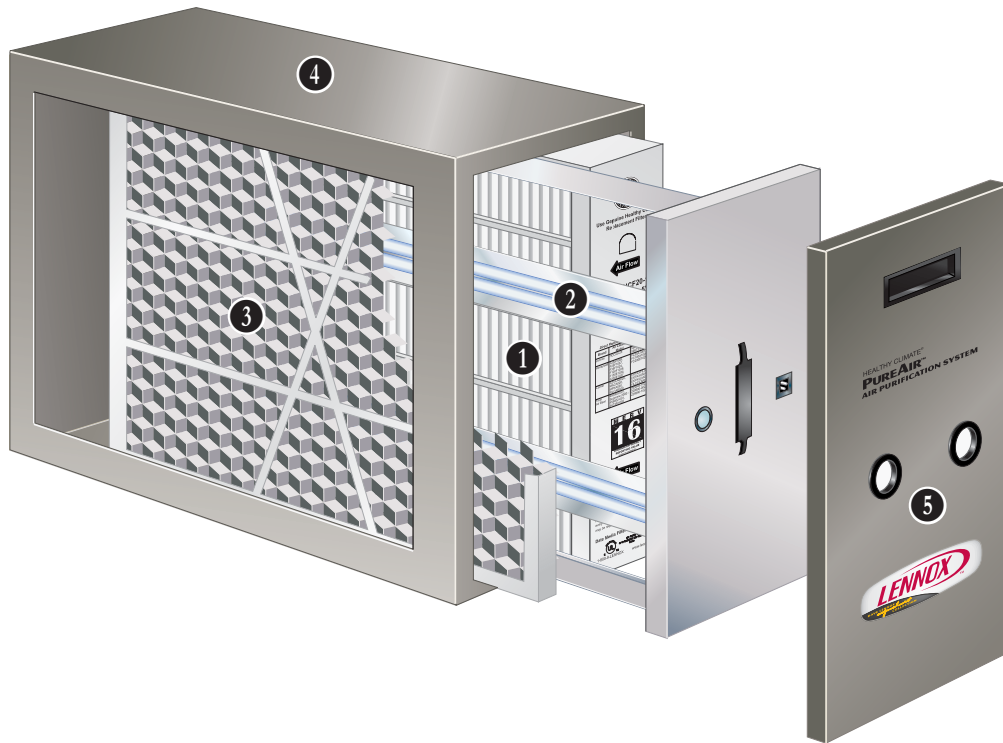

APPLICATIONS

The PureAir™ Air Purification System combines multiple air purification technologies into a single, state-of-the-art, air purifier.

The system's primary function is to improve the indoor air quality by:

- Filtration - The MERV 16 Precision Pleat media filter captures more than 95% of particles 0.3 microns and larger and more than 90% of particles 0.01 microns and larger.
- Photocatalytic Oxidation - The UVA lamps activate the photocatalyst on the metal insert that captures and destroys odors and chemical vapors as they flow through the PCO.

The system reduces the toxicity of the treated air stream.

The PCO is a multi-position unit that can be installed in the return air side of all types of HVAC whole-house systems.

The unit easily adapts to upflow, downflow or horizontal unit applications.

No ozone is produced by the PCO; in fact, ozone is reduced by the PCO.

Only requires annual maintenance.

INSTALLATION CONSIDERATIONS

The PCO must be installed in the return air duct upstream of the supply air blower. Allow a 30 in. service clearance in front of the access door. The control box, pleated filter and metal insert must be removable.

The PCO should be installed in a horizontal position with the access panel facing to the front or rear. If the PCO must be installed in a vertical position with the access panel pointing upward and the lamps suspended vertically from the sockets, retaining clips are required to lock the lamps in the sockets. Contact the Lennox Technical Support Department for additional information.

The PCO must be connected to either a 120V or 230V power receptacle. If 230V power supply is used, an optional 230V power cord must be ordered separately. See Optional Accessories table.

Unit must be powered continuously (lamps are always on) for destruction of contaminants adsorbed on the catalyst surface and for extended lamp life.

It is recommended that the air handler be set to run continuously, except during periods of high humidity (more than 50%).

If used in conjunction with a UV germicidal light, the following must be adhered to:

- When a germicidal light is used with the PCO in direct line of sight, maintain a minimum distance of 6 ft. from the PCO.
- If duct system has a 90° bend or turn in the duct between the PCO and germicidal light, a minimum distance of 3 ft. from the PCO should be maintained.

Please refer to the Installation Instructions for additional information.

FEATURES

COMPONENTS

1 MERV 16 Precision Pleat™ Media Air Filter (1)

Disposable pleated MERV 16 filter (Minimum Efficiency Reporting Value based on ASHRAE 52.2).

MERV (Minimum Efficiency Reporting Value) is a rating by ASHRAE that measures the removal of airborne contaminants.

The MERV rating of a filter describes the size of the holes in the filter that allow air to pass through. The higher the MERV rating, the smaller the holes in the filter providing enhanced filtration. The dirtier the filter, the better the filtration, however, the filters need to be replaced annually to prevent excess pressure drop and for maximum efficiency. More frequent filter changes may be required in situations with high dust or dirt loads. Particles and bioaerosols are captured on the filter.

Recommended annual replacement.

2 UVA Lamps (2)

55 watt florescent, low power consumption, UVA output.

Recommended annual replacement.

3 PCO Metal Insert (1)

Titanium dioxide coated PCO metal insert.

Single piece honeycomb design.

Insert is vacuum packaged.

Recommended annual replacement.

4 CABINET

Pre-painted steel cabinet.

Multi-position.

PCO14-23 cabinet is sized for most Lennox air handler applications.

PCO16-28 and PCO20-28 cabinets are sized for most Lennox gas furnace applications.

See dimension drawing.

5 Front panel is removable for service access.

Air flow direction may be reversed by rotating the unit top for bottom and re-positioning the front panel to the upright position.

View port on front panel for verifying UVA lamp operation.

Three-prong, detachable 6-foot power cord for plug-in to 120V electrical connection. Optional power cord for 230V operation is available and must be ordered extra.

SAFETY FEATURES

Power cord must be completely removed from the front of the unit before the cover can be removed.

MAINTENANCE SUPPLIES - MUST BE ORDERED EXTRA

Annual Maintenance Kit

A maintenance kit is available for the PCO14-23, PCO16-28 and PCO-20-28.

Each kit consists of:

- MERV 16 Precision Pleat Media Air Filter (1)
- Replacement UVA Lamps (2)
- Replacement PCO Metal Insert (1)

MERV 16 Precision Pleat™ Media Air Filter

Recommended annual replacement of the filter.

OPTIONAL ACCESSORIES - MUST BE ORDERED EXTRA

Power Cord For 230 Volt Operation

Six foot power cord with NEMA 620P male plug on one end and IEC 320 receptacle on other end allows 230 volt operation without any additional modifications.

Hardwiring Kit

For installation where local or national codes require a permanent (hard-wired) electrical connection.

Kit consists of new front access panel and connector cover. Kit replaces existing access panel and three-prong power cord.

Connection cover has 7/8 in. electrical knockouts on three sides for easy electrical connection using flexible conduit in any direction.

ETL approved.

SPECIFICATIONS

	Model No.	PCO14-23	PCO16-28	PCO20-28
Nominal airflow capacity - cfm		1400	1600	2000
Pressure drop (new unit) - in. w.g.		0.28	0.30	0.32
Pressure drop (end of recommended life) - in. w.g.		0.42	0.42	0.42
Ethanol destruction rate - mg/min. (single pass rated flow destruction rate @ 500 µg/m ³ ethanol)		2.5	3	4
Number of lamps		2	2	2
Filter size - in.	Nominal	20 x 21 x 5	16 x 26 x 5	20 x 26 x 5
	Actual	20 x 20-5/8 x 4-3/8	16-3/8 x 25-1/2 x 4-3/8	20 x 25-1/2 x 4-3/8
Filter life		Up to 12 months	Up to 12 months	Up to 12 months
Shipping Weight - lbs.		34	36	39
Electrical Data		120V or ¹ 230V - 1 phase - 60 hz		
Power Consumption	120 Volt	144 watts	144 watts	144 watts
	¹ 230 Volt	150 watts	150 watts	150 watts

ANNUAL MAINTENANCE KIT - MUST BE ORDERED EXTRA

Kit contains	Catalog Number	X8797	X8796	X8795
MERV 16 Pleated Filter (1)	Size - H x D x W - in.	20 x 21 x 5	16 x 26 x 5	20 x 26 x 5
UVA Lamps (2)	Number of lamps furnished	2	2	2
PCO Metal Insert (1)	Size - H x D x W - in.	20 x 21 x 1	16 x 26 x 1	20 x 26 x 1

MAINTENANCE SUPPLIES - MUST BE ORDERED EXTRA

MERV 16 Pleated Filter (1)	Catalog Number	X8790	X8789	X8788
----------------------------	----------------	-------	-------	-------

OPTIONAL ACCESSORIES - MUST BE ORDERED EXTRA

Power Cord for 230V Operation		91X44	91X44	91X44
Hardwiring Kit		Y0627	Y0628	Y0627

¹ Optional 230V power cord is required and must be ordered extra.

AIR RESISTANCE

Air Volume cfm	PCO14-23 in. w.g.	PCO16-28 in. w.g.	PCO20-28 in. w.g.
800	0.12	0.11	0.09
1000	0.17	0.15	0.12
1200	0.22	0.20	0.16
1400	0.28	0.25	0.19
1600	Not Recommended	0.30	0.23
1800	Not Recommended	Not Recommended	0.28
2000	Not Recommended	Not Recommended	0.32

MINIMUM FILTER EFFICIENCY

MERV Rating	¹ Filter Efficiency (percentage)		
	E1 (0.3 to 1.0 microns)	E2 (1.0 to 3.0 microns)	E3 (3.0 to 10.0 microns)
MERV 16	95%	99%	99%

¹ Values are based on lab tests conducted with conditions included in ASHRAE Standard 52.2.

DIMENSIONS - INCHES (MM)

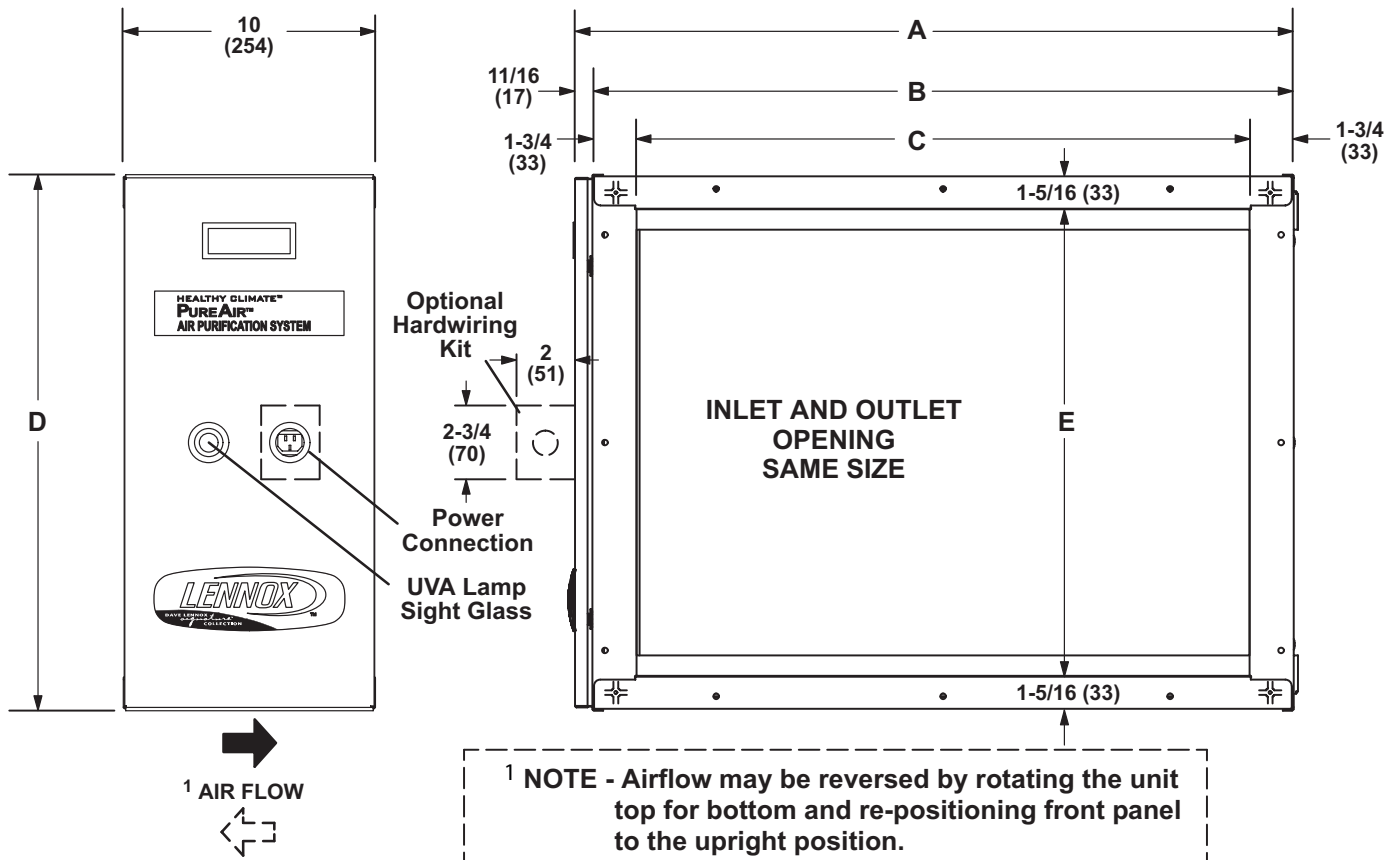

Model No.	A		B		C		D		E	
	inches	mm	inches	mm	inches	mm	inches	mm	inches	mm
PCO14-23	23	584	22-5/16	567	18-13/16	478	21-1/8	537	18-1/2	470
PCO16-28	28-1/2	724	27-13/16	706	24-5/16	618	17-1/4	438	14-5/8	371
PCO20-28	28-1/2	724	27-13/16	706	24-5/16	618	21-1/8	537	18-1/2	470

MATCH-UPS - PCO WITH FURNACE / AIR HANDLER

ALSO SEE ILLUSTRATIONS ON NEXT PAGE FOR ADDITIONAL DETAILS

Furnaces	Filter Cabinet			Comment
	PCO14-23	PCO16-28	PCO20-28	
"A" Width Furnace with Side Return Air		•		No duct transition required.
"A" Width Furnace with Bottom Return Air		•		28-1/2" x 3" side seal strip or duct transition needed.
"B" Width Furnace with Side Return Air		•		No duct transition required.
"B" Width Furnace with Bottom Return Air		•		No duct transition required.
"C" Width Furnace with Side Return Air (up to 4 ton)		•	•	No duct transition required, for high system static application use PCO20-28.
"C" Width Furnace with Side Return Air (5 ton)			•	Option 1 - No duct transition required, use Return Air Base (98M58). Option 2 - Overcut top edge of side return opening by 1 in. to make opening 15 in. x 23 in. (H x W).
"C" Width Furnace with Bottom Return Air			•	No duct transition required.
"D" Width Furnace with Side Return Air			•	Option 1 - No duct transition required, use Return Air Base (98M59). Option 2 - Overcut top edge of side return opening by 1 in. to make opening 15 in. x 23 in. (H x W).
"D" Width Furnace with Bottom Return Air			•	28-1/2" x 3 1/2" side seal strip or duct transition needed.
Air Handlers	PCO14-23	PCO16-28	PCO20-28	Comment
Air Handler (W x D) - 16-1/4 x 20-5/8" CBX32MV-018/024 CBX32M-018/024	•	•		Duct transition required.
Air Handler (W x D) - 21-1/4 x 20-5/8" CBX27UH-018 CBX27UH-024 CBX32MV-024-030 CBX32M-030	•			No duct transition required.
Air Handler (W x D) - 21-1/4 x 22-5/8" CBX27UH-030 CBX27UH-036 CBX32MV-036 CBX32M-036-042 CBX40UHV-024-030-036	•			No duct transition required.
Air Handler (W x D) - 21-1/4 x 24-5/8" CBX27UH-042 CBX27UH-048 CBX27UH-060 CBX32MV-048-060 CBX32M-048-060			•	21" x 3" side seal strip or duct transition needed.
Air Handler (W x D) - 21-1/4 x 25-5/8" CBX40UHV-042-048-060			•	21" x 3" side seal strip or duct transition needed.
Air Handler (W x D) - 21-1/4 x 26-5/8" CBX32MV-068			•	No duct transition required.
Air Handler (W x D) - 18-1/2 x 22" CBX26UH-018-024	•			22" x 2" side seal strip or duct transition needed.
Air Handler (W x D) - 21-1/4 x 22" CBX26UH-030-036	•			No duct transition required.
Air Handler (W x D) - 21-1/4 x 26" CBX26UH-042-048-060			•	No duct transition required.
Hot Water Air Handlers	PCO14-23	PCO16-28	PCO20-28	Comment
"B" Width CBWMV with Side Return Air		•		No duct transition required.
"B" Width CBWMV with Bottom Return Air		•		No duct transition required.
"C" Width CBWMV with Side Return Air (up to 4 ton)		•	•	No duct transition required, for high system static application use PCO20-28.
"C" Width CBWMV with Side Return Air (5 ton)			•	Option 1 - No duct transition required, use Return Air Base (98M58). Option 2 - Overcut top edge of side return opening by 1 in. to make opening 15 in. x 23 in. (H x W).
"C" Width CBWMV with Bottom Return Air			•	No duct transition required.

MATCH-UPS –PCO WITH FURNACE / AIR HANDLER

**UPFLOW FURNACE/AIR HANDLER
(Bottom Return Air)**

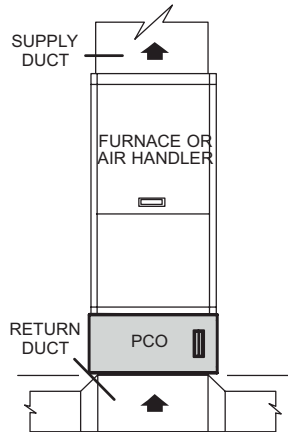

**UPFLOW FURNACE
(Side Return Air – up to 4 ton)**

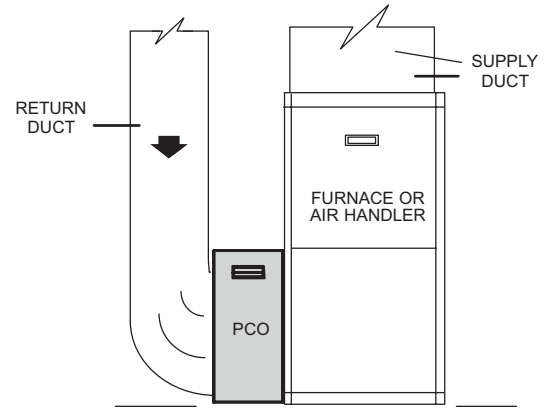

DOWNFLOW FURNACE/AIR HANDLER

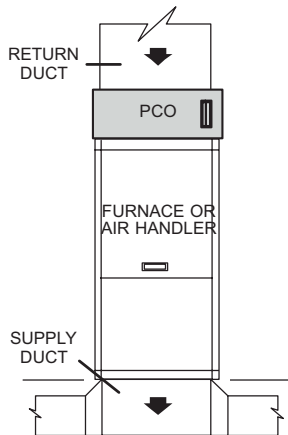

**UPFLOW FURNACE
(Option 1 – Side Return Air – 5 ton)
(With Optional RAB Return Air Base)**

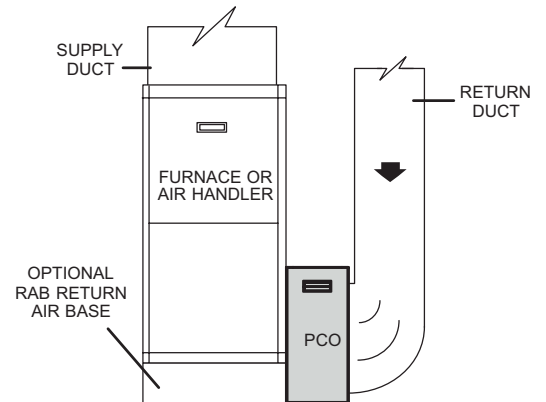

HORIZONTAL FURNACE/AIR HANDLER

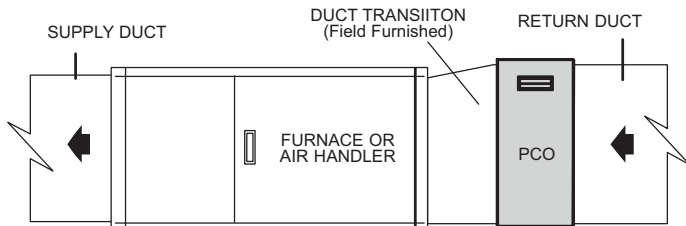

**UPFLOW FURNACE
(Option 2 – Side Return Air – 5 ton)
(Modified Return Air Opening)**

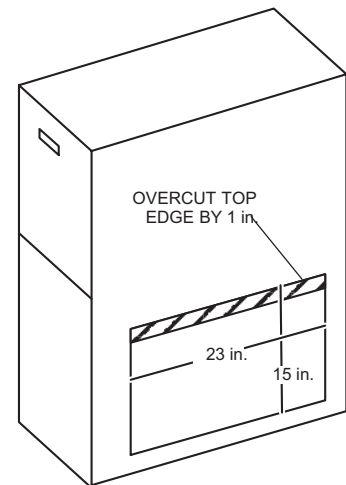

REVISIONS

Sections	Description of Change
No changes	New format publishing software.



Visit us at www.lennox.com

For the latest technical information, www.lennox.com/technical

Contact us at 1-800-4-LENNOX

NOTE - Due to Lennox' ongoing commitment to quality, Specifications, Ratings and Dimensions subject to change without notice and without incurring liability. Improper installation, adjustment, alteration, service or maintenance can cause property damage or personal injury. Installation and service must be performed by a qualified installer and servicing agency.

©2010 Lennox Industries, Inc.